



**WJR**



**22B-F8197-E0**

For more details and discussions  
logon to [www.yamahar125.com](http://www.yamahar125.com)

EAS20060

**WR125R/WR125X  
SERVICE MANUAL  
© by MBK Industrie  
All rights reserved.  
Any reproduction or unauthorized use  
without the written permission of  
MBK Industrie  
is expressly prohibited.**



# YamahaR125.COM

---

EAS20071

## IMPORTANT

This manual was produced by MBK Industrie primarily for use by Yamaha dealers and their qualified mechanics. It is not possible to include all the knowledge of a mechanic in one manual. Therefore, anyone who uses this book to perform maintenance and repairs on Yamaha vehicles should have a basic understanding of mechanics and the techniques to repair these types of vehicles. Repair and maintenance work attempted by anyone without this knowledge is likely to render the vehicle unsafe and unfit for use.

Yamaha Motor Company, Ltd. is continually striving to improve all of its models. Modifications and significant changes in specifications or procedures will be forwarded to all authorized Yamaha dealers and will appear in future editions of this manual where applicable.

### TIP

---





Designs and specifications are subject to change without notice.

---

EAS20081

## IMPORTANT MANUAL INFORMATION

Particularly important information is distinguished in this manual by the following notations.

	<b>This is the safety alert symbol. It is used to alert you to potential personal injury hazards. Obey all safety messages that follow this symbol to avoid possible injury or death.</b>
	<b>A WARNING indicates a hazardous situation which, if not avoided, could result in death or serious injury.</b>
	<b>A NOTICE indicates special precautions that must be taken to avoid damage to the vehicle or other property.</b>
	<b>A TIP provides key information to make procedures easier or clearer.</b>

# YamahaR125.COM

EAS20090

## HOW TO USE THIS MANUAL

This manual is intended as a handy, easy-to-read reference book for the mechanic. Comprehensive explanations of all installation, removal, disassembly, assembly, repair and check procedures are laid out with the individual steps in sequential order.

- The manual is divided into chapters and each chapter is divided into sections. The current section title “1” is shown at the top of each page.
- Sub-section titles “2” appear in smaller print than the section title.
- To help identify parts and clarify procedure steps, there are exploded diagrams “3” at the start of each removal and disassembly section.
- Numbers “4” are given in the order of the jobs in the exploded diagram. A number indicates a disassembly step.
- Symbols “5” indicate parts to be lubricated or replaced.
- Refer to “SYMBOLS”.
- A job instruction chart “6” accompanies the exploded diagram, providing the order of jobs, names of parts, notes in jobs, etc.
- Jobs “7” requiring more information (such as special tools and technical data) are described sequentially.

**1**  
CLUTCH

**REMOVING THE CLUTCH COVER**

**3** →

**4** →

**5** →

**6** →

Order	Job/Parts to remove	Qty	Remarks
	Engine oil		Drain. Refer to "CHANGING THE ENGINE OIL" on page 3-10.
1	Clutch cable	1	Disconnect.
2	Oil filter element cover	1	
3	Oil filter element	1	
4	Clutch cover	1	
5	Clutch cover gasket	1	
6	Dowel pin	2	
7	Oil seal	1	For installation, reverse the removal procedure.

5-38

**2**  
CLUTCH

**REMOVING THE CLUTCH**

1. Remove:  
• Clutch cover

**TIP**  
Loosen each bolt 1/4 of a turn at a time, in stages and in a crisscross pattern. After all of the bolts are fully loosened, remove them.

2. Straighten the lock washer tab.  
3. Loosen:  
• Clutch boss nut "1"

**TIP**  
While holding the clutch boss "2" with the universal clutch holder "3", loosen the clutch boss nut.

**Universal clutch holder**  
90890-04086  
YM-91042

**TIP**  
Measure the friction plate at four places.

Friction plate 1 thickness	2.90-3.10 mm (0.114-0.122 in)
Wear limit	2.80 mm (0.110 in)
Friction plate 2 thickness	2.90-3.10 mm (0.114-0.122 in)
Wear limit	2.80 mm (0.1102 in)
Friction plate 3 thickness	2.90-3.10 mm (0.114-0.122 in)
Wear limit	2.80 mm (0.1102 in)

**CHECKING THE FRICTION PLATES**  
The following procedure applies to all of the friction plates.

1. Check:  
• Friction plate  
Damage/wear → Replace the friction plates as a set.

2. Measure:  
• Friction plate thickness  
Out of specification → Replace the friction plates as a set.

A. Friction plate 1  
B. Friction plate 2  
C. Friction plate 3  
a. Green paint mark

**7**

5-42

# YamahaR125.COM

EAS20100

## SYMBOLS

The following symbols are used in this manual for easier understanding.

### TIP

The following symbols are not relevant to every vehicle.

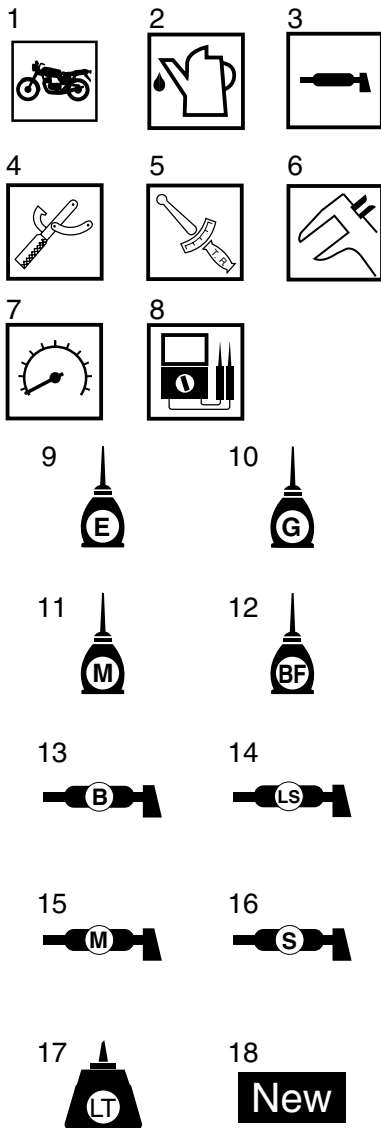

1. Serviceable with engine mounted
2. Filling fluid
3. Lubricant
4. Special tool
5. Tightening torque
6. Wear limit, clearance
7. Engine speed
8. Electrical data
9. Engine oil
10. Gear oil
11. Molybdenum disulfide oil
12. Brake fluid
13. Wheel bearing grease
14. Lithium-soap-based grease
15. Molybdenum disulfide grease
16. Silicone grease
17. Locking agent (LOCTITE®)
18. Replace the part with a new one.

YamahaR125.COM

---

# TABLE OF CONTENTS

<b>GENERAL INFORMATION</b>	<b>1</b>
<b>SPECIFICATIONS</b>	<b>2</b>
<b>PERIODIC CHECKS AND ADJUSTMENTS</b>	<b>3</b>
<b>CHASSIS</b>	<b>4</b>
<b>ENGINE</b>	<b>5</b>
<b>COOLING SYSTEM</b>	<b>6</b>
<b>FUEL SYSTEM</b>	<b>7</b>
<b>ELECTRICAL SYSTEM</b>	<b>8</b>
<b>TROUBLESHOOTING</b>	<b>9</b>

YamahaR125.COM

---

## GENERAL INFORMATION

<b>IDENTIFICATION</b> .....	1-1
VEHICLE IDENTIFICATION NUMBER .....	1-1
MODEL LABEL.....	1-1
<b>FEATURES</b> .....	1-2
OUTLINE OF THE FI SYSTEM.....	1-2
FI SYSTEM.....	1-3
INSTRUMENT FUNCTIONS .....	1-4
<b>IMPORTANT INFORMATION</b> .....	1-6
PREPARATION FOR REMOVAL AND DISASSEMBLY.....	1-6
REPLACEMENT PARTS.....	1-6
GASKETS, OIL SEALS AND O-RINGS .....	1-6
LOCK WASHERS/PLATES AND COTTER PINS .....	1-6
BEARINGS AND OIL SEALS .....	1-7
CIRCLIPS .....	1-7
<b>CHECKING THE CONNECTIONS</b> .....	1-8
<b>SPECIAL TOOLS</b> .....	1-9

EAS20130

## IDENTIFICATION

EAS20140

### VEHICLE IDENTIFICATION NUMBER

The vehicle identification number "1" is stamped into the right side of the steering head pipe.

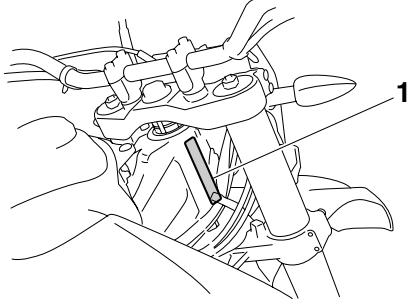

EAS20150

### MODEL LABEL

The model label "1" is affixed to the frame under the seat. This information will be needed to order spare parts.

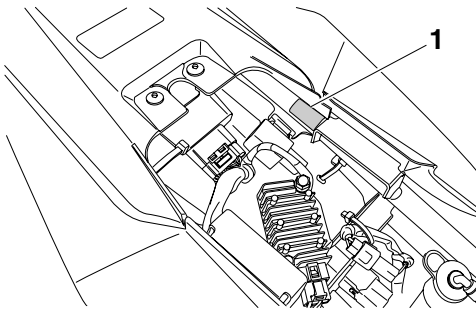



EAS20170

**FEATURES**

EAS22B1001

**OUTLINE OF THE FI SYSTEM**

The main function of a fuel supply system is to provide fuel to the combustion chamber at the optimum air-fuel ratio in accordance with the engine operating conditions and the atmospheric temperature. In the conventional carburetor system, the air-fuel ratio of the mixture that is supplied to the combustion chamber is created by the volume of the intake air and the fuel that is metered by the jet used in the respective carburetor.

Despite the same volume of intake air, the fuel volume requirement varies by the engine operating conditions, such as acceleration, deceleration, or operating under a heavy load. Carburetors that meter the fuel through the use of jets have been provided with various auxiliary devices, so that an optimum air-fuel ratio can be achieved to accommodate the constant changes in the operating conditions of the engine.

As the requirements for the engine to deliver more performance and cleaner exhaust gases increase, it becomes necessary to control the air-fuel ratio in a more precise and finely tuned manner. To accommodate this need, this model has adopted an electronically controlled fuel injection (FI) system, in place of the conventional carburetor system. This system can achieve an optimum air-fuel ratio required by the engine at all times by using a microprocessor that regulates the fuel injection volume according to the engine operating conditions detected by various sensors.

The adoption of the FI system has resulted in a highly precise fuel supply, improved engine response, better fuel economy, and reduced exhaust emissions.

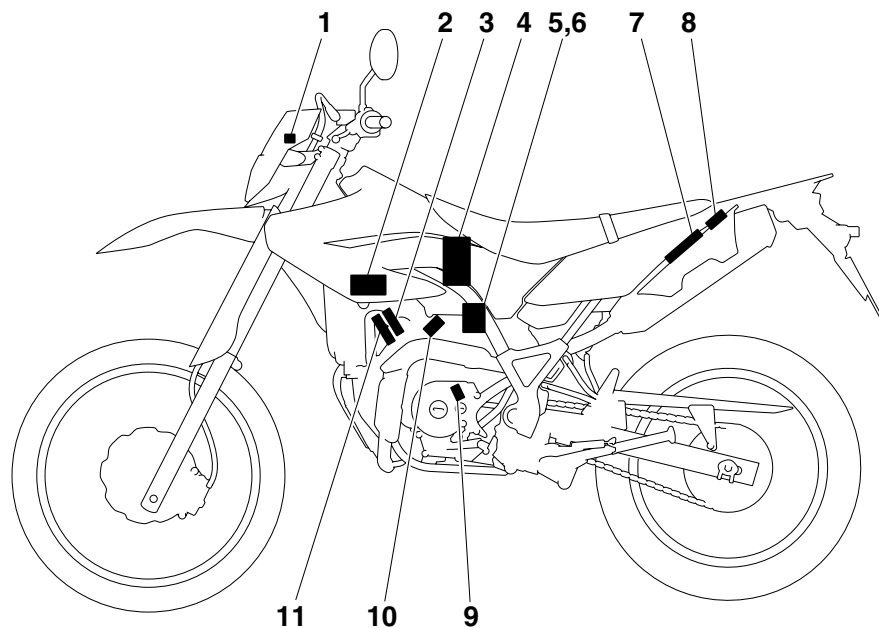

- |  |                   |
|--|-------------------|
| 1. Engine trouble warning light  | 10. Fuel injector |
| 2. Ignition coil   | 11. Spark plug    |
| 3. Coolant temperature sensor  |                   |
| 4. Fuel pump   |                   |
| 5. FID (fast idle solenoid)  |                   |
| 6. Throttle body sensor assembly (consisting of throttle position sensor, intake air pressure sensor, intake air temperature sensor) |                   |
| 7. ECU (engine control unit)   |                   |
| 8. Lean angle sensor   |                   |
| 9. Crankshaft position sensor  |                   |

EAS22B1002

## FI SYSTEM

The fuel pump delivers fuel to the fuel injector via the fuel filter. The pressure regulator maintains the fuel pressure that is applied to the fuel injector at only 250 kPa (2.50 kgf/cm<sup>2</sup>, 36.3 psi). Accordingly, when the energizing signal from the ECU energizes the fuel injector, the fuel passage opens, causing the fuel to be injected into the intake manifold only during the time the passage remains open. Therefore, the longer the length of time the fuel injector is energized (injection duration), the greater the volume of fuel that is supplied. Conversely, the shorter the length of time the fuel injector is energized (injection duration), the lesser the volume of fuel that is supplied.

The injection duration and the injection timing are controlled by the ECU. Signals that are input from the throttle position sensor, crankshaft position sensor, intake air pressure sensor, intake air temperature sensor, lean angle sensor and coolant temperature sensor enable the ECU to determine the injection duration. The injection timing is determined through the signals from the crankshaft position sensor. As a result, the volume of fuel that is required by the engine can be supplied at all times in accordance with the driving conditions.

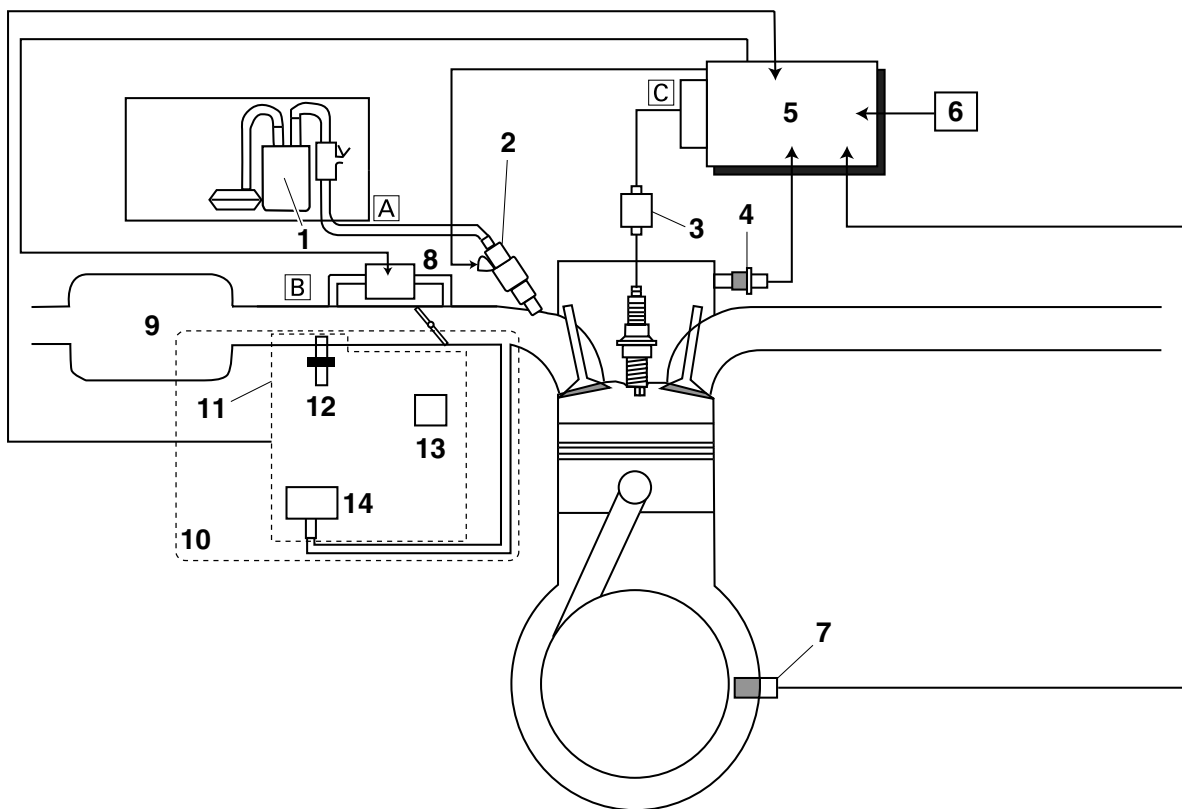

- |                               |                                   |
|-------------------------------|-----------------------------------|
| 1. Fuel pump                  | 11. Throttle body sensor assembly |
| 2. Fuel injector              | 12. Intake air temperature sensor |
| 3. Ignition coil              | 13. Throttle position sensor      |
| 4. Coolant temperature sensor | 14. Intake air pressure sensor    |
| 5. ECU (engine control unit)  |                                   |
| 6. Lean angle sensor          | A. Fuel system                    |
| 7. Crankshaft position sensor | B. Air system                     |
| 8. FID (fast idle solenoid)   | C. Control system                 |
| 9. Air filter case            |                                   |
| 10. Throttle body             |                                   |

EAS22B1038

**INSTRUMENT FUNCTIONS****Multi-function display**

EWA22B1019

**WARNING**

Be sure to stop the vehicle before making any setting changes to the multi-function display. Changing settings while riding can distract the operator and increase the risk of an accident.

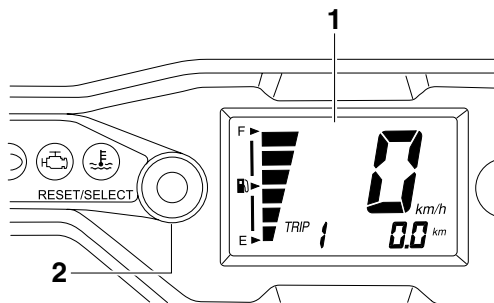

1. Multi-function display
2. "RESET/SELECT" button

The multi-function display is equipped with the following:

- a speedometer
- an odometer
- two tripmeters (which show the distance traveled since they were last set to zero)
- a fuel reserve tripmeter (which shows the distance traveled since the fuel level warning light came on)
- an oil change indicator (which flashes when the engine oil should be changed)
- a fuel meter

**TIP**

- Be sure to turn the key to "ON" before using the "RESET/SELECT" button.
- When the key is turned to "ON", all segments of the display come on for a few seconds. During this time, the multi-function display is performing a self-test.
- For the U.K. only: To switch the speedometer and odometer/tripmeter displays between kilometers and miles, press the "RESET/SELECT" button for at least eight seconds.

**Odometer and tripmeter modes**

A brief push (less than one second) on the "RESET/SELECT" button switches the display between the odometer mode "ODO" and the tripmeter modes "TRIP 1" and "TRIP 2" in the following order:

ODO → TRIP 1 → TRIP 2 → ODO

When approximately 1.6 L (0.42 US gal, 0.35 Imp.gal) of fuel remains in the fuel tank, the odometer display will automatically change to the fuel reserve tripmeter mode "F-TRIP" and start counting the distance traveled from that point, and the last segment of the fuel meter will start flashing. In that case, pushing the "RESET/SELECT" button switches the display between the various tripmeter and odometer modes in the following order:

F-TRIP → TRIP 1 → TRIP 2 → ODO → F-TRIP

To reset a tripmeter, select it by pushing the "RESET/SELECT" button briefly (less than one second), and then push the button again for at least three seconds. If you do not reset the fuel reserve tripmeter manually, it will reset itself automatically and the display will return to the prior mode after refueling and traveling 5 km (3 mi).

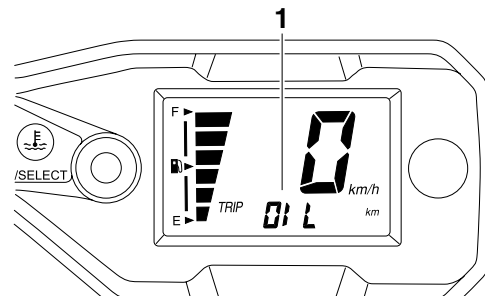
**Oil change indicator**

1. Oil change indicator "OIL"

This indicator flashes at the initial 1000km (600mi), then at 3000km (1800mi) and every 3000km (1800 mi) thereafter to indicate that the engine oil should be changed.

After changing the engine oil, reset the oil change indicator.

**TIP**

The oil change indicator can only be reset when "OIL" flashes in the multi-function display.

To reset the oil change indicator, select it by pushing the "RESET/SELECT" button briefly (less than one second), and then pushing the button again for at least five seconds. When the

oil change indicator stops flashing and stays on, release the “RESET/SELECT” button within three seconds; the indicator will go off.

**TIP**

If the oil change indicator still flashes after the reset procedure has been completed, repeat the reset procedure completely.

---

### Fuel meter

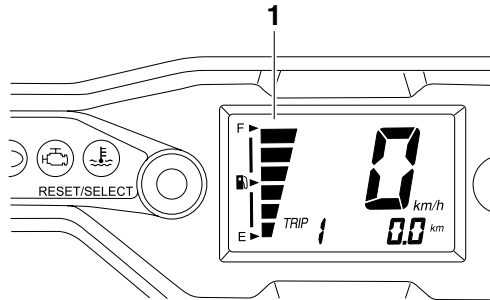

1. Fuel meter

The fuel meter indicates the amount of fuel in the fuel tank. The display segments of the fuel meter disappear towards “E” (Empty) as the fuel level decreases. When the last fuel meter segment starts flashing, refuel as soon as possible.

EAS20180

## IMPORTANT INFORMATION

EAS20190

### PREPARATION FOR REMOVAL AND DISASSEMBLY

1. Before removal and disassembly, remove all dirt, mud, dust and foreign material.

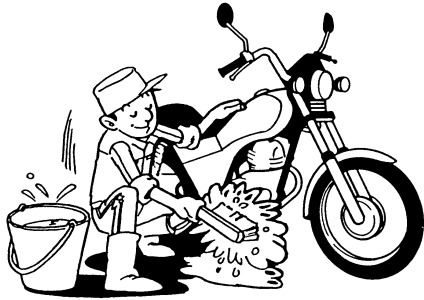

2. Use only the proper tools and cleaning equipment.

Refer to "SPECIAL TOOLS" on page 1-9.

3. When disassembling, always keep mated parts together. This includes gears, cylinders, pistons and other parts that have been "mated" through normal wear. Mated parts must always be reused or replaced as an assembly.

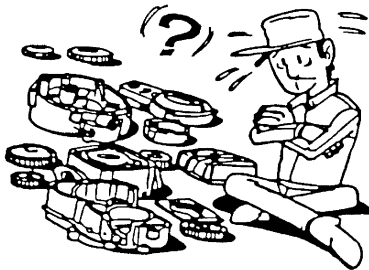

4. During disassembly, clean all of the parts and place them in trays in the order of disassembly. This will speed up assembly and allow for the correct installation of all parts.
5. Keep all parts away from any source of fire.

EAS20200

### REPLACEMENT PARTS

Use only genuine Yamaha parts for all replacements. Use oil and grease recommended by Yamaha for all lubrication jobs. Other brands may be similar in function and appearance, but inferior in quality.

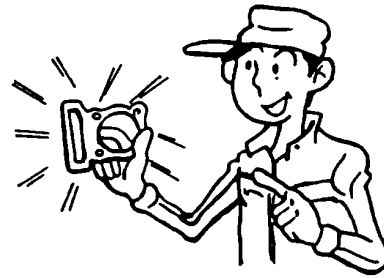

EAS20210

### GASKETS, OIL SEALS AND O-RINGS

1. When overhauling the engine, replace all gaskets, seals and O-rings. All gasket surfaces, oil seal lips and O-rings must be cleaned.
2. During reassembly, properly oil all mating parts and bearings and lubricate the oil seal lips with grease.

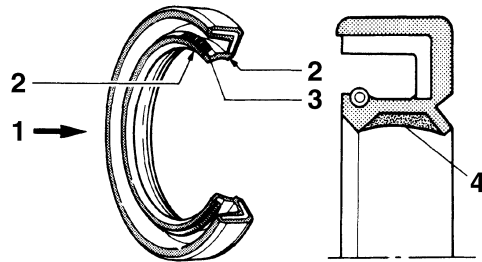

1. Oil
2. Lip
3. Spring
4. Grease

EAS20220

### LOCK WASHERS/PLATES AND COTTER PINS

After removal, replace all lock washers/plates "1" and cotter pins. After the bolt or nut has been tightened to specification, bend the lock tabs along a flat of the bolt or nut.

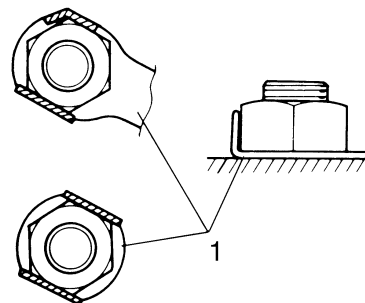

EAS20230

**BEARINGS AND OIL SEALS**

Install bearings "1" and oil seals "2" so that the manufacturer marks or numbers are visible. When installing oil seals, lubricate the oil seal lips with a light coat of lithium-soap-based grease. Oil bearings liberally when installing, if appropriate.

ECA13300

**NOTICE**

**Do not spin the bearing with compressed air because this will damage the bearing surfaces.**

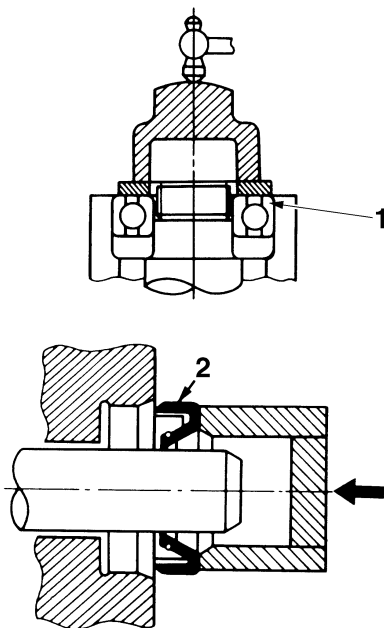

EAS20240

**CIRCLIPS**

Before reassembly, check all circlips carefully and replace damaged or distorted circlips. Always replace piston pin clips after one use. When installing a circlip "1", make sure the sharp-edged corner "2" is positioned opposite the thrust "3" that the circlip receives.

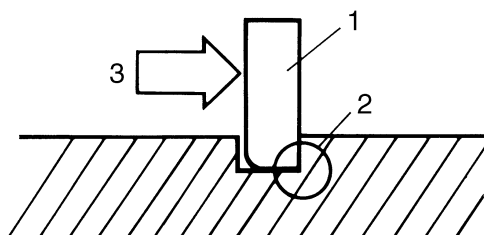

EAS20250

## CHECKING THE CONNECTIONS

Check the leads, couplers, and connectors for stains, rust, moisture, etc.

### 1. Disconnect:

- Lead
- Coupler
- Connector

### 2. Check:

- Lead
- Coupler
- Connector

Moisture → Dry with an air blower.

Rust/stains → Connect and disconnect several times.

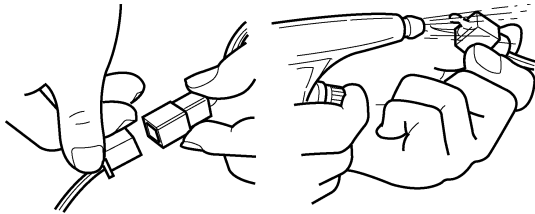

### 3. Check:

- All connections
- Loose connection → Connect properly.

### TIP

If the pin "1" on the terminal is flattened, bend it up.

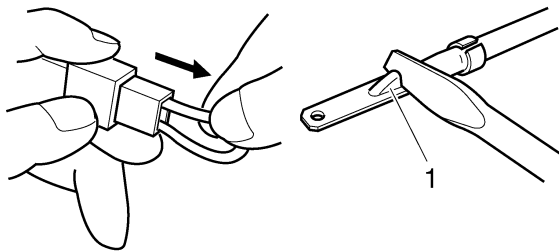

### 4. Connect:

- Lead
- Coupler
- Connector

### TIP

Make sure all connections are tight.

### 5. Check:

- Continuity  
(with the pocket tester)



**Pocket tester**  
**90890-03112**  
**Analog pocket tester**  
**YU-03112-C**

### TIP

- If there is no continuity, clean the terminals.
- When checking the wire harness, perform steps (1) to (3).
- As a quick remedy, use a contact revitalizer available at most part stores.

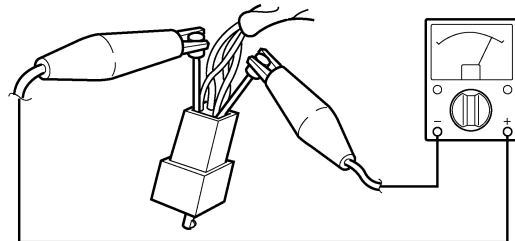
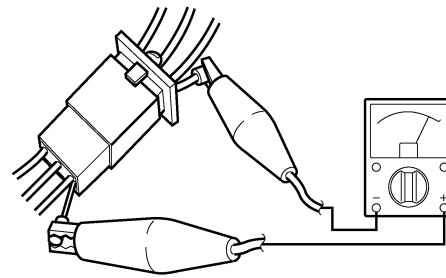

EAS20260

## SPECIAL TOOLS

The following special tools are necessary for complete and accurate tune-up and assembly. Use only the appropriate special tools as this will help prevent damage caused by the use of inappropriate tools or improvised techniques. Special tools, part numbers or both may differ depending on the country. When placing an order, refer to the list provided below to avoid any mistakes.

### TIP

- For U.S.A. and Canada, use part number starting with “YM-”, “YU-”, or “ACC-”.
- For others, use part number starting with “90890-”.

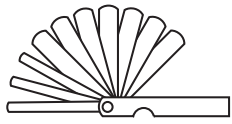
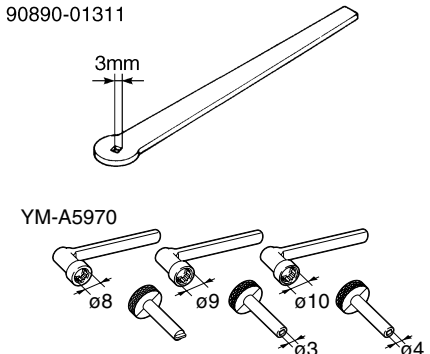
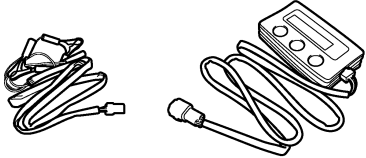
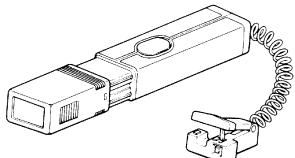

Tool name/Tool No.	Illustration	Reference pages
Pocket tester 90890-03112 Analog pocket tester YU-03112-C		1-8, 5-36, 8-63, 8-64, 8-65, 8-67, 8-68, 8-69, 8-70, 8-71, 8-72, 8-73, 8-74, 8-75, 8-76, 8-77
Thickness gauge 90890-03180 Feeler gauge set YU-26900-9		3-4, 5-43
Tappet adjusting tool 90890-01311 Six piece tappet set YM-A5970		3-5
FI diagnostic tool 90890-03182		3-5, 8-35
Timing light 90890-03141 Inductive clamp timing light YU-03141		3-8

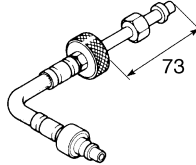
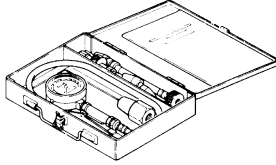
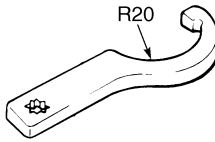
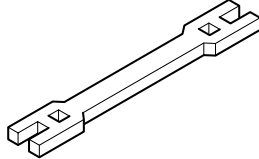
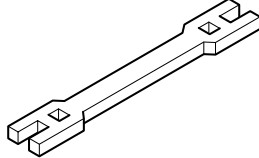
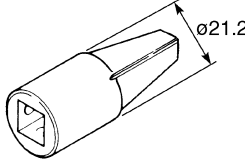
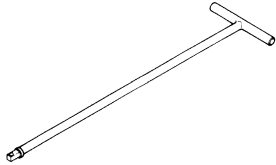
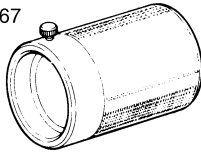
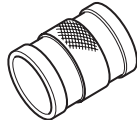

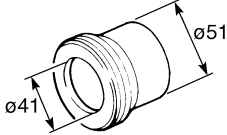
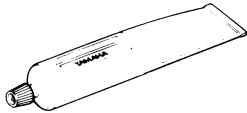
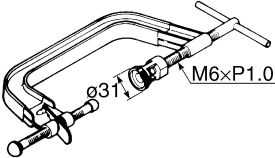
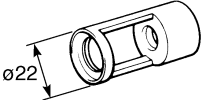
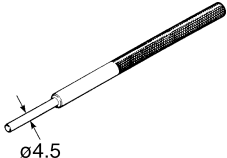
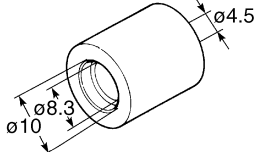
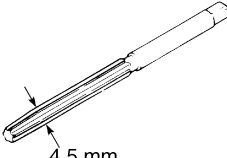
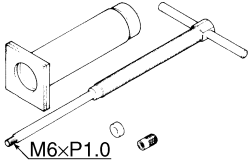
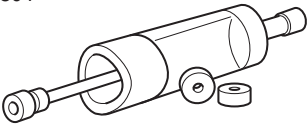
Tool name/Tool No.	Illustration	Reference pages
Extension 90890-04082		3-9
Compression gauge 90890-03081 Engine compression tester YU-33223		3-9
Steering nut wrench 90890-01403 Exhaust flange nut wrench YU-A9472		3-22, 4-58
Spoke nipple wrench (8-9) 90890-01522 YM-01522		3-25
Spoke nipple wrench (10-11) 90890-01523 YM-01523		3-25
Damper rod holder 90890-01460		4-51, 4-52
T-handle 90890-01326 T-handle 3/8" drive 60 cm long YM-01326		4-51, 4-52
Fork seal driver weight 90890-01367 Replacement hammer YM-A9409-7	90890-01367   YM-A9409-7/YM-A5142-4 	4-52, 4-53

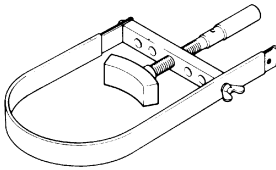
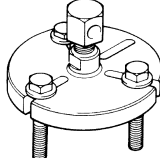
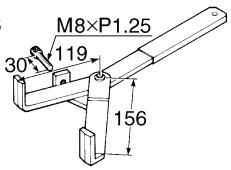
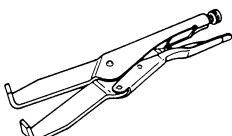
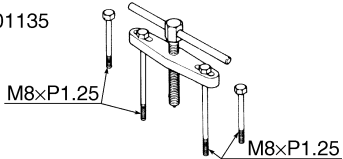
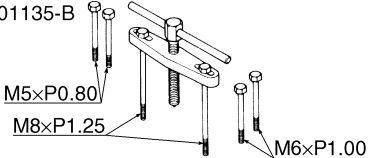
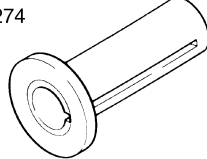
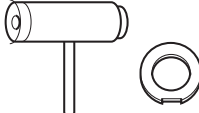
Tool name/Tool No.	Illustration	Reference pages
Fork seal driver attachment (ø41) 90890-01381 Replacement 41 mm YM-A5142-2		4-52
Yamaha bond No. 1215 90890-85505 (Three Bond No.1215®)		5-12, 5-33, 5-60
Valve spring compressor 90890-04019 YM-04019		5-18, 5-23
Valve spring compressor attachment 90890-04108 Valve spring compressor adapter 22 mm YM-04108		5-18, 5-23
Valve guide remover (ø4.5) 90890-04116 Valve guide remover (4.5 mm) YM-04116		5-19
Valve guide installer (ø4.5) 90890-04117 Valve guide installer (4.5 mm) YM-04117		5-19
Valve guide reamer (ø4.5) 90890-04118 Valve guide reamer (4.5 mm) YM-04118		5-19
Piston pin puller set 90890-01304 Piston pin puller YU-01304	90890-01304  YU-01304 	5-25

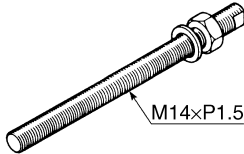
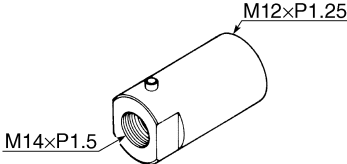
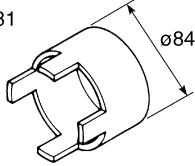
Tool name/Tool No.	Illustration	Reference pages
Sheave holder 90890-01701 Primary clutch holder YS-01880-A		5-31, 5-32, 5-33
Flywheel puller 90890-01362 Heavy duty puller YU-33270-B		5-31
Universal clutch holder 90890-04086 YM-91042	<p data-bbox="758 739 877 761">90890-04086</p>  <p data-bbox="877 772 917 795">30°</p> <p data-bbox="933 772 981 795">119</p> <p data-bbox="997 828 1037 851">156</p> <p data-bbox="933 739 1037 761">M8×P1.25</p> <p data-bbox="758 929 853 952">YM-91042</p> 	5-42, 5-45
Crankcase separating tool 90890-01135 Crankcase separator YU-01135-B	<p data-bbox="758 1108 877 1131">90890-01135</p>  <p data-bbox="829 1187 933 1209">M8×P1.25</p> <p data-bbox="1069 1243 1173 1265">M8×P1.25</p> <p data-bbox="758 1299 877 1321">YU-01135-B</p>  <p data-bbox="798 1377 901 1400">M5×P0.80</p> <p data-bbox="798 1411 901 1433">M8×P1.25</p> <p data-bbox="1061 1433 1165 1456">M6×P1.00</p>	5-63
Crankshaft installer pot 90890-01274 Installing pot YU-90058	<p data-bbox="758 1489 877 1512">90890-01274</p>  <p data-bbox="758 1680 949 1702">YU-90058/YU-90059</p> 	5-64

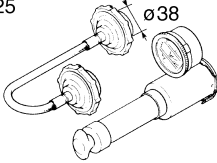
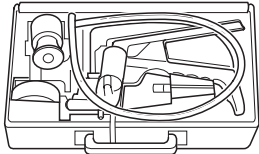
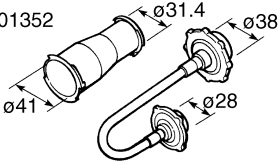
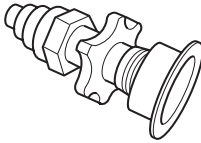
Tool name/Tool No.	Illustration	Reference pages
Crankshaft installer bolt 90890-01275 Bolt YU-90060		5-64
Adapter (M12) 90890-01278 Adapter #3 YU-90063		5-64
Spacer (crankshaft installer) 90890-04081 Pot spacer YM-91044	90890-04081  YM-91044 	5-64
Radiator cap tester 90890-01325 Radiator pressure tester YU-24460-01	90890-01325  YU-24460-01 	6-3
Radiator cap tester adapter 90890-01352 Radiator pressure tester adapter YU-33984	90890-01352  YU-33984 	6-3

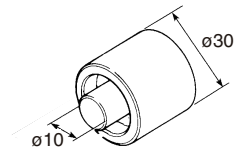
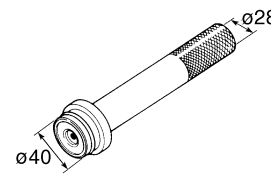
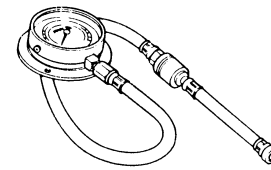
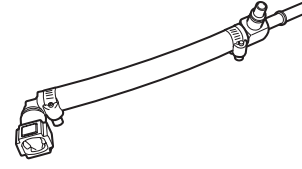
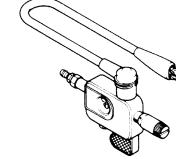
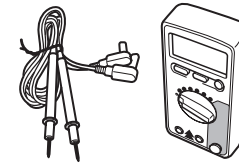
Tool name/Tool No.	Illustration	Reference pages
Mechanical seal installer 90890-04145		6-8
Middle driven shaft bearing driver 90890-04058 Bearing driver 40 mm YM-04058		6-8
Pressure gauge 90890-03153 YU-03153		7-3
Fuel pressure adapter 90890-03186		7-3
Ignition checker 90890-06754 Opama pet-4000 spark checker YM-34487		8-71
Digital circuit tester 90890-03174 Model 88 Multimeter with tachometer YU-A1927		8-75



## SPECIFICATIONS

<b>GENERAL SPECIFICATIONS</b> .....	2-1
<b>ENGINE SPECIFICATIONS</b> .....	2-2
<b>CHASSIS SPECIFICATIONS</b> .....	2-9
<b>ELECTRICAL SPECIFICATIONS</b> .....	2-12
<b>TIGHTENING TORQUES</b> .....	2-15
GENERAL TIGHTENING TORQUE SPECIFICATIONS .....	2-15
ENGINE TIGHTENING TORQUES .....	2-16
CHASSIS TIGHTENING TORQUES .....	2-19
<b>LUBRICATION POINTS AND LUBRICANT TYPES</b> .....	2-23
ENGINE .....	2-23
CHASSIS .....	2-25
<b>LUBRICATION SYSTEM CHART AND DIAGRAMS</b> .....	2-27
ENGINE OIL LUBRICATION CHART .....	2-27
LUBRICATION DIAGRAMS .....	2-29
<b>COOLING SYSTEM DIAGRAMS</b> .....	2-33
<b>CABLE ROUTING</b> .....	2-35

EAS20280

---

**GENERAL SPECIFICATIONS**

---

**Model**

Model	WR125R 22B1 WR125X 22B2
-------	----------------------------

---

**Dimensions**

Overall length	WR125R 2125 mm (83.7 in) WR125X 2090 mm (82.3 in)
Overall width	835 mm (32.9 in)
Overall height	WR125R 1285 mm (50.6 in) WR125X 1260 mm (49.6 in)
Seat height	WR125R 930 mm (36.6 in) WR125X 920 mm (36.2 in)
Wheelbase	1430 mm (56.3 in)
Ground clearance	WR125R 265 mm (10.43 in) WR125X 255 mm (10.04 in)
Minimum turning radius	2200 mm (86.6 in)

---

**Weight**

With oil and fuel	WR125R 133.0 kg (293 lb) WR125X 137.0 kg (302 lb)
Maximum load	185 kg (408 lb)



EAS20290

**ENGINE SPECIFICATIONS****Engine**

Engine type	Liquid cooled 4-stroke, SOHC
Displacement	124.7 cm <sup>3</sup>
Cylinder arrangement	Forward-inclined single cylinder
Bore × stroke	52.0 × 58.6 mm (2.05 × 2.31 in)
Compression ratio	11.20 :1
Standard compression pressure (at sea level)	550 kPa/600 r/min (5.5 kgf/cm <sup>2</sup> /600 r/min, 78.2 psi/600 r/min)
Minimum–maximum	480–620 kPa (4.8–6.2 kgf/cm <sup>2</sup> , 68.3–88.2 psi)
Starting system	Electric starter

**Fuel**

Recommended fuel	Premium unleaded gasoline only
Fuel tank capacity	8.5 L (2.25 US gal, 1.87 Imp.gal)
Fuel reserve amount	1.6 L (0.42 US gal, 0.35 Imp.gal)

**Engine oil**

Lubrication system	Wet sump
Type	SAE 10W-30, SAE 10W-40, SAE 15W-40, SAE 20W-40 or SAE 20W-50
Recommended engine oil grade	API service SG type or higher, JASO standard MA
Engine oil quantity	
Total amount	1.15 L (1.22 US qt, 1.01 Imp.qt)
Without oil filter element replacement	0.95 L (1.00 US qt, 0.84 Imp.qt)
With oil filter element replacement	1.00 L (1.06 US qt, 0.88 Imp.qt)

**Oil filter**

Oil filter type	Paper
-----------------	-------

**Oil pump**

Oil pump type	Trochoid
Inner-rotor-to-outer-rotor-tip clearance	Less than 0.150 mm (0.0059 in)
Limit	0.23 mm (0.0091 in)
Outer-rotor-to-oil-pump-housing clearance	0.130–0.180 mm (0.0051–0.0071 in)
Limit	0.25 mm (0.0098 in)
Oil-pump-housing-to-inner-and-outer-rotor clearance	0.06–0.11 mm (0.0024–0.0043 in)
Limit	0.18 mm (0.0071 in)
Relief valve operating pressure	39.2–78.4 kPa (0.39–0.78 kgf/cm <sup>2</sup> , 5.7–11.4 psi)
Pressure check location	Check bolt on cylinder head body

**Cooling system**

Radiator capacity (including all routes)	1.10 L (1.16 US qt, 0.97 Imp.qt)
Coolant reservoir capacity (up to the maximum level mark)	0.25 L (0.26 US qt, 0.22 Imp.qt)
Radiator cap opening pressure	108.0–137.4 kPa (1.08–1.37 kgf/cm <sup>2</sup> , 15.7–19.9 psi)
Thermostat	
Model/manufacturer	5YP/NIPPON THERMOSTAT

Valve opening temperature	80.5–83.5 °C (176.90–182.30 °F)
Valve full open temperature	95.0 °C (203.00 °F)
Valve lift (full open)	3.0 mm (0.12 in)
Radiator core	
Width	128.0 mm (5.04 in)
Height	258.0 mm (10.16 in)
Depth	24.0 mm (0.94 in)
Water pump	
Water pump type	Single suction centrifugal pump
Reduction ratio	19/38 (0.500)

### Spark plug (s)

Manufacturer/model	NGK/CR8E
Spark plug gap	0.7–0.8 mm (0.028–0.031 in)

### Cylinder head

Volume	9.90–10.50 cm <sup>3</sup> (0.60–0.64 cu.in)
Warpage limit	0.03 mm (0.0012 in)

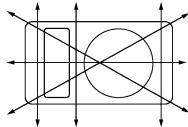

### Camshaft

Drive system	Chain drive (left)
Camshaft lobe dimensions	
Intake A	30.225–30.325 mm (1.1900–1.1939 in)
Limit	30.125 mm (1.1860 in)
Intake B	25.127–25.227 mm (0.9893–0.9932 in)
Limit	25.027 mm (0.9853 in)
Exhaust A	30.232–30.332 mm (1.1902–1.1942 in)
Limit	30.132 mm (1.1863 in)
Exhaust B	25.065–25.165 mm (0.9868–0.9907 in)
Limit	24.965 mm (0.9829 in)

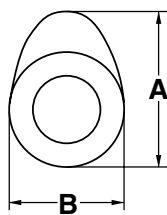

Camshaft runout limit	0.030 mm (0.0012 in)
-----------------------	----------------------

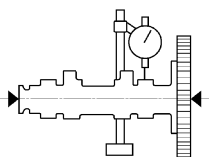

### Timing chain

Model/number of links	DID SCR-0404SV/96
-----------------------	-------------------

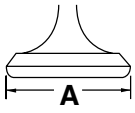
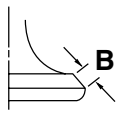
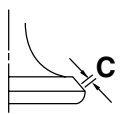
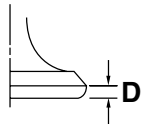
Tensioning system	Automatic
<b>Rocker arm/rocker arm shaft</b>	
Rocker arm inside diameter	9.985–10.000 mm (0.3931–0.3937 in)
Limit	10.015 mm (0.3943 in)
Rocker arm shaft outside diameter	9.966–9.976 mm (0.3924–0.3928 in)
Limit	9.941 mm (0.3914 in)
Rocker-arm-to-rocker-arm-shaft clearance	0.009–0.034 mm (0.0004–0.0013 in)
Limit	0.074 mm (0.0029 in)
<b>Valve, valve seat, valve guide</b>	
Valve clearance (cold)	
Intake	0.10–0.14 mm (0.0039–0.0055 in)
Exhaust	0.20–0.24 mm (0.0079–0.0094 in)
Valve dimensions	
Valve head diameter A (intake)	19.40–19.60 mm (0.7638–0.7717 in)
Valve head diameter A (exhaust)	16.90–17.10 mm (0.6654–0.6732 in)
	
Valve face width B (intake)	1.538–2.138 mm (0.0606–0.0842 in)
Valve face width B (exhaust)	1.538–2.138 mm (0.0606–0.0842 in)
	
Valve seat width C (intake)	0.90–1.10 mm (0.0354–0.0433 in)
Limit	1.6 mm (0.06 in)
Valve seat width C (exhaust)	0.90–1.10 mm (0.0354–0.0433 in)
Limit	1.6 mm (0.06 in)
	
Valve margin thickness D (intake)	0.50–0.90 mm (0.0197–0.0354 in)
Valve margin thickness D (exhaust)	0.50–0.90 mm (0.0197–0.0354 in)
	
Valve stem diameter (intake)	4.475–4.490 mm (0.1762–0.1768 in)
Limit	4.445 mm (0.1750 in)
Valve stem diameter (exhaust)	4.460–4.475 mm (0.1756–0.1762 in)
Limit	4.430 mm (0.1744 in)
Valve guide inside diameter (intake)	4.500–4.512 mm (0.1772–0.1776 in)
Limit	4.550 mm (0.1791 in)
Valve guide inside diameter (exhaust)	4.500–4.512 mm (0.1772–0.1776 in)
Limit	4.550 mm (0.1791 in)
Valve-stem-to-valve-guide clearance (intake)	0.010–0.037 mm (0.0004–0.0015 in)
Limit	0.080 mm (0.0032 in)

Valve-stem-to-valve-guide clearance (exhaust)	0.025–0.052 mm (0.0010–0.0020 in)
Limit	0.100 mm (0.0039 in)
Valve stem runout	0.010 mm (0.0004 in)

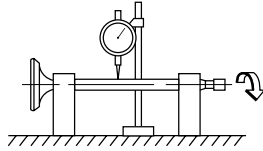

Cylinder head valve seat width (intake)	0.90–1.10 mm (0.0354–0.0433 in)
Limit	1.6 mm (0.06 in)
Cylinder head valve seat width (exhaust)	0.90–1.10 mm (0.0354–0.0433 in)
Limit	1.6 mm (0.06 in)

### Valve spring

Free length (intake)	41.71 mm (1.64 in)
Limit	39.62 mm (1.56 in)
Free length (exhaust)	41.71 mm (1.64 in)
Limit	39.62 mm (1.56 in)
Installed length (intake)	35.30 mm (1.39 in)
Installed length (exhaust)	35.30 mm (1.39 in)
Spring rate K1 (intake)	23.54 N/mm (2.40 kgf/mm, 134.41 lb/in)
Spring rate K2 (intake)	36.58 N/mm (3.73 kgf/mm, 208.87 lb/in)
Spring rate K1 (exhaust)	23.54 N/mm (2.40 kgf/mm, 134.41 lb/in)
Spring rate K2 (exhaust)	36.58 N/mm (3.73 kgf/mm, 208.87 lb/in)
Installed compression spring force (intake)	140.00–162.00 N (14.28–16.52 kgf, 31.47–36.42 lbf)
Installed compression spring force (exhaust)	140.00–162.00 N (14.28–16.52 kgf, 31.47–36.42 lbf)
Spring tilt (intake)	2.5°/1.8 mm
Spring tilt (exhaust)	2.5°/1.8 mm

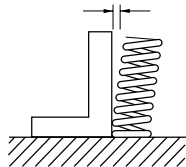

Winding direction (intake)	Clockwise
Winding direction (exhaust)	Clockwise

### Cylinder

Bore	52.000–52.010 mm (2.0472–2.0476 in)
Wear limit	52.110 mm (2.0516 in)
Taper limit	0.050 mm (0.0020 in)
Out of round limit	0.005 mm (0.0002 in)

### Piston

Piston-to-cylinder clearance	0.015–0.048 mm (0.0006–0.0019 in)
Limit	0.15 mm (0.0059 in)
Diameter D	51.962–51.985 mm (2.0457–2.0466 in)

Height H 5.0 mm (0.20 in)

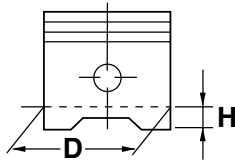

Offset 0.50 mm (0.0197 in)  
 Offset direction Intake side  
 Piston pin bore inside diameter 14.002–14.013 mm (0.5513–0.5517 in)  
 Limit 14.043 mm (0.5529 in)  
 Piston pin outside diameter 13.995–14.000 mm (0.5510–0.5512 in)  
 Limit 13.975 mm (0.5502 in)  
 Piston-pin-to-piston-pin-bore clearance 0.002–0.018 mm (0.0001–0.0007 in)  
 Limit 0.068 mm (0.0027 in)

### Piston ring

#### Top ring

Ring type Barrel  
 Dimensions (B × T) 0.80 × 1.90 mm (0.03 × 0.07 in)

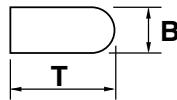

End gap (installed) 0.10–0.25 mm (0.0039–0.0098 in)  
 Limit 0.50 mm (0.0197 in)  
 Ring side clearance 0.030–0.065 mm (0.0012–0.0026 in)  
 Limit 0.100 mm (0.0039 in)

#### 2nd ring

Ring type Taper  
 Dimensions (B × T) 0.80 × 2.10 mm (0.03 × 0.08 in)

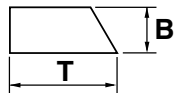

End gap (installed) 0.10–0.25 mm (0.0039–0.0098 in)  
 Limit 0.60 mm (0.0236 in)  
 Ring side clearance 0.020–0.055 mm (0.0008–0.0022 in)  
 Limit 0.100 mm (0.0039 in)

#### Oil ring

Dimensions (B × T) 1.50 × 1.95 mm (0.06 × 0.08 in)

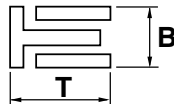

End gap (installed) 0.20–0.70 mm (0.0079–0.0276 in)  
 Ring side clearance 0.040–0.160 mm (0.0016–0.0063 in)

### Crankshaft

Width A 47.95–48.00 mm (1.888–1.890 in)

Runout limit C	0.030 mm (0.0012 in)
Big end side clearance D	0.110–0.410 mm (0.0043–0.0161 in)
Big end radial clearance E	0.004–0.014 mm (0.0002–0.0006 in)

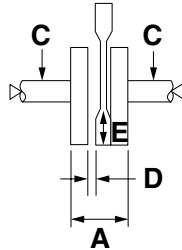

---

**Balancer**

Balancer drive method	Gear
-----------------------	------

---

**Clutch**

Clutch type	Wet, multiple-disc
Clutch release method	Inner push, cam push
Clutch lever free play	10.0–15.0 mm (0.39–0.59 in)
Friction plate 1 thickness	2.90–3.10 mm (0.114–0.122 in)
Wear limit	2.80 mm (0.1102 in)
Plate quantity	1 pc
Friction plate 3 thickness	2.90–3.10 mm (0.114–0.122 in)
Wear limit	2.80 mm (0.1102 in)
Plate quantity	3 pcs
Friction plate 2 thickness	2.90–3.10 mm (0.114–0.122 in)
Wear limit	2.80 mm (0.1102 in)
Plate quantity	1 pc
Clutch plate thickness	1.45–1.75 mm (0.057–0.069 in)
Plate quantity	4 pcs
Warpage limit	0.20 mm (0.0079 in)
Clutch spring free length	38.71 mm (1.52 in)
Minimum length	36.77 mm (1.45 in)
Spring quantity	4 pcs
Long clutch push rod bending limit	0.500 mm (0.0197 in)

---

**Transmission**

Transmission type	Constant mesh 6-speed
Primary reduction system	Helical gear
Primary reduction ratio	73/24 (3.042)
Secondary reduction system	Chain drive
Secondary reduction ratio	53/14 (3.786)
Operation	Left foot operation
Gear ratio	
1st	34/12 (2.833)
2nd	30/16 (1.875)
3rd	30/22 (1.364)
4th	24/21 (1.143)
5th	22/23 (0.957)
6th	21/25 (0.840)
Main axle runout limit	0.08 mm (0.0032 in)

Drive axle runout limit	0.08 mm (0.0032 in)
<b>Shifting mechanism</b>	
Shift mechanism type	Shift drum and guide bar
Shift fork L thickness	5.76–5.89 mm (0.2268–0.2319 in)
Shift fork C, R thickness	4.76–4.89 mm (0.1874–0.1925 in)
<b>Decompression device</b>	
Device type	Auto decomp
<b>Air filter</b>	
Air filter element	Dry element
<b>Fuel pump</b>	
Pump type	Electrical
Model/manufacturer	22B/AISAN
Output pressure	250.0 kPa (2.50 kgf/cm <sup>2</sup> , 36.3 psi)
<b>Fuel injector</b>	
Model/quantity	1100–87K00/1
Manufacturer	AISAN
<b>Throttle body</b>	
Type/quantity	SE AC28–2/1
Manufacturer	MIKUNI
ID mark	5D71 00
<b>Fuel injection sensor</b>	
Crankshaft position sensor resistance	248–372 $\Omega$ at 20 °C (68 °F)
Intake air pressure sensor output voltage	4.70–5.20 V
Intake air temperature sensor resistance	5.7–6.3 k $\Omega$ at 0 °C (32 °F)
Coolant temperature sensor resistance	2.32–2.59 k $\Omega$ at 20 °C (68 °F) 310–326 $\Omega$ at 80 °C (176 °F)
<b>Idling condition</b>	
Engine idling speed	1400–1600 r/min
Water temperature	85.0–95.0 °C (185.00–203.00 °F)
Oil temperature	55.0–65.0 °C (131.00–149.00 °F)
Throttle cable free play	3.0–5.0 mm (0.12–0.20 in)

EAS20300

**CHASSIS SPECIFICATIONS****Chassis**

Frame type	Double cradle
Caster angle	WR125R 27.00° WR125X 25.50°
Trail	WR125R 107.0 mm (4.21 in) WR125X 78.5 mm (3.09 in)

**Front wheel**

Wheel type	Spoke wheel
Rim size	WR125R 21 × 1.6 WR125X 17 × 3
Rim material	WR125R Steel WR125X Aluminum
Wheel travel	WR125R 240.0 mm (9.45 in) WR125X 210.0 mm (8.27 in)
Radial wheel runout limit	1.0 mm (0.04 in)
Lateral wheel runout limit	0.5 mm (0.02 in)
Wheel axle bending limit	0.20 mm (0.01 in)

**Rear wheel**

Wheel type	Spoke wheel
Rim size	WR125R 18 × 1.85 WR125X 17 × 3.5
Rim material	WR125R Steel WR125X Aluminum
Wheel travel	230.0 mm (9.06 in)
Radial wheel runout limit	1.0 mm (0.04 in)
Lateral wheel runout limit	0.5 mm (0.02 in)
Wheel axle bending limit	0.25 mm (0.01 in)

**Front tire**

Type	With tube
Size	WR125R 80/90–21 M/C 48P WR125R 80/90–21 M/C 48S WR125R 80/90–21 M/C 48R WR125X 110/70–17 M/C 54H
Manufacturer/model	WR125R MICHELIN/T63 WR125R PIRELLI/MT21 WR125R PIRELLI/SCORPION A/T WR125R MICHELIN/SIRAC WR125X PIRELLI/SPORT DEMON
Wear limit (front)	1.6 mm (0.06 in)

**Rear tire**

Type	With tube
Size	WR125R 110/80–18 M/C 58P WR125R 110/80–18 M/C 58S WR125R 110/80–18 M/C 58R WR125X 140/70–17 M/C 66H



Manufacturer/model	WR125R MICHELIN/T63 WR125R PIRELLI/MT21 WR125R PIRELLI/SCORPION A/T WR125R MICHELIN/SIRAC WR125X PIRELLI/SPORT DEMON
Wear limit (rear)	1.6 mm (0.06 in)
<b>Tire air pressure (measured on cold tires)</b>	
Loading condition	0–90 kg (0–198 lb)
Front	200 kPa (2.00 kgf/cm <sup>2</sup> , 29 psi)
Rear	200 kPa (2.00 kgf/cm <sup>2</sup> , 29 psi)
Loading condition	90–185 kg (198–408 lb)
Front	200 kPa (2.00 kgf/cm <sup>2</sup> , 29 psi)
Rear	225 kPa (2.25 kgf/cm <sup>2</sup> , 33 psi)
<b>Front brake</b>	
Type	Single disc brake
Operation	Right hand operation
Front disc brake	
Disc outside diameter × thickness	WR125R 240.0 × 4.0 mm (9.45 × 0.16 in) WR125X 298.0 × 4.5 mm (11.73 × 0.18 in)
Brake disc thickness limit	WR125R 3.5 mm (0.14 in) WR125X 4.0 mm (0.16 in)
Brake disc deflection limit	0.15 mm (0.0059 in)
Brake pad lining thickness (inner)	5.0 mm (0.20 in)
Limit	1.0 mm (0.04 in)
Brake pad lining thickness (outer)	5.0 mm (0.20 in)
Limit	1.0 mm (0.04 in)
Master cylinder inside diameter	13.00 mm (0.51 in)
Caliper cylinder inside diameter	27.00 mm × 2 (1.06 in × 2)
Recommended fluid	DOT 4
<b>Rear brake</b>	
Type	Single disc brake
Operation	Right foot operation
Brake pedal position	12.0 mm (0.47 in)
Rear disc brake	
Disc outside diameter × thickness	220.0 × 4.5 mm (8.66 × 0.18 in)
Brake disc thickness limit	4.0 mm (0.16 in)
Brake disc deflection limit	0.15 mm (0.0059 in)
Brake pad lining thickness (inner)	6.0 mm (0.24 in)
Limit	1.0 mm (0.04 in)
Brake pad lining thickness (outer)	6.0 mm (0.24 in)
Limit	1.0 mm (0.04 in)
Master cylinder inside diameter	12.7 mm (0.50 in)
Caliper cylinder inside diameter	30.23 mm × 1 (1.19 in × 1)
Recommended fluid	DOT 4
<b>Steering</b>	
Steering bearing type	Ball and taper roller bearing
Center to lock angle (left)	43.0°
Center to lock angle (right)	43.0°

**Front suspension**

Type	Telescopic fork
Spring/shock absorber type	Coil spring/oil damper
Front fork travel	WR125R 240.0 mm (9.45 in) WR125X 210.0 mm (8.27 in)
Fork spring free length	520.0 mm (20.47 in)
Limit	468.0 mm (18.43 in)
Installed length	WR125R 517.0 mm (20.35 in) WR125X 514.0 mm (20.24 in)
Spring rate K1	4.00 N/mm (0.41 kgf/mm, 22.84 lb/in)
Spring stroke K1	WR125R 0.0–240.0 mm (0.00–9.45 in) WR125X 0.0–210.0 mm (0.00–8.27 in)
Inner tube outer diameter	41.0 mm (1.61 in)
Inner tube bending limit	0.3 mm (0.01 in)
Optional spring available	No
Recommended oil	Fork oil 10W or equivalent
Quantity	WR125R 560.0 cm <sup>3</sup> (18.93 US oz, 19.75 Imp.oz) WR125X 610.0 cm <sup>3</sup> (20.62 US oz, 21.51 Imp.oz)
Level	WR125R 165.0 mm (6.50 in) WR125X 145.0 mm (5.71 in)

**Rear suspension**

Type	Swingarm (monocross)
Spring/shock absorber type	WR125R Coil spring/gas-oil damper WR125X Coil spring/oil damper
Rear shock absorber assembly travel	74.0 mm (2.91 in)
Spring free length	224.0 mm (8.82 in)
Installed length	203.0 mm (7.99 in)
Spring rate K1	80.00 N/mm (8.16 kgf/mm, 456.80 lb/in)
Spring stroke K1	0.0–66.0 mm (0.00–2.60 in)
Optional spring available	No
Spring preload adjusting positions	
Minimum	1
Standard	3
Maximum	7

**Swingarm**

Swingarm end free play limit (axial)	0 mm (0 in)
--------------------------------------	-------------

**Drive chain**

Type/manufacturer	428 ORM/REGINA
Number of links	132
Drive chain slack	40.0–50.0 mm (1.57–1.97 in)
15-link length limit	191.5 mm (7.54 in)

EAS20310

**ELECTRICAL SPECIFICATIONS****Voltage**

System voltage 12 V

**Ignition system**

Ignition system TCI (digital)  
 Advancer type Throttle position sensor and electrical  
 Ignition timing (B.T.D.C.) 10.0°/1400 r/min

**Engine control unit**

Model/manufacturer WR125R 22B00/YAMAHA  
 WR125X 22B10/YAMAHA

**Ignition coil**

Model/manufacturer 2JN/YAMAHA  
 Minimum ignition spark gap 6.0 mm (0.24 in)  
 Primary coil resistance 2.16–2.64  $\Omega$  at 20 °C (68 °F)  
 Secondary coil resistance 8.64–12.96 k $\Omega$  at 20 °C (68 °F)

**Spark plug cap**

Material Resin  
 Resistance 5.0 k $\Omega$

**AC magneto**

Model/manufacturer F22B/YAMAHA  
 Standard output 14.0 V, 20.8 A at 5000 r/min  
 Standard output 14.0 V, 160 W at 5000 r/min  
 Stator coil resistance 0.448–0.672  $\Omega$  at 20 °C (68 °F)

**Rectifier/regulator**

Regulator type Semi conductor-short circuit  
 Model/manufacturer SH629A-12/SHINDENGEN  
 Regulated voltage (DC) 14.1–14.9 V  
 Rectifier capacity (DC) 10.0 A  
 Withstand voltage 200.0 V

**Battery**

Model 12N5.5–4A  
 Voltage, capacity 12 V, 5.5 Ah  
 Specific gravity 1.280 at 20 °C (68 °F)  
 Manufacturer YUASA

**Headlight**

Bulb type Halogen bulb

**Bulb voltage, wattage × quantity**

Headlight 12 V, 35 W/35 W × 1  
 Auxiliary light 12 V, 5.0 W × 1  
 Tail/brake light 12 V, 21.0 W/5.0 W × 1  
 Front turn signal light 12 V, 10.0 W × 2  
 Rear turn signal light 12 V, 10.0 W × 2

License plate light	12 V, 5.0 W × 1
Meter lighting	LED
<b>Indicator light</b>	
Neutral indicator light	LED
Turn signal indicator light	LED
High beam indicator light	LED
Coolant temperature warning light	LED
Engine trouble warning light	LED
<b>Electric starting system</b>	
System type	Constant mesh
<b>Starter motor</b>	
Model/manufacture	5D7/YAMAHA
Power output	0.20 kW
Armature coil resistance	0.0315–0.0385 Ω
Brush overall length	7.0 mm (0.28 in)
Limit	3.50 mm (0.14 in)
Brush spring force	3.92–5.88 N (400–600 gf, 14.11–21.17 oz)
Commutator diameter	17.6 mm (0.69 in)
Limit	16.6 mm (0.65 in)
Mica undercut (depth)	1.35 mm (0.05 in)
<b>Starter relay</b>	
Model/manufacture	5TN/OMRON
Amperage	50.0 A
Coil resistance	54–66 Ω
<b>Horn</b>	
Horn type	Plane
Quantity	1 pc
Model/manufacture	HF-12/NIKKO
Maximum amperage	3.0 A
Coil resistance	1.06–1.11 Ω at 20 °C (68 °F)
<b>Turn signal relay</b>	
Model/manufacture	FE218BH/DENSO
Relay type	Full transistor
Built-in, self-canceling device	No
Turn signal blinking frequency	75–95 cycles/min
Wattage	10 W × 2.0 + 3.4 W
<b>Fuel sender unit</b>	
Model/manufacture	22B/AISAN
Sender unit resistance (full)	19.0–21.0 Ω at 20 °C (68 °F)
Sender unit resistance (empty)	137.0–143.0 Ω at 20 °C (68 °F)
<b>Starting circuit cut-off relay</b>	
Model/manufacture	ACA12115–4/MATSUSHITA
Coil resistance	72.0–88.0 Ω
Diode	Yes

---

**Headlight relay**

Model/manufacture	ACM33211 M05/MATSUSHITA
Coil resistance	96.0 $\Omega$

---

**Radiator fan**

Model/manufacture	SSW6101/PANASONIC
Running rpm	4800 r/min

---

**Fan motor relay**

Model/manufacture	ACM33211 M05/MATSUSHITA
Coil resistance	96.0 $\Omega$

---

**Fuses**

Main fuse	20.0 A
Headlight fuse	15.0 A
Signaling system fuse	7.5 A
Ignition fuse	7.5 A
Radiator fan fuse	5.0 A
Spare fuse	20.0 A
Spare fuse	15.0 A
Spare fuse	7.5 A
Spare fuse	5.0 A

EAS20320

## TIGHTENING TORQUES

EAS20330

### GENERAL TIGHTENING TORQUE SPECIFICATIONS

This chart specifies tightening torques for standard fasteners with a standard ISO thread pitch. Tightening torque specifications for special components or assemblies are provided for each chapter of this manual. To avoid warpage, tighten multi-fastener assemblies in a crisscross pattern and progressive stages until the specified tightening torque is reached. Unless otherwise specified, tightening torque specifications require clean, dry threads. Components should be at room temperature.

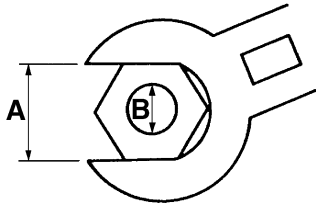













- A. Distance between flats
- B. Outside thread diameter

A (nut)	B (bolt)	General tightening torques		
		Nm	m·kgf	ft·lbf
10 mm	6 mm	6	0.6	4.3
12 mm	8 mm	15	1.5	11
14 mm	10 mm	30	3.0	22
17 mm	12 mm	55	5.5	40
19 mm	14 mm	85	8.5	61
22 mm	16 mm	130	13.0	94

EAS20340

## ENGINE TIGHTENING TORQUES

Item	Thread size	Q'ty	Tightening torque	Remarks
Cylinder head bolt	M8	4	22 Nm (2.2 m·kgf, 16 ft·lbf)	
Cylinder head bolt	M6	2	10 Nm (1.0 m·kgf, 7.2 ft·lbf)	
Spark plug	M10	1	13 Nm (1.3 m·kgf, 9.4 ft·lbf)	
Cylinder head cover bolt	M6	5	10 Nm (1.0 m·kgf, 7.2 ft·lbf)	
Oil check bolt	M6	1	7 Nm (0.7 m·kgf, 5.1 ft·lbf)	
Exhaust pipe stud bolt	M8	2	15 Nm (1.5 m·kgf, 11 ft·lbf)	
Coolant drain bolt	M6	1	7 Nm (0.7 m·kgf, 5.1 ft·lbf)	
Balancer driven gear nut	M10	1	50 Nm (5.0 m·kgf, 36 ft·lbf)	
Valve adjusting screw locknut	M5	4	7 Nm (0.7 m·kgf, 5.1 ft·lbf)	
Camshaft sprocket bolt	M8	1	30 Nm (3.0 m·kgf, 22 ft·lbf)	
Camshaft retainer bolt	M6	2	7 Nm (0.7 m·kgf, 5.1 ft·lbf)	
Timing chain guide (intake side) bolt	M6	1	10 Nm (1.0 m·kgf, 7.2 ft·lbf)	
Timing chain tensioner bolt	M6	2	10 Nm (1.0 m·kgf, 7.2 ft·lbf)	Yamaha bond No.1215 (Three Bond No.1215 ®)
Radiator bolt	M6	3	7 Nm (0.7 m·kgf, 5.1 ft·lbf)	
Radiator cap lock bolt	M3	1	1 Nm (0.1 m·kgf, 0.7 ft·lbf)	
Radiator fan bolt	M6	2	8 Nm (0.8 m·kgf, 5.8 ft·lbf)	
Radiator bracket bolt	M8	2	16 Nm (1.6 m·kgf, 11 ft·lbf)	
Coolant reservoir bolt	M6	2	7 Nm (0.7 m·kgf, 5.1 ft·lbf)	
Clutch cable guide bolt	M6	1	7 Nm (0.7 m·kgf, 5.1 ft·lbf)	
Water pump assembly bolt	M6	3	10 Nm (1.0 m·kgf, 7.2 ft·lbf)	
Water pump housing cover bolt	M6	4	10 Nm (1.0 m·kgf, 7.2 ft·lbf)	
Impeller shaft retainer bolt	M6	2	10 Nm (1.0 m·kgf, 7.2 ft·lbf)	
Thermostat cover bolt	M6	2	10 Nm (1.0 m·kgf, 7.2 ft·lbf)	
Oil pump assembly screw	M5	2	4 Nm (0.4 m·kgf, 2.9 ft·lbf)	
Engine oil drain plug	M35	1	32 Nm (3.2 m·kgf, 23 ft·lbf)	
Oil filter element cover bolt	M6	3	10 Nm (1.0 m·kgf, 7.2 ft·lbf)	
Oil baffle plate bolt	M6	2	10 Nm (1.0 m·kgf, 7.2 ft·lbf)	
Intake manifold bolt	M6	2	10 Nm (1.0 m·kgf, 7.2 ft·lbf)	
Fuel injector bolt	M6	1	12 Nm (1.2 m·kgf, 8.7 ft·lbf)	
Throttle cable locknut	M6	1	7 Nm (0.7 m·kgf, 5.1 ft·lbf)	
Throttle body joint clamp screw	M4	2	2 Nm (0.2 m·kgf, 1.4 ft·lbf)	
Air filter case joint clamp screw	M4	1	1 Nm (0.1 m·kgf, 0.7 ft·lbf)	

Item	Thread size	Q'ty	Tightening torque	Remarks
Air filter case bolt	M6	4	10 Nm (1.0 m·kgf, 7.2 ft·lbf)	
Air induction system reed valve bolt	M6	2	10 Nm (1.0 m·kgf, 7.2 ft·lbf)	
Exhaust pipe nut	M8	2	20 Nm (2.0 m·kgf, 14 ft·lbf)	
Muffler bolt	M8	2	27 Nm (2.7 m·kgf, 19 ft·lbf)	
Muffler clamp bolt	M8	1	18 Nm (1.8 m·kgf, 13 ft·lbf)	
Crankcase bolt	M6	13	10 Nm (1.0 m·kgf, 7.2 ft·lbf)	
Generator cover bolt	M6	7	10 Nm (1.0 m·kgf, 7.2 ft·lbf)	
Clutch cover bolt	M6	10	10 Nm (1.0 m·kgf, 7.2 ft·lbf)	
Starter clutch bolt	M6	3	14 Nm (1.4 m·kgf, 10 ft·lbf)	
Primary drive gear nut	M12	1	60 Nm (6.0 m·kgf, 43 ft·lbf)	
Clutch spring bolt	M6	4	12 Nm (1.2 m·kgf, 8.7 ft·lbf)	
Short clutch push rod locknut	M6	1	8 Nm (0.8 m·kgf, 5.8 ft·lbf)	
Clutch boss nut	M14	1	70 Nm (7.0 m·kgf, 50 ft·lbf)	
Clutch cable locknut	M6	1	7 Nm (0.7 m·kgf, 5.1 ft·lbf)	
Crankcase bearing retainer bolt	M6	2	7 Nm (0.7 m·kgf, 5.1 ft·lbf)	
Shift drum segment screw	M6	1	12 Nm (1.2 m·kgf, 8.7 ft·lbf)	
Stopper lever bolt	M6	1	10 Nm (1.0 m·kgf, 7.2 ft·lbf)	
Stator coil bolt	M6	3	10 Nm (1.0 m·kgf, 7.2 ft·lbf)	
Crankshaft position sensor bolt	M6	2	10 Nm (1.0 m·kgf, 7.2 ft·lbf)	
Generator rotor nut	M12	1	70 Nm (7.0 m·kgf, 50 ft·lbf)	
Neutral switch	M10	1	20 Nm (2.0 m·kgf, 14 ft·lbf)	
Starter motor bolt	M6	2	10 Nm (1.0 m·kgf, 7.2 ft·lbf)	
Coolant temperature sensor	M12	1	18 Nm (1.8 m·kgf, 13 ft·lbf)	

**Cylinder head tightening sequence:**

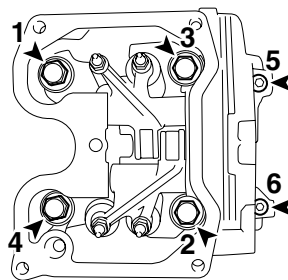



Generator cover tightening sequence:

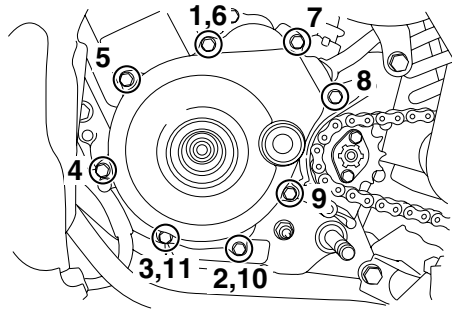

Clutch cover tightening sequence:

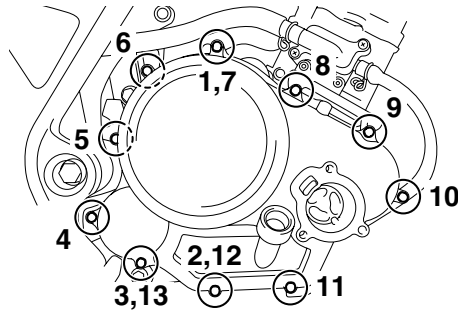

Crankcase tightening sequence:

**A**

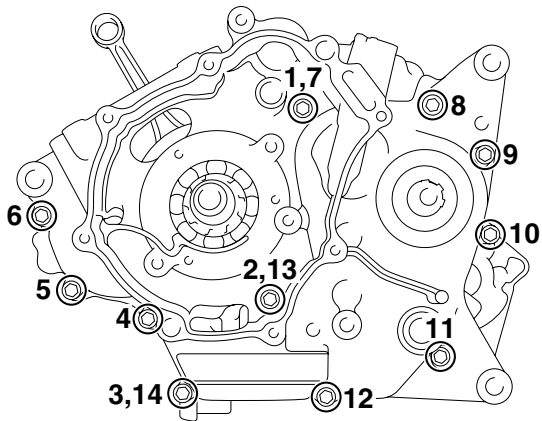

**B**

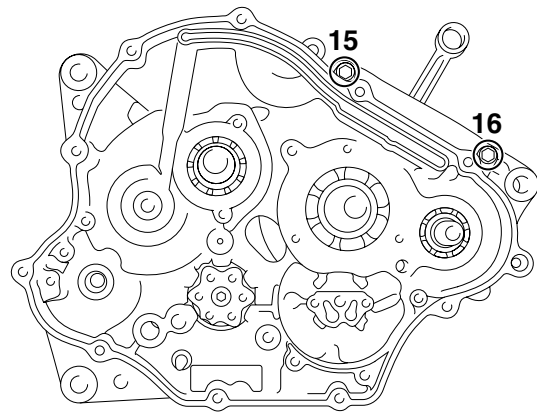









- A. Left crankcase
- B. Right crankcase

EAS20350

## CHASSIS TIGHTENING TORQUES

Item	Thread size	Q'ty	Tightening torque	Remarks
Engine front lower bracket nut	M10	2	67 Nm (6.7 m·kgf, 48 ft·lbf)	
Engine front lower mounting nut	M10	1	67 Nm (6.7 m·kgf, 48 ft·lbf)	
Engine rear lower mounting nut	M10	1	67 Nm (6.7 m·kgf, 48 ft·lbf)	
Engine rear upper bracket bolt	M8	2	33 Nm (3.3 m·kgf, 24 ft·lbf)	
Engine rear upper mounting nut	M10	1	67 Nm (6.7 m·kgf, 48 ft·lbf)	
Engine front upper bracket bolt	M10	4	46 Nm (4.6 m·kgf, 33 ft·lbf)	
Engine front upper mounting nut	M10	1	67 Nm (6.7 m·kgf, 48 ft·lbf)	
Drive chain tensioner bolt (upper and lower)	M8	2	23 Nm (2.3 m·kgf, 17 ft·lbf)	
Drive sprocket cover bolt	M6	2	10 Nm (1.0 m·kgf, 7.2 ft·lbf)	
Drive sprocket retainer bolt	M6	2	10 Nm (1.0 m·kgf, 7.2 ft·lbf)	
Pivot shaft nut	M12	1	80 Nm (8.0 m·kgf, 58 ft·lbf)	
Rear shock absorber assembly upper nut	M12	1	43 Nm (4.3 m·kgf, 31 ft·lbf)	
Rear shock absorber assembly lower nut	M12	1	59 Nm (5.9 m·kgf, 43 ft·lbf)	
Relay arm and swingarm nut	M12	1	59 Nm (5.9 m·kgf, 43 ft·lbf)	
Relay arm and connecting rod nut	M12	1	59 Nm (5.9 m·kgf, 43 ft·lbf)	
Connecting rod and frame nut	M12	1	59 Nm (5.9 m·kgf, 43 ft·lbf)	
Drive chain guard bolt	M6	3	7 Nm (0.7 m·kgf, 5.1 ft·lbf)	
Drive chain guide bolt	M6	1	7 Nm (0.7 m·kgf, 5.1 ft·lbf)	
Upper bracket pinch bolt	M8	4	23 Nm (2.3 m·kgf, 17 ft·lbf)	
Lower bracket pinch bolt	M8	4	22 Nm (2.2 m·kgf, 16 ft·lbf)	See TIP.
Cap bolt	M37	2	20 Nm (2.0 m·kgf, 14 ft·lbf)	
Damper rod bolt	M12	2	28 Nm (2.8 m·kgf, 20 ft·lbf)	
Speed sensor lead holder bolt	M6	1	7 Nm (0.7 m·kgf, 5.1 ft·lbf)	
Front mudguard bolt (WR125X)	M6	4	7 Nm (0.7 m·kgf, 5.1 ft·lbf)	
Lower handlebar holder nut	M10	2	34 Nm (3.4 m·kgf, 24 ft·lbf)	
Upper bracket stay bolt	M6	2	10 Nm (1.0 m·kgf, 7.2 ft·lbf)	
Steering stem nut	M22	1	140 Nm (14.0 m·kgf, 100 ft·lbf)	
Lower ring nut (initial tightening torque)	M25	1	38 Nm (3.8 m·kgf, 27 ft·lbf)	See TIP.
Lower ring nut (final tightening torque)	M25	1	4 Nm (0.4 m·kgf, 2.9 ft·lbf)	See TIP.
Upper handlebar holder bolt	M8	2	23 Nm (2.3 m·kgf, 17 ft·lbf)	
Front brake master cylinder holder bolt	M6	2	9 Nm (0.9 m·kgf, 6.5 ft·lbf)	
Clutch lever holder bolt	M6	1	9 Nm (0.9 m·kgf, 6.5 ft·lbf)	

Item	Thread size	Q'ty	Tightening torque	Remarks
Clutch lever nut	M6	1	7 Nm (0.7 m·kgf, 5.1 ft·lbf)	
Front brake hose union bolt	M10	2	30 Nm (3.0 m·kgf, 22 ft·lbf)	
Front brake hose holder bolt	M6	2	10 Nm (1.0 m·kgf, 7.2 ft·lbf)	
Fuel tank front bracket and frame bolt	M6	1	10 Nm (1.0 m·kgf, 7.2 ft·lbf)	
Fuel tank rear bracket and frame bolt	M6	2	10 Nm (1.0 m·kgf, 7.2 ft·lbf)	
Fuel tank and fuel tank front bracket bolt	M6	2	7 Nm (0.7 m·kgf, 5.1 ft·lbf)	
Fuel tank and fuel tank rear bracket bolt	M6	2	7 Nm (0.7 m·kgf, 5.1 ft·lbf)	
Fuel pump bolt	M5	6	4 Nm (0.4 m·kgf, 2.9 ft·lbf)	
Rear side cover and seat bolt	M8	2	23 Nm (2.3 m·kgf, 17 ft·lbf)	
Seat bracket bolt	M8	2	23 Nm (2.3 m·kgf, 17 ft·lbf)	
Rear side cover bolt	M6	2	7 Nm (0.7 m·kgf, 5.1 ft·lbf)	
Rear fender bolt	M6	2	7 Nm (0.7 m·kgf, 5.1 ft·lbf)	
Fuel tank cover assembly bolt	M6	12	7 Nm (0.7 m·kgf, 5.1 ft·lbf)	
Rear mudguard bolt	M6	2	7 Nm (0.7 m·kgf, 5.1 ft·lbf)	
Rear frame cover bolt	M6	4	7 Nm (0.7 m·kgf, 5.1 ft·lbf)	
Tail/brake light assembly cover bolt	M6	6	7 Nm (0.7 m·kgf, 5.1 ft·lbf)	
Tail/brake light assembly bolt	M6	4	7 Nm (0.7 m·kgf, 5.1 ft·lbf)	
License plate bracket nut	M6	2	7 Nm (0.7 m·kgf, 5.1 ft·lbf)	
Rear left and right turn signal light nut	M6	2	7 Nm (0.7 m·kgf, 5.1 ft·lbf)	
Battery cover bolt	M6	3	7 Nm (0.7 m·kgf, 5.1 ft·lbf)	
Battery box bolt	M6	4	7 Nm (0.7 m·kgf, 5.1 ft·lbf)	
Battery bracket bolt	M6	1	10 Nm (1.0 m·kgf, 7.2 ft·lbf)	
Front brake disc bolt (WR125R)	M6	6	13 Nm (1.3 m·kgf, 9.4 ft·lbf)	
Front brake disc bolt (WR125X)	M8	6	23 Nm (2.3 m·kgf, 17 ft·lbf)	
Spoke nipple (front and rear wheel)	—	72	3 Nm (0.3 m·kgf, 2.2 ft·lbf)	
Front brake caliper bolt	M8	2	30 Nm (3.0 m·kgf, 22 ft·lbf)	
Front wheel axle	M14	1	58 Nm (5.8 m·kgf, 42 ft·lbf)	
Front wheel axle pinch bolt	M6	2	9 Nm (0.9 m·kgf, 6.5 ft·lbf)	See TIP.
Front brake caliper bleed screw	M8	1	6 Nm (0.6 m·kgf, 4.3 ft·lbf)	
Front brake pad pin	M10	1	18 Nm (1.8 m·kgf, 13 ft·lbf)	
Rear wheel axle nut	M18	1	90 Nm (9.0 m·kgf, 65 ft·lbf)	
Drive chain adjusting locknut	M8	2	16 Nm (1.6 m·kgf, 11 ft·lbf)	
Rear brake disc bolt	M6	6	12 Nm (1.2 m·kgf, 8.7 ft·lbf)	

Item	Thread size	Q'ty	Tightening torque	Remarks
Rear wheel sprocket bolt	M8	6	35 Nm (3.5 m·kgf, 25 ft·lbf)	
Rear brake caliper bleed screw	M8	1	6 Nm (0.6 m·kgf, 4.3 ft·lbf)	
Rear brake pad pin	M8	1	13 Nm (1.3 m·kgf, 9.4 ft·lbf)	
Rider footrest/sidestand bracket assembly bolt	M10	2	62 Nm (6.2 m·kgf, 45 ft·lbf)	
Rider footrest/brake pedal bracket assembly bolt	M10	2	62 Nm (6.2 m·kgf, 45 ft·lbf)	
Passenger footrest bolt (left and right)	M8	4	20 Nm (2.0 m·kgf, 14 ft·lbf)	
Rear brake master cylinder bolt	M6	2	10 Nm (1.0 m·kgf, 7.2 ft·lbf)	
Rear brake master cylinder lock-nut	M8	1	17 Nm (1.7 m·kgf, 12 ft·lbf)	
Rear brake light switch	M10	1	24 Nm (2.4 m·kgf, 17 ft·lbf)	
Rear brake hose union bolt	M10	1	30 Nm (3.0 m·kgf, 22 ft·lbf)	
Brake fluid reservoir bolt	M6	1	4 Nm (0.4 m·kgf, 2.9 ft·lbf)	
Brake fluid reservoir bracket bolt	M6	1	7 Nm (0.7 m·kgf, 5.1 ft·lbf)	
Rear brake hose holder bolt	M8	1	22 Nm (2.2 m·kgf, 16 ft·lbf)	
Sidestand nut	M10	1	55 Nm (5.5 m·kgf, 40 ft·lbf)	
Sidestand switch bolt	M5	2	4 Nm (0.4 m·kgf, 2.9 ft·lbf)	
Brake pedal bolt	M8	1	10 Nm (1.0 m·kgf, 7.2 ft·lbf)	
Front fender bolt	M6	4	7 Nm (0.7 m·kgf, 5.1 ft·lbf)	
Headlight bracket bolt	M6	3	10 Nm (1.0 m·kgf, 7.2 ft·lbf)	
Headlight bracket cover bolt	M6	5	7 Nm (0.7 m·kgf, 5.1 ft·lbf)	
Headlight unit bolt	M6	2	7 Nm (0.7 m·kgf, 5.1 ft·lbf)	
Front turn signal light bolt (left and right)	M6	2	7 Nm (0.7 m·kgf, 5.1 ft·lbf)	
Ignition coil bolt	M6	2	7 Nm (0.7 m·kgf, 5.1 ft·lbf)	
Rectifier/regulator bolt	M6	2	7 Nm (0.7 m·kgf, 5.1 ft·lbf)	
Ground lead bolt (to frame)	M6	1	7 Nm (0.7 m·kgf, 5.1 ft·lbf)	
Horn bolt	M6	1	9 Nm (0.9 m·kgf, 6.5 ft·lbf)	
ECU (engine control unit) bolt	M6	2	7 Nm (0.7 m·kgf, 5.1 ft·lbf)	
Shift pedal bolt	M6	1	16 Nm (1.6 m·kgf, 11 ft·lbf)	

**TIP****Lower ring nut**

1. Tighten the lower ring nut to 38 Nm (3.8 m·kgf, 27 ft·lbf), and then loosen it completely.
2. Retighten the lower ring nut to 4 Nm (0.4 m·kgf, 2.9 ft·lbf).

**TIP****Lower bracket pinch bolt**

Tighten the lower bracket pinch bolts "1" to 22 Nm (2.2 m·kgf, 16 ft·lbf) twice, each time in the order of lower pinch bolt → upper pinch bolt. Do not loosen the bolts after tightening them to specification.

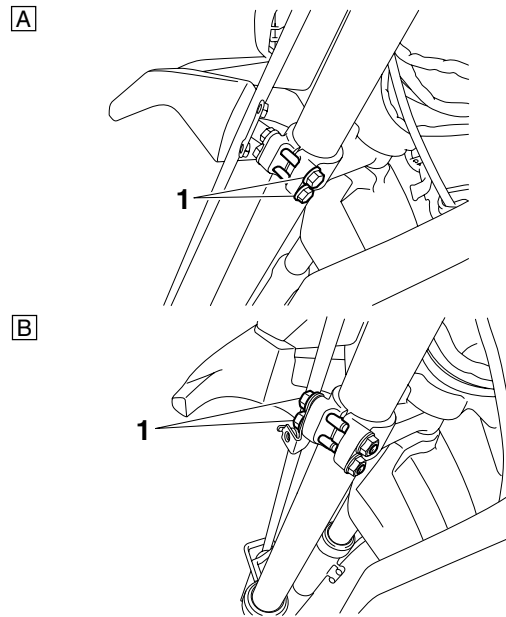

- A. WR125R
- B. WR125X

**TIP****Front wheel axle pinch bolts**

1. Insert the front wheel axle from the right side of the vehicle and tighten it to 58 Nm (5.8 m·kgf, 42 ft·lbf).
2. Tighten each bolt to 9 Nm (0.9 m·kgf, 6.5 ft·lbf) in the order of pinch bolt "2" → pinch bolt "1" → pinch bolt "2" (or pinch bolt "1" → pinch bolt "2" → pinch bolt "1").

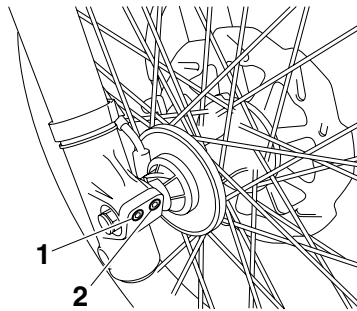

# Yamaha R125 ~~125~~ LUBRICATION POINTS AND LUBRICANT TYPES

EAS20360







## LUBRICATION POINTS AND LUBRICANT TYPES

EAS20370

### ENGINE

Lubrication point	Lubricant
Oil seal lips	
Bearings	
Cylinder head bolt seats, cylinder head bolt threads and washers	
Water pump assembly O-rings	
Cylinder head cover gasket	
Connecting rod big end	
Piston pin	
Cylinder inner surface, piston, ring grooves, and piston rings	
Balancer O-rings	
Camshaft lobes and rocker arm rollers	
Decompression cam	
Valve stems and valve stem seals	
Valve stem ends	
Rocker arm shafts	
Rocker arm inner surface	
Decompression lever pivoting point	
Engine oil drain plug O-ring	
Oil pump driven gear shaft	
Oil filter cover O-ring	
Intake manifold O-ring	
Fuel injector O-ring	
Timing mark accessing screw O-ring	
Crankshaft end accessing screw O-ring	
Engine oil filler cap O-ring	
Starter clutch gear thrust surfaces and washer	
Starter clutch rollers and starter clutch gear boss	
Starter motor O-ring	
Starter clutch idle gear shaft and starter clutch idle gear inner surface	
Starter clutch idle gear thrust surfaces and washer	
Clutch push lever	
Primary driven gear inner surface	
Long clutch push rod ends	
Short clutch push rod and ball	





















# Yamaha R125 LUBRICATION POINTS AND LUBRICANT TYPES

Lubrication point	Lubricant
Clutch boss nut seat, nut thread, and lock washer	
Main axle and pinion gears	
Drive axle and wheel gears	
Shift drum assembly	
Shift forks and shift fork guide bar	
Shift shaft	
Crankshaft position sensor/stator coil lead grommet	Yamaha bond No.1215 (Three Bond No.1215®)
Crankcase mating surfaces	Yamaha bond No.1215 (Three Bond No.1215®)
Timing chain tensioner bolt threads	Yamaha bond No.1215 (Three Bond No.1215®)

# Yamaha R125 LUBRICATION POINTS AND LUBRICANT TYPES

EAS20380

## CHASSIS

Lubrication point	Lubricant
Swingarm dust cover lips	
Swingarm pivot shaft bushing (outer surface) and swingarm bushings (inner surface)	
Pivot shaft	
Oil seal lips (swingarm and connecting rod)	
Swingarm spacer and connecting rod spacer (outer surface)	
Chain tensioner spacers outer surface	
Steering bearings, bearing outer races, and bearing cover lip	
Oil seal lips (front wheel and speed sensor)	
Front wheel axle	
Rear wheel oil seal lips	
Rear wheel axle	
Tube guide (throttle grip) inner surface and throttle cable end	
Clutch lever pivoting point	
Clutch cable end	
Sidestand pivoting point and metal-to-metal moving parts	
Sidestand spring hooks	
Brake pedal pivoting point and metal-to-metal moving parts	
Brake pedal spring hooks	
Passenger footrest pivoting point	
Passenger footrest spring and ball	
Brake lever pivoting point and metal-to-metal moving parts	



# YamahaR125LUBRICATION POINTS AND LUBRICANT TYPES

---

# Yamaha R125 BLOW BY OIL LUBRICATION SYSTEM CHART AND DIAGRAMS

EAS20390

## LUBRICATION SYSTEM CHART AND DIAGRAMS

EAS20400

### ENGINE OIL LUBRICATION CHART

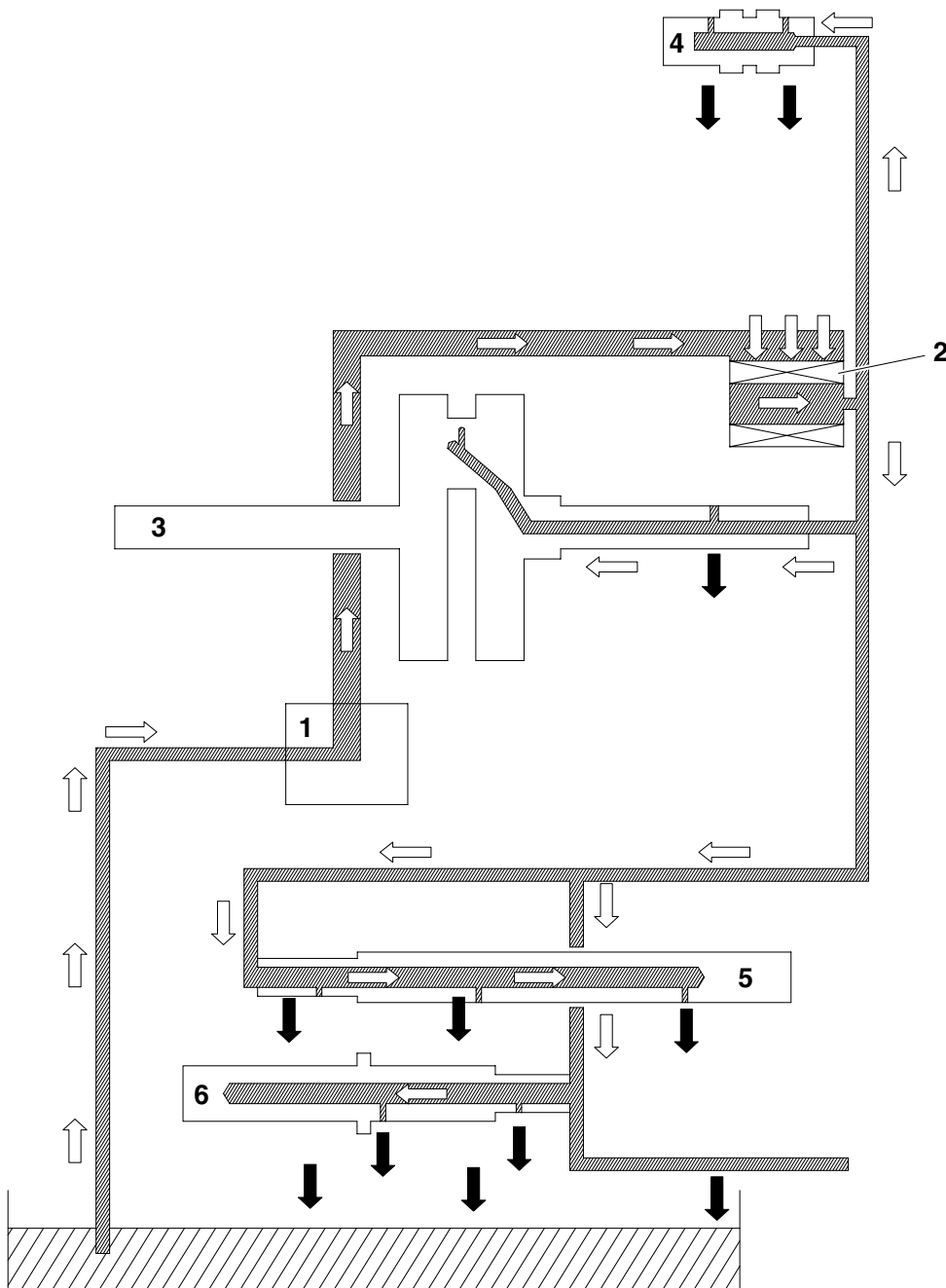

# YamahaR125LCM LUBRICATION SYSTEM CHART AND DIAGRAMS

---

1. Oil pump
2. Oil filter element
3. Crankshaft
4. Camshaft
5. Main axle
6. Drive axle

# Yamaha R125 LUBRICATION SYSTEM CHART AND DIAGRAMS

EAS20410

## LUBRICATION DIAGRAMS

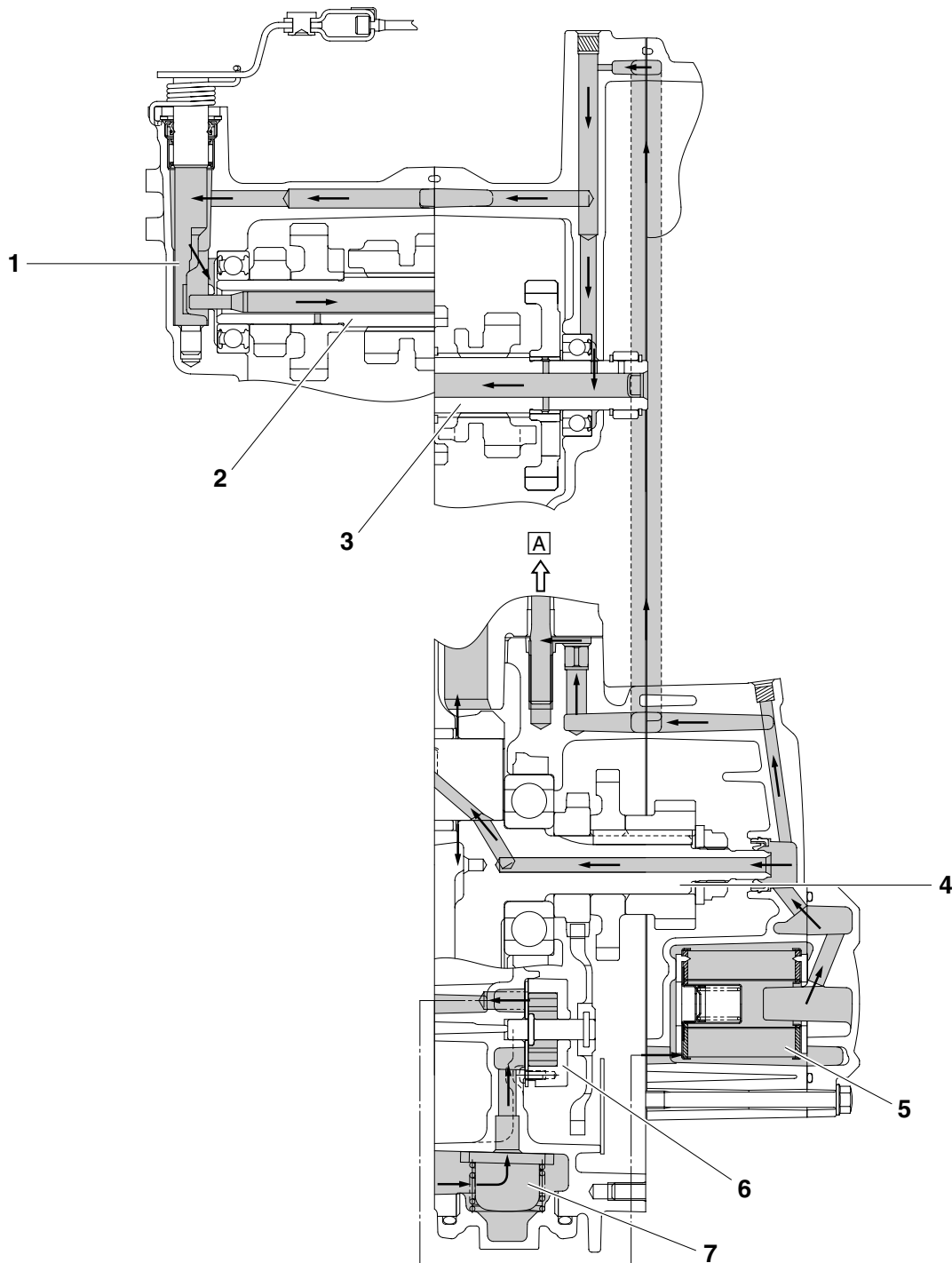

# Yamaha R125 LUBRICATION SYSTEM CHART AND DIAGRAMS

---

1. Clutch push lever
2. Main axle
3. Drive axle
4. Crankshaft
5. Oil filter
6. Oil pump assembly
7. Oil strainer
- A. To cylinder head

# Yamaha R125 2007 FLOW CHART AND DIAGRAMS

---

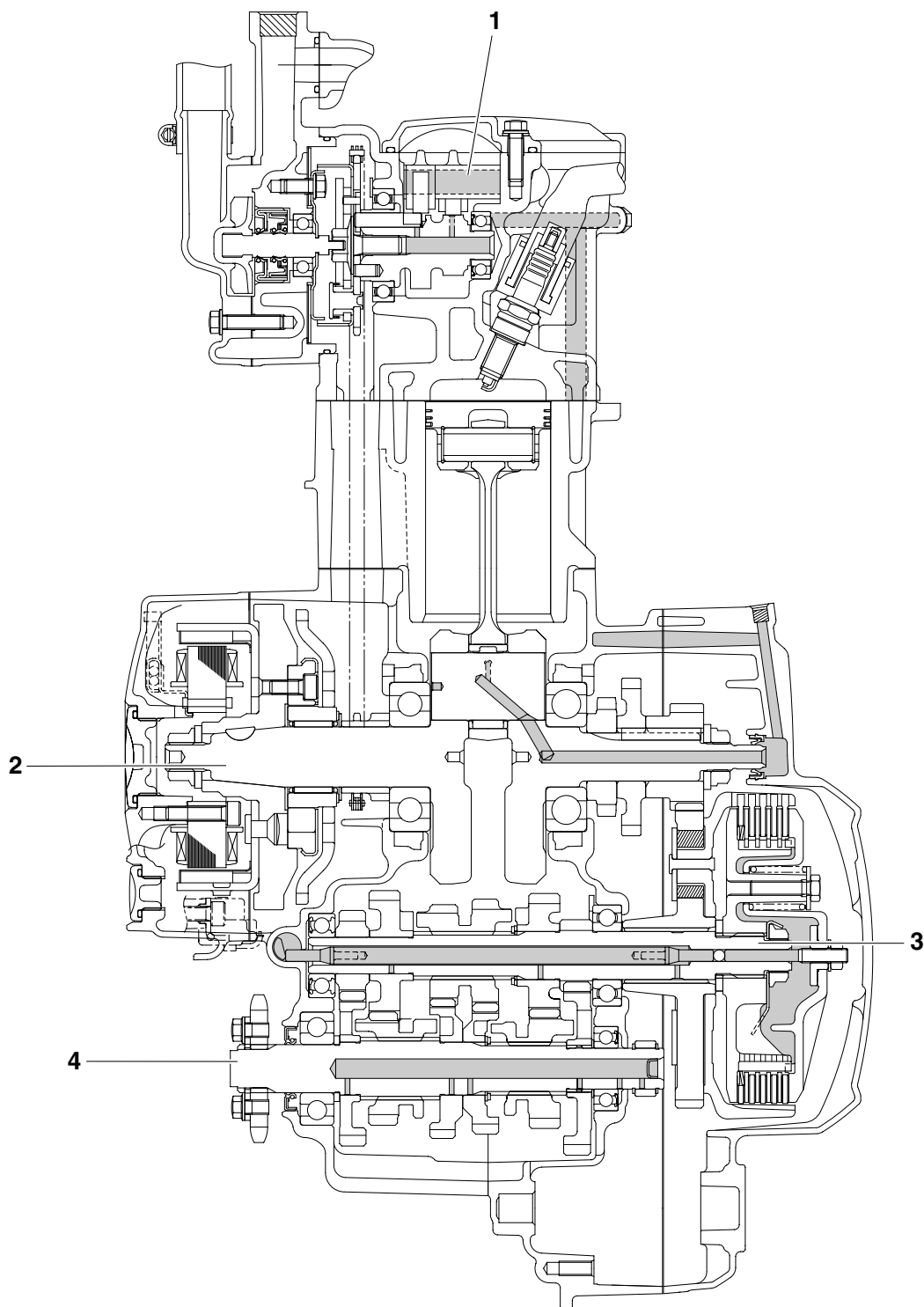

# YamahaR125LCM LUBRICATION SYSTEM CHART AND DIAGRAMS

---

1. Camshaft
2. Crankshaft
3. Main axle
4. Drive axle

EAS20420

COOLING SYSTEM DIAGRAMS

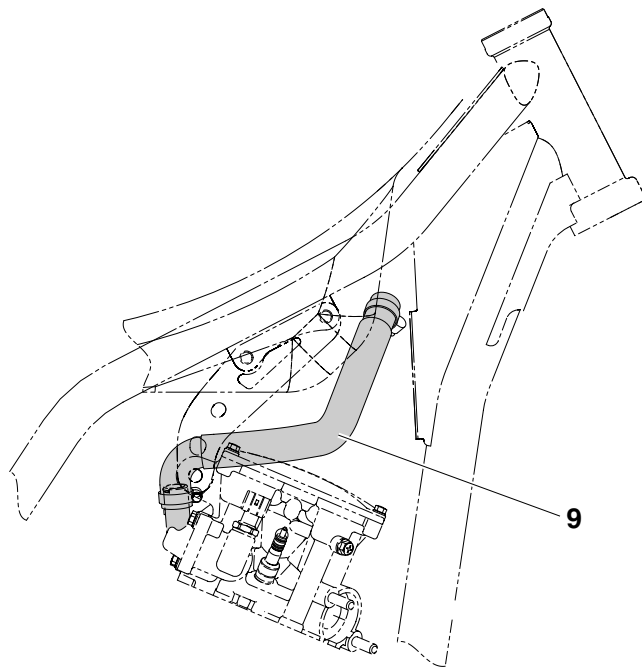
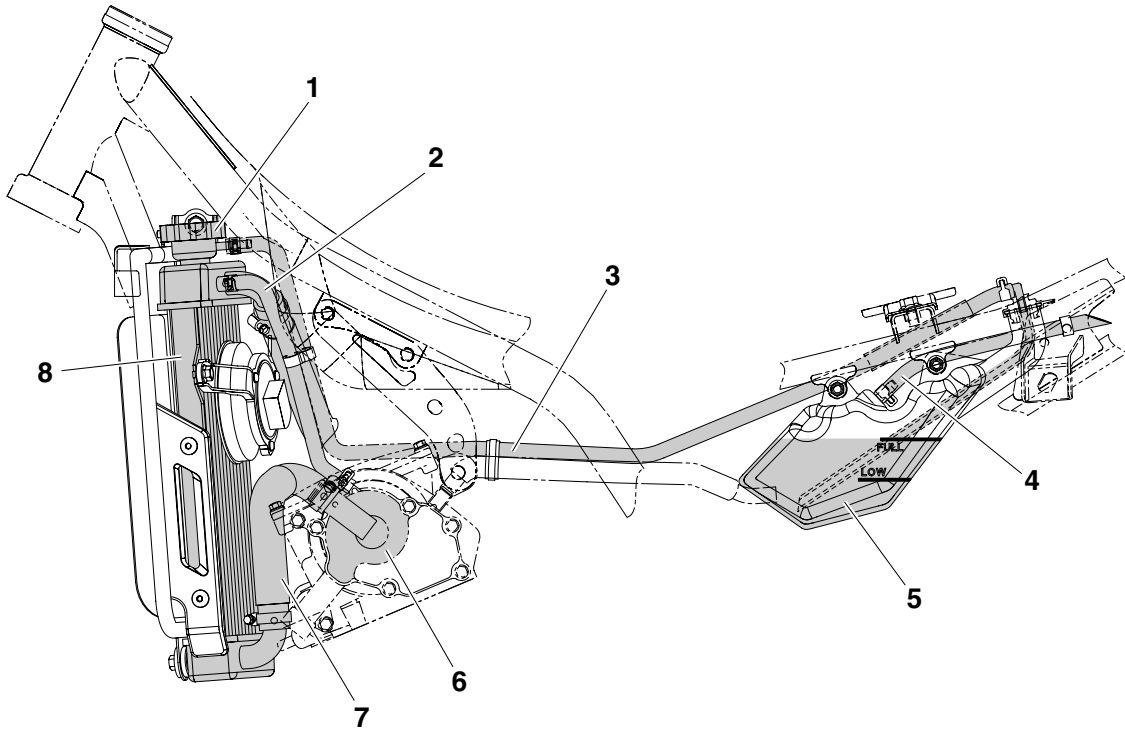



1. Radiator cap
2. Water pump breather hose
3. Coolant reservoir hose
4. Coolant reservoir breather hose
5. Coolant reservoir
6. Water pump
7. Radiator outlet hose
8. Radiator
9. Radiator inlet hose

EAS20430

CABLE ROUTING

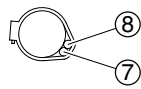
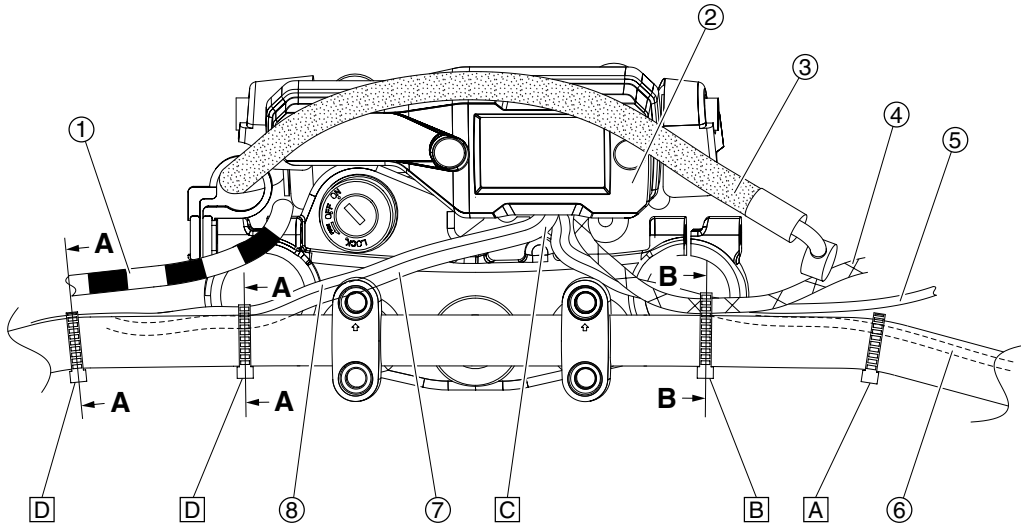

**A-A**

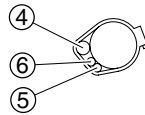

**B-B**

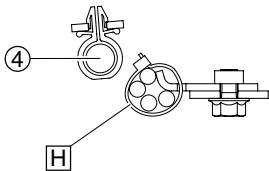
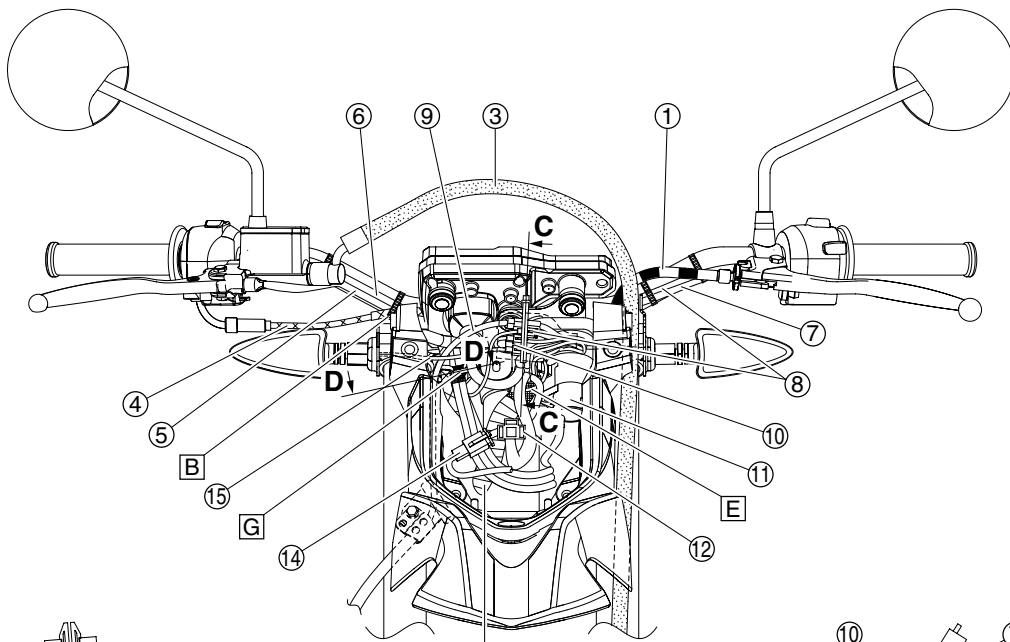

**D-D**

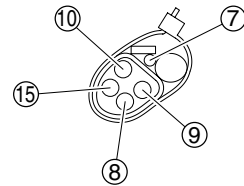

**C-C**

- 
1. Clutch cable
  2. Meter assembly
  3. Front brake hose
  4. Throttle cable
  5. Front brake light switch lead
  6. Right handlebar switch lead
  7. Left handlebar switch lead
  8. Clutch switch lead
  9. Speed sensor lead
  10. Front left turn signal lead
  11. Main switch
  12. Headlight coupler
  13. Wire harness
  14. Auxiliary light coupler
  15. Front right turn signal lead
- A. Fasten the front brake light switch lead with the plastic band at the bend in the handlebar.
  - B. Fasten the right handlebar switch lead and front brake light switch lead with the plastic band at the bend in the handlebar.
  - C. Route the right handlebar switch lead, left handlebar switch lead, clutch switch lead, front brake light switch lead, and throttle cable between the meter assembly and the upper bracket.
  - D. Fasten the left handlebar switch lead and clutch switch lead with the plastic bands at the bend in the handlebar.
  - E. Fasten the wire harness at the white tape with a plastic locking tie.
  - F. Route the wire harness to the rear of the front brake light switch lead, left handlebar switch lead, and right handlebar switch lead.
  - G. Fasten the left handlebar switch lead, right handlebar switch lead, clutch switch lead, and front brake light switch lead at the white tape on each lead with a plastic locking tie.
  - H. Fasten the left handlebar switch lead, right handlebar switch lead, clutch switch lead, and front brake light switch lead to the upper bracket stay with a plastic locking tie.

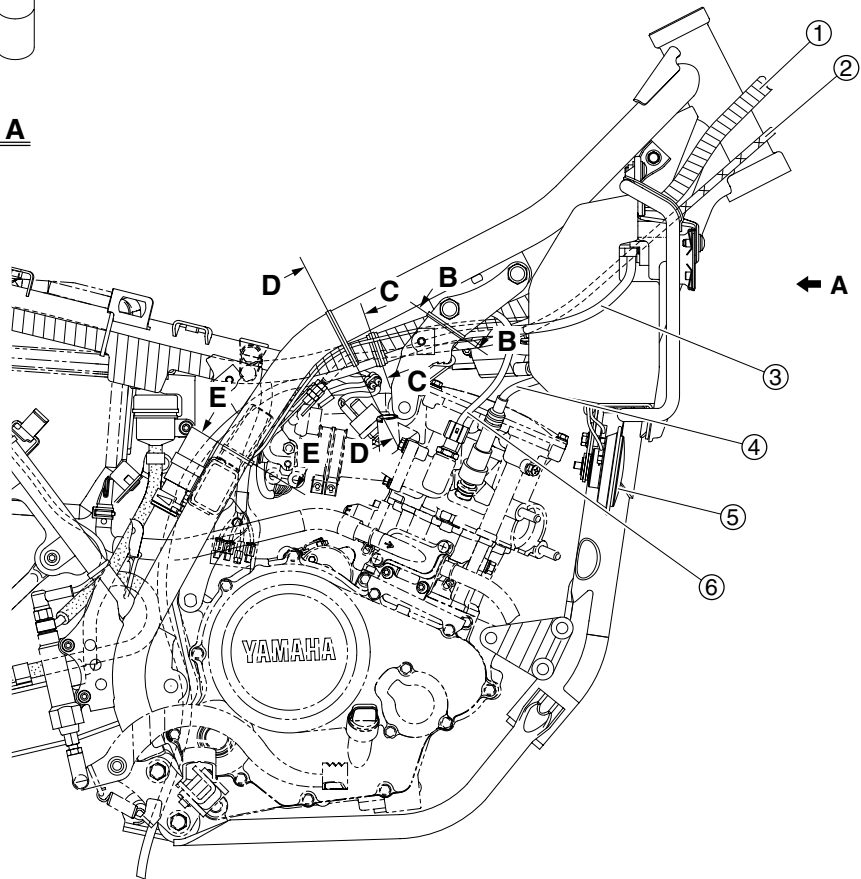
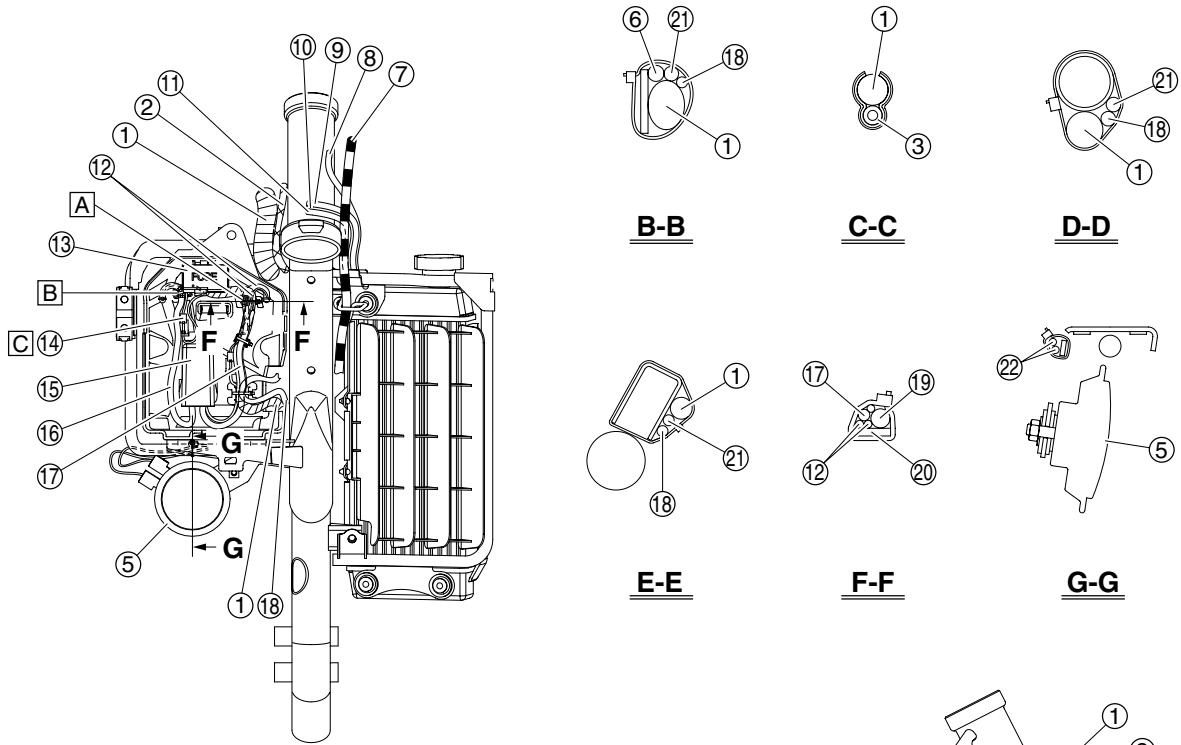

1. Wire harness
  2. Throttle cable
  3. Battery breather hose
  4. Spark plug lead
  5. Horn
  6. Coolant temperature sensor lead
  7. Clutch cable
  8. Main switch lead
  9. Right handlebar switch lead
  10. Front brake light switch lead
  11. Left handlebar switch lead
  12. Negative battery lead
  13. Fuse box
  14. Coupler (starter relay to fuse box)
  15. Starter relay
  16. Positive battery lead
  17. Starter relay lead
  18. Ground lead
  19. Fuse box lead
  20. Battery box
  21. Starter motor lead
  22. Horn leads
- A. Fasten the starter relay lead at the white tape with a plastic locking tie.
  - B. Fasten the positive battery lead at the white tape with a plastic locking tie.
  - C. Position the coupler (starter relay to fuse box) to the rear of the positive battery lead.

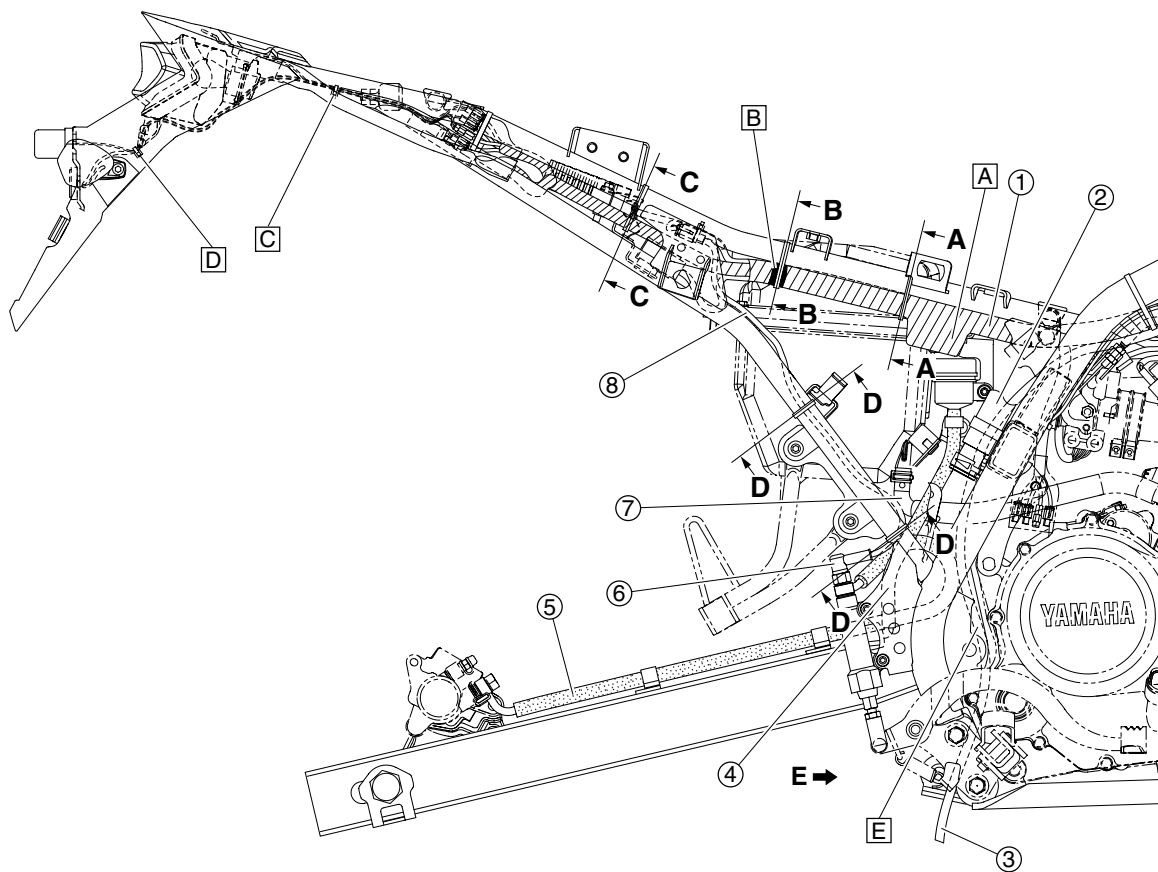
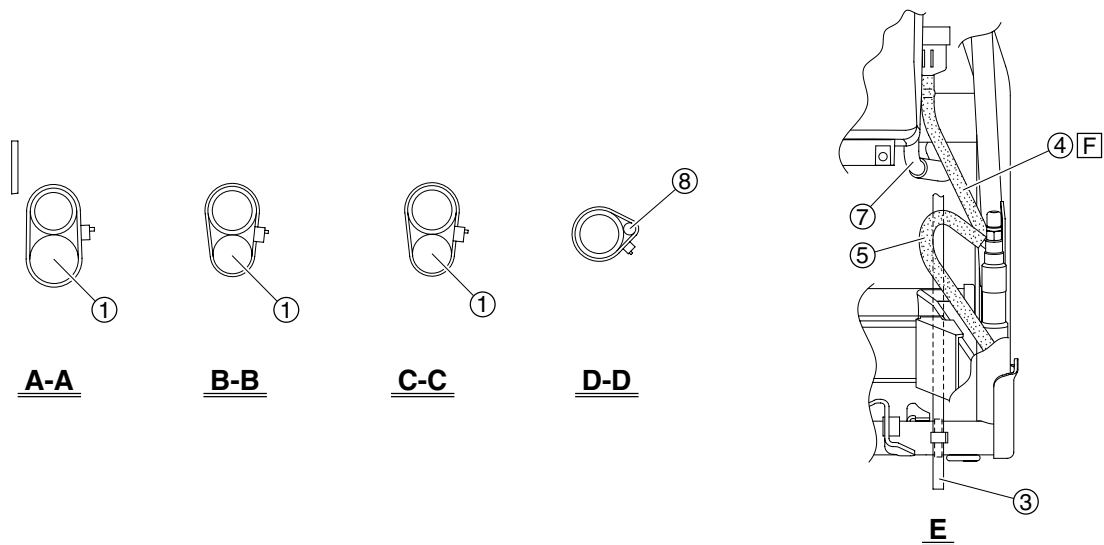

- 
1. Wire harness
  2. Air filter case silencer hose
  3. Battery breather hose
  4. Brake fluid reservoir hose
  5. Rear brake hose
  6. Rear brake light switch
  7. Air induction system hose (air filter case to reed valve assembly)
  8. Rear brake light switch lead
  - A. Route the wire harness so that the diode is positioned under the harness.
  - B. Fasten the wire harness at the white tape with a plastic locking tie.
  - C. Fasten the rear left turn signal light lead, rear right turn signal light lead, license plate light lead, and tail/brake light lead with a plastic locking tie.
  - D. Fasten the rear left turn signal light lead, rear right turn signal light lead, and license plate light lead with a plastic locking tie.
  - E. Route the battery breather hose between the crankcase and the swingarm.
  - F. Route the brake fluid reservoir hose to the inside of the frame, and to the outside of the rear brake hose and air induction system hose (air filter case to reed valve assembly).

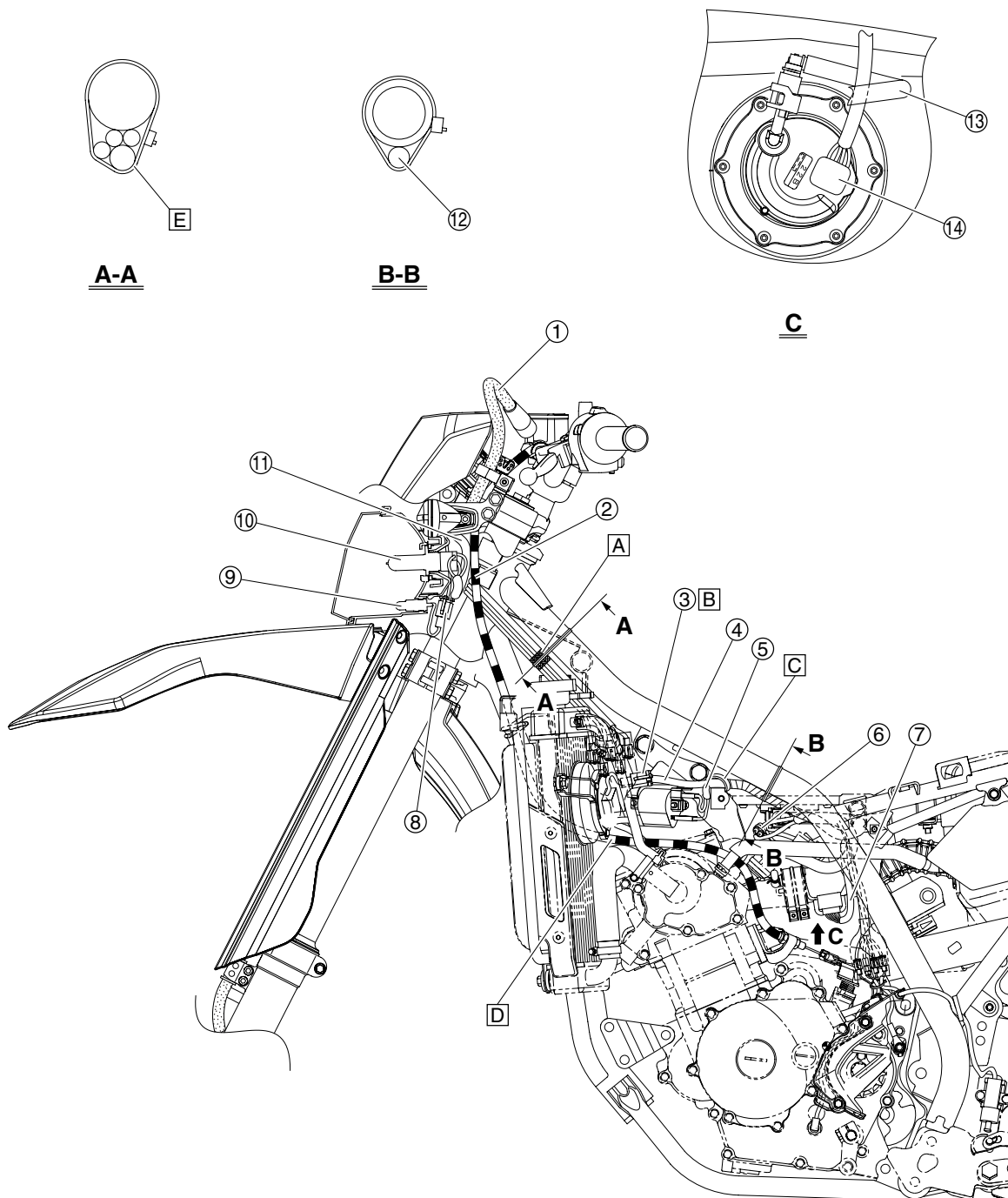



1. Front brake hose
  2. Clutch cable
  3. Radiator fan motor coupler
  4. Radiator fan motor lead
  5. Ignition coil lead
  6. Fuel injector coupler
  7. Throttle body sensor assembly coupler
  8. Auxiliary light coupler
  9. Auxiliary light bulb
  10. Headlight bulb
  11. Headlight lead
  12. Wire harness
  13. Fuel hose
  14. Fuel pump coupler
- A. Fasten the left handlebar switch lead, right handlebar switch lead, main switch lead, and front brake light switch lead at the white tape on each lead with a plastic locking tie.
  - B. Fasten the radiator fan motor coupler to the engine bracket (front left upper) with a plastic locking tie.
  - C. Fasten the wire harness at the split in the harness to the engine bracket (front left upper) with a plastic locking tie.
  - D. Route the clutch cable under the spark plug lead.
  - E. Fasten the left handlebar switch lead, right handlebar switch lead, main switch lead, and front brake light switch lead with a plastic locking tie.

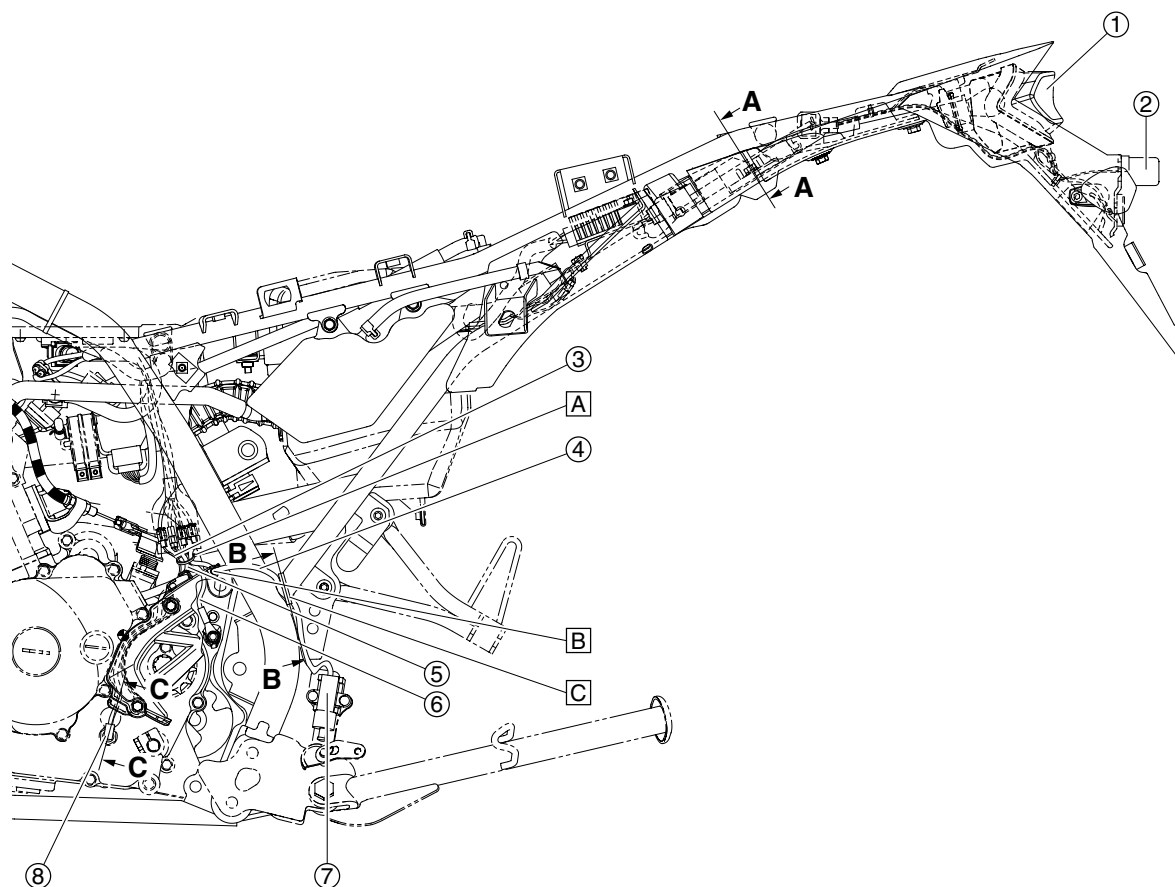
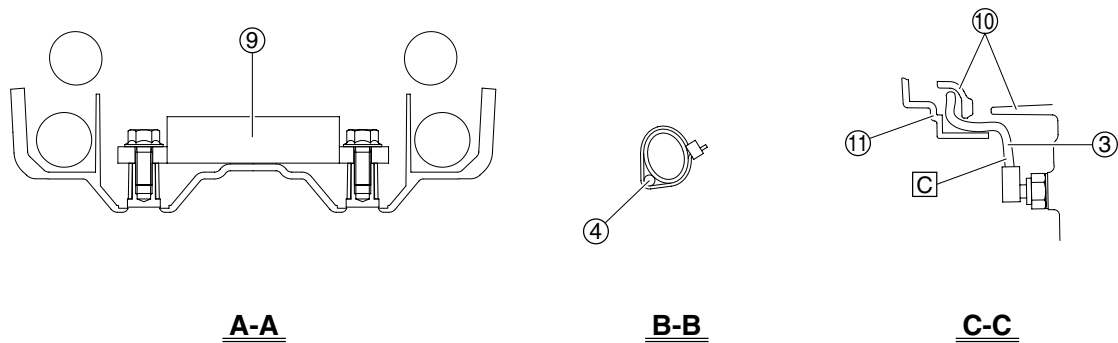

1. Tail/brake light
  2. License plate light
  3. Neutral switch lead
  4. Sidestand switch lead
  5. Crankshaft position sensor/stator coil lead
  6. Ground lead
  7. Sidestand switch
  8. Neutral switch
  9. ECU (engine control unit)
  10. Generator cover
  11. Drive sprocket cover
- A. Fasten the neutral switch lead, crankshaft position sensor/stator coil lead, sidestand switch lead, and ground lead with a plastic locking tie.
  - B. Fasten the sidestand switch lead with the holder on the drive sprocket cover.
  - C. Fasten the sidestand switch lead at the white tape to the frame with plastic locking tie.
  - D. Route the neutral switch lead between the generator cover and the drive sprocket cover.

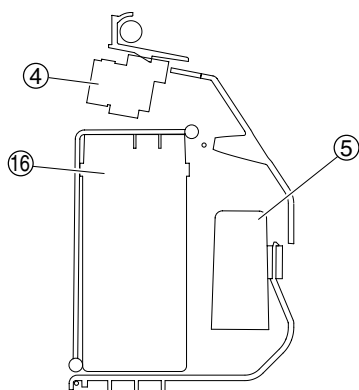

A-A

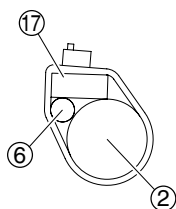

B-B

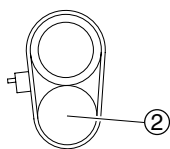

C-C

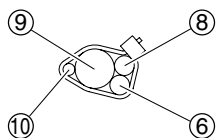

D-D

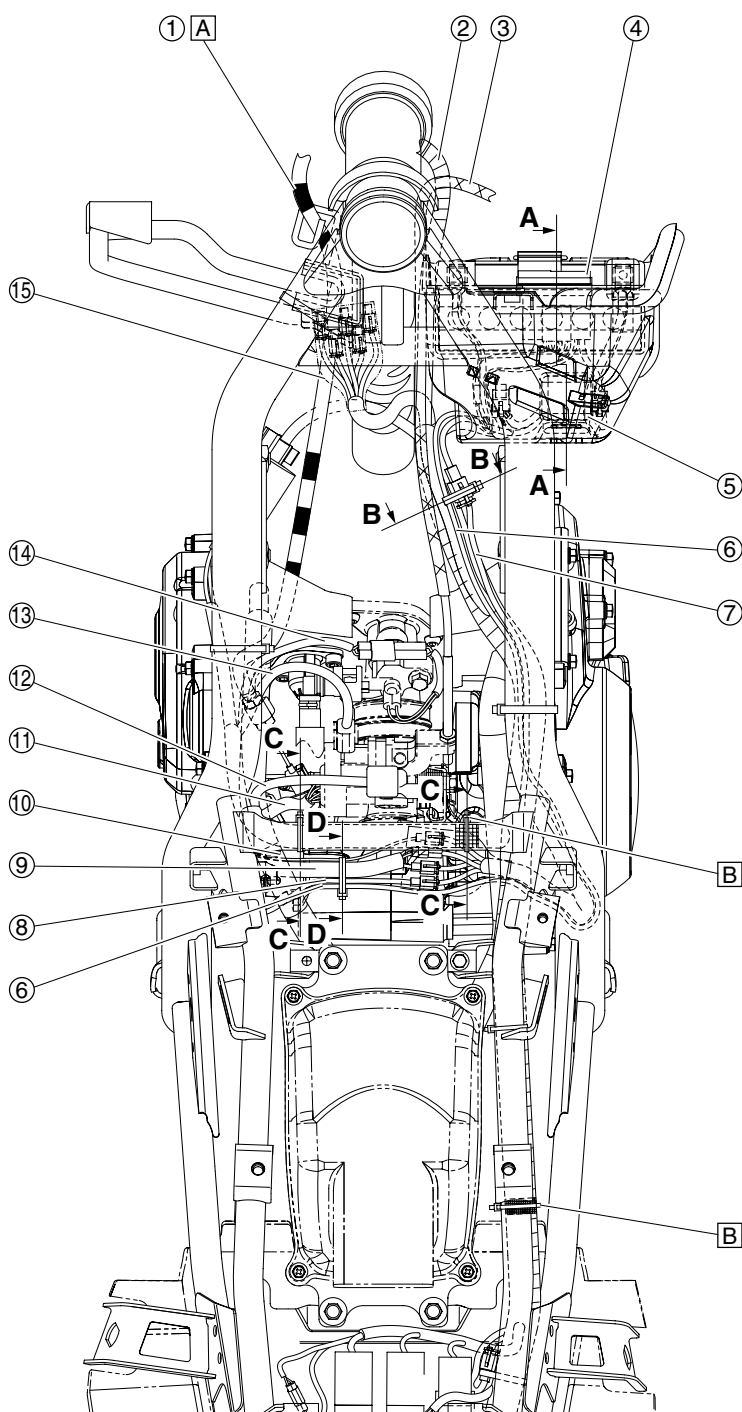

1. Clutch cable
  2. Wire harness
  3. Throttle cable
  4. Fuse box
  5. Starter relay
  6. Ground lead
  7. Starter motor lead
  8. Sidestand switch lead
  9. Crankshaft position sensor/stator coil lead
  10. Neutral switch lead
  11. Throttle body sensor assembly lead
  12. Fuel pump lead
  13. FID (fast idle solenoid) lead
  14. Fuel injector lead
  15. Couplers (left handlebar switch, right handlebar switch, main switch, and front brake light switch)
  16. Battery
  17. Starter motor coupler
- A. Route the clutch cable between the radiator and frame, and pass the cable through the cable guide.
  - B. Fasten the wire harness at the white tape with a plastic locking tie.

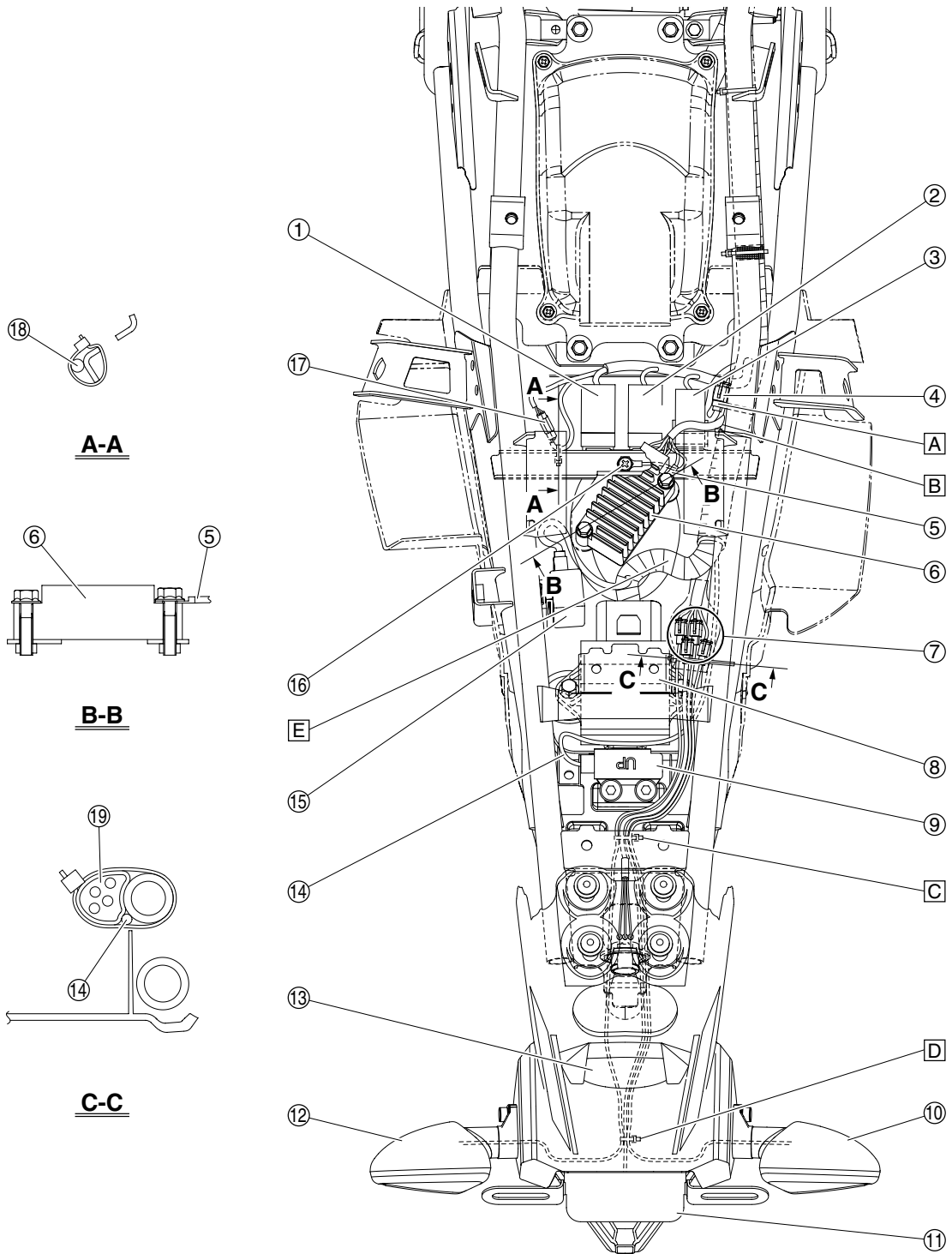

- 
1. Headlight relay
  2. Radiator fan motor relay
  3. Starting circuit cut-off relay
  4. Rear brake light switch coupler
  5. Ground lead (short lead to the frame)
  6. Rectifier/regulator
  7. Couplers (tail/brake light, license plate light, rear left turn signal light, and rear right turn signal light)
  8. ECU (engine control unit)
  9. Lean angle sensor
  10. Rear right turn signal light
  11. License plate light
  12. Rear left turn signal light
  13. Tail/brake light
  14. Lean angle sensor lead
  15. Turn signal relay
  16. Ground lead (long lead to the frame)
  17. Self-diagnosis signal coupler
  18. Self-diagnosis signal lead
  19. Tail/brake light lead, license plate light lead, rear left turn signal light lead, and rear right turn signal light lead
- A. Fasten the rear brake light switch coupler and the leads that branch off from the wire harness with a plastic locking tie.
  - B. Route the leads that branch off from the wire harness along the frame, and then fasten them with a plastic locking tie.
  - C. Fasten the rear left turn signal light lead, rear right turn signal light lead, license plate light lead, and tail/brake light lead with a plastic locking tie.
  - D. Fasten the rear left turn signal light lead, rear right turn signal light lead, and license plate light lead with a plastic locking tie.
  - E. Route the wire harness under the rectifier/regulator bracket.

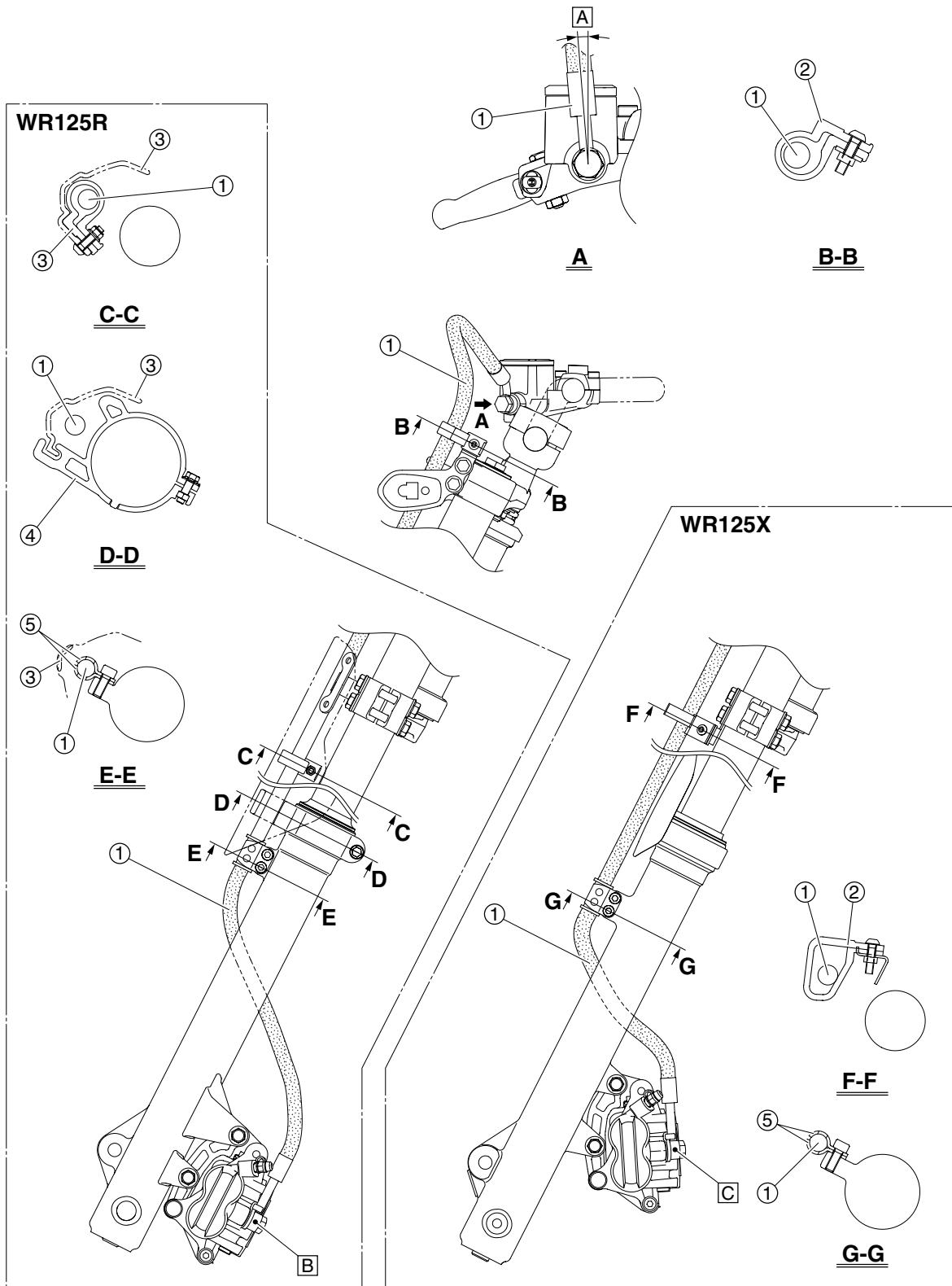



1. Front brake hose
2. Front brake hose guide
3. Front fork protector
4. Front fork protector guide
5. Front brake hose holders
  - A. 4–6°
  - B. White paint mark
  - C. Yellow paint mark

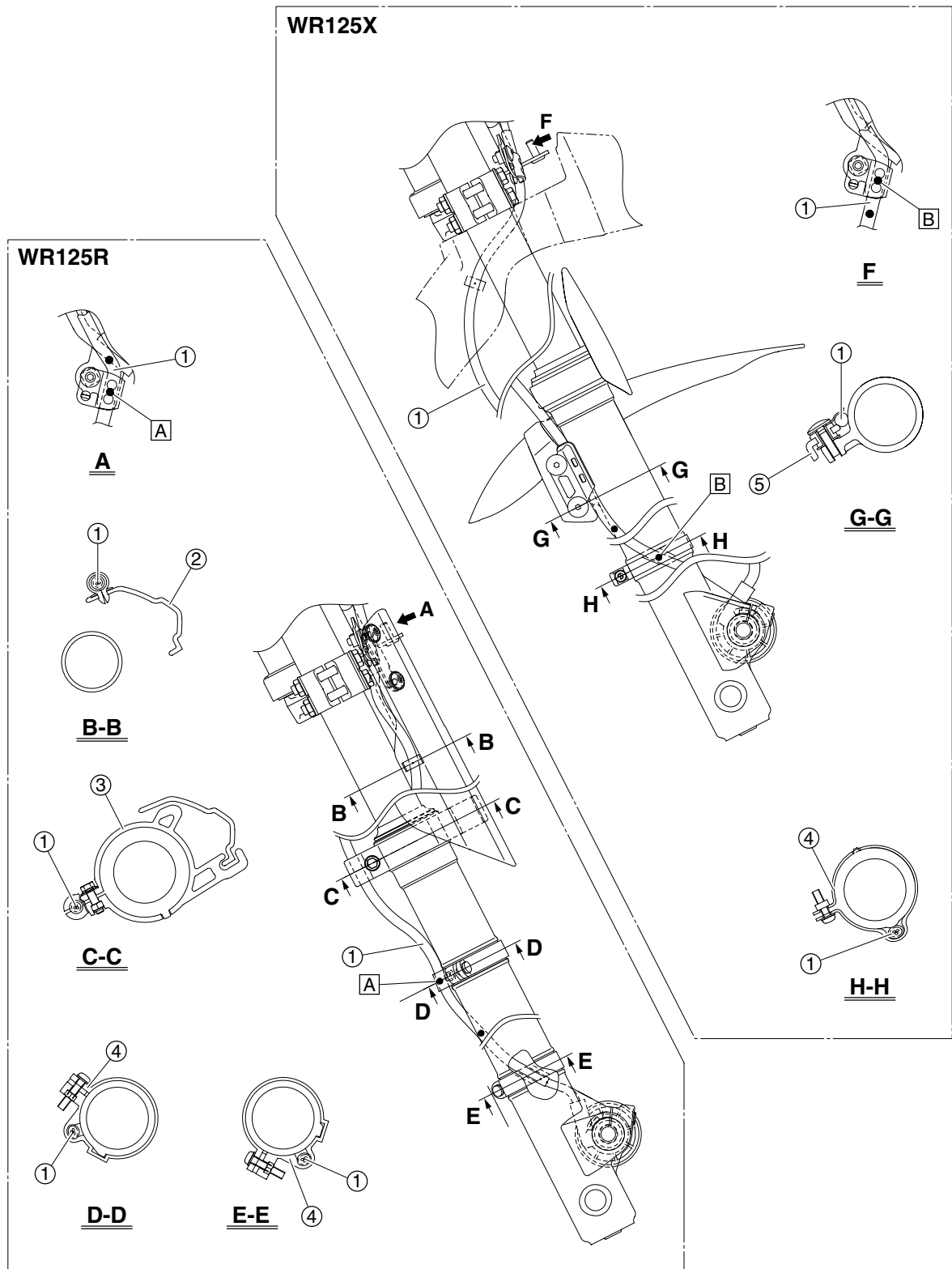

1. Speed sensor lead
  2. Front fork protector
  3. Front fork protector guide
  4. Speed sensor lead holder
  5. Front mudguard
- A. White paint mark
  - B. Yellow paint mark



---

## PERIODIC CHECKS AND ADJUSTMENTS

<b>PERIODIC MAINTENANCE</b> .....	3-1
INTRODUCTION .....	3-1
PERIODIC MAINTENANCE CHART FOR THE EMISSION CONTROL SYSTEM .....	3-1
GENERAL MAINTENANCE AND LUBRICATION CHART .....	3-1
<b>ENGINE</b> .....	3-4
ADJUSTING THE VALVE CLEARANCE .....	3-4
ADJUSTING THE EXHAUST GAS VOLUME .....	3-5
ADJUSTING THE ENGINE IDLING SPEED .....	3-6
ADJUSTING THE THROTTLE CABLE FREE PLAY .....	3-6
CHECKING THE SPARK PLUG .....	3-7
CHECKING THE IGNITION TIMING .....	3-8
MEASURING THE COMPRESSION PRESSURE .....	3-9
CHECKING THE ENGINE OIL LEVEL .....	3-10
CHANGING THE ENGINE OIL .....	3-10
ADJUSTING THE CLUTCH CABLE FREE PLAY .....	3-12
CLEANING THE AIR FILTER ELEMENT .....	3-12
CHECKING THE THROTTLE BODY JOINT AND AIR FILTER CASE JOINT .....	3-13
CHECKING THE FUEL LINE .....	3-13
CHECKING THE CYLINDER HEAD BREATHER HOSE .....	3-13
CHECKING THE EXHAUST SYSTEM .....	3-14
CHECKING THE COOLANT LEVEL .....	3-14
CHECKING THE COOLING SYSTEM .....	3-14
CHANGING THE COOLANT .....	3-15
<b>CHASSIS</b> .....	3-17
ADJUSTING THE REAR DISC BRAKE .....	3-17
CHECKING THE BRAKE FLUID LEVEL .....	3-17
CHECKING THE FRONT BRAKE PADS .....	3-18
CHECKING THE REAR BRAKE PADS .....	3-18
CHECKING THE FRONT BRAKE HOSE .....	3-18
CHECKING THE REAR BRAKE HOSE .....	3-19
BLEEDING THE HYDRAULIC BRAKE SYSTEM .....	3-19
ADJUSTING THE DRIVE CHAIN SLACK .....	3-20
LUBRICATING THE DRIVE CHAIN .....	3-21
CHECKING AND ADJUSTING THE STEERING HEAD .....	3-21
CHECKING THE FRONT FORK .....	3-22
ADJUSTING THE REAR SHOCK ABSORBER ASSEMBLY .....	3-22
CHECKING THE TIRES .....	3-23
CHECKING THE WHEELS .....	3-25
CHECKING AND TIGHTENING THE SPOKES .....	3-25
CHECKING AND LUBRICATING THE CABLES .....	3-26
LUBRICATING THE CLUTCH LEVER .....	3-26
LUBRICATING THE BRAKE LEVER .....	3-26
LUBRICATING THE BRAKE PEDAL .....	3-26
LUBRICATING THE SIDESTAND .....	3-26
LUBRICATING THE REAR SUSPENSION .....	3-26

<b>ELECTRICAL SYSTEM</b> .....	3-27
CHECKING AND CHARGING THE BATTERY .....	3-27
CHECKING THE FUSES .....	3-27
REPLACING THE HEADLIGHT BULB.....	3-27
ADJUSTING THE HEADLIGHT BEAM .....	3-27

YamahaR125.COM

---

EAS20450

## PERIODIC MAINTENANCE

EAS20460

### INTRODUCTION

This chapter includes all information necessary to perform recommended checks and adjustments. If followed, these preventive maintenance procedures will ensure more reliable vehicle operation, a longer service life and reduce the need for costly overhaul work. This information applies to vehicles already in service as well as to new vehicles that are being prepared for sale. All service technicians should be familiar with this entire chapter.

EAU46920

### PERIODIC MAINTENANCE CHART FOR THE EMISSION CONTROL SYSTEM

#### TIP

- The annual checks must be performed every year, except if a kilometer-based maintenance, or for the UK, a mileage-based maintenance, is performed instead.
- From 30000 km (17500 mi), repeat the maintenance intervals starting from 6000 km (3500 mi).
- Items marked with an asterisk should be performed by a Yamaha dealer as they require special tools, data and technical skills.

NO.	ITEM	CHECK OR MAINTENANCE JOB	ODOMETER READING					ANNUAL CHECK
			1000 km (600 mi)	6000 km (3500 mi)	12000 km (7000 mi)	18000 km (10500 mi)	24000 km (14000 mi)	
1	* Fuel line	• Check fuel hoses for cracks or damage.		√	√	√	√	√
2	Spark plug	• Check condition. • Clean and regap.		√		√		
		• Replace.			√		√	
3	* Valves	• Check valve clearance. • Adjust.		√	√	√	√	
4	* Fuel injection	• Adjust engine idling speed.	√	√	√	√	√	√
5	* Muffler and exhaust pipe	• Check the screw clamp(s) for looseness.	√	√	√	√	√	

EAU17716

### GENERAL MAINTENANCE AND LUBRICATION CHART

#### TIP

- The annual checks must be performed every year, except if a kilometer-based maintenance, or for the UK, a mileage-based maintenance, is performed instead.
- From 30000 km (17500 mi), repeat the maintenance intervals starting from 6000 km (3500 mi).
- Items marked with an asterisk should be performed by a Yamaha dealer as they require special tools, data and technical skills.

NO.	ITEM	CHECK OR MAINTENANCE JOB	ODOMETER READING					ANNUAL CHECK
			1000 km (600 mi)	6000 km (3500 mi)	12000 km (7000 mi)	18000 km (10500 mi)	24000 km (14000 mi)	
1	* Air filter element	• Clean.		√		√		
		• Replace.			√		√	
2	* Battery	• Check electrolyte level and specific gravity. • Make sure that the breather hose is properly routed.		√	√	√	√	√
3	Clutch	• Check operation. • Adjust.	√	√	√	√	√	
4	* Front brake	• Check operation, fluid level and vehicle for fluid leakage.	√	√	√	√	√	√
		• Replace brake pads.	Whenever worn to the limit					
5	* Rear brake	• Check operation, fluid level and vehicle for fluid leakage.	√	√	√	√	√	√
		• Replace brake pads.	Whenever worn to the limit					



NO.	ITEM	CHECK OR MAINTENANCE JOB	ODOMETER READING					ANNUAL CHECK	
			1000 km (600 mi)	6000 km (3500 mi)	12000 km (7000 mi)	18000 km (10500 mi)	24000 km (14000 mi)		
6	* Brake hoses	<ul style="list-style-type: none"> <li>• Check for cracks or damage.</li> <li>• Replace.</li> </ul>		√	√	√	√	√	
			Every 4 years						
7	* Wheels	<ul style="list-style-type: none"> <li>• Check runout, spoke tightness and for damage.</li> <li>• Tighten spokes if necessary.</li> </ul>		√	√	√	√		
8	* Tires	<ul style="list-style-type: none"> <li>• Check tread depth and for damage.</li> <li>• Replace if necessary.</li> <li>• Check air pressure.</li> <li>• Correct if necessary.</li> </ul>		√	√	√	√	√	
9	* Wheel bearings	<ul style="list-style-type: none"> <li>• Check bearing for looseness or damage.</li> </ul>		√	√	√	√		
10	* Swingarm	<ul style="list-style-type: none"> <li>• Check operation and for excessive play.</li> <li>• Lubricate with lithium-soap-based grease.</li> </ul>		√	√	√	√		
			Every 24000 km (14000 mi)						
11	Drive chain	<ul style="list-style-type: none"> <li>• Check chain slack, alignment and condition.</li> <li>• Adjust and lubricate chain with a special O-ring chain lubricant thoroughly.</li> </ul>	Every 500 km (300 mi) and after washing the motorcycle or riding in the rain						
12	* Steering bearings	<ul style="list-style-type: none"> <li>• Check bearing play and steering for roughness.</li> <li>• Lubricate with lithium-soap-based grease.</li> </ul>	√	√	√	√	√		
			Every 24000 km (14000 mi)						
13	* Chassis fasteners	<ul style="list-style-type: none"> <li>• Make sure that all nuts, bolts and screws are properly tightened.</li> </ul>		√	√	√	√	√	
14	Brake lever pivot shaft	<ul style="list-style-type: none"> <li>• Lubricate with silicone grease.</li> </ul>		√	√	√	√	√	
15	Brake pedal pivot shaft	<ul style="list-style-type: none"> <li>• Lubricate with lithium-soap-based grease.</li> </ul>		√	√	√	√	√	
16	Clutch lever pivot shaft	<ul style="list-style-type: none"> <li>• Lubricate with lithium-soap-based grease.</li> </ul>		√	√	√	√	√	
17	Sidestand	<ul style="list-style-type: none"> <li>• Check operation.</li> <li>• Lubricate.</li> </ul>		√	√	√	√	√	
18	* Sidestand switch	<ul style="list-style-type: none"> <li>• Check operation.</li> </ul>	√	√	√	√	√	√	
19	* Front fork	<ul style="list-style-type: none"> <li>• Check operation and for oil leakage.</li> </ul>		√	√	√	√		
20	* Shock absorber assembly	<ul style="list-style-type: none"> <li>• Check operation and shock absorber for oil leakage.</li> </ul>		√	√	√	√		
21	* Rear suspension relay arm and connecting arm pivoting points	<ul style="list-style-type: none"> <li>• Check operation.</li> <li>• Lubricate with lithium-soap-based grease.</li> </ul>		√	√	√	√		
22	Engine oil	<ul style="list-style-type: none"> <li>• Change.</li> <li>• Check oil level and vehicle for oil leakage.</li> </ul>	√	When the oil change indicator flashes [2000 km (1200 mi) after the initial 1000 km (600 mi) and every 3000 km (1800 mi) thereafter]					
			Every 3000 km (1800 mi)					√	
23	Engine oil filter element	<ul style="list-style-type: none"> <li>• Replace.</li> </ul>	√	√	√	√	√		
24	* Cooling system	<ul style="list-style-type: none"> <li>• Check coolant level and vehicle for coolant leakage.</li> <li>• Change.</li> </ul>		√	√	√	√	√	
			Every 3 years						
25	* Front and rear brake switches	<ul style="list-style-type: none"> <li>• Check operation.</li> </ul>	√	√	√	√	√	√	
26	Moving parts and cables	<ul style="list-style-type: none"> <li>• Lubricate.</li> </ul>		√	√	√	√	√	
27	* Throttle grip housing and cable	<ul style="list-style-type: none"> <li>• Check operation and free play.</li> <li>• Adjust the throttle cable free play if necessary.</li> <li>• Lubricate the throttle grip housing and cable.</li> </ul>		√	√	√	√	√	
28	* Lights, signals and switches	<ul style="list-style-type: none"> <li>• Check operation.</li> <li>• Adjust headlight beam.</li> </ul>	√	√	√	√	√	√	

EAUM2070

### TIP

---

- The air filter needs more frequent service if you are riding in unusually wet or dusty areas.
  - Hydraulic brake service
    - Regularly check and, if necessary, correct the brake fluid level.
    - Every two years change the brake fluid.
    - Replace the brake hoses every four years and if cracked or damaged.
-

EAS20472

## ENGINE

EAS20520

### ADJUSTING THE VALVE CLEARANCE

The following procedure applies to all of the valves.

#### TIP

- Valve clearance adjustment should be made on a cold engine, at room temperature.
- When the valve clearance is to be measured or adjusted, the piston must be at top dead center (TDC) on the compression stroke.

1. Remove:
  - Fuel tank cover assembly  
Refer to "GENERAL CHASSIS" on page 4-1.
  - Fuel tank  
Refer to "FUEL TANK" on page 7-1.
2. Disconnect:
  - Spark plug cap
3. Remove:
  - Spark plug
  - Cylinder head cover
  - Cylinder head cover gasket  
Refer to "CYLINDER HEAD" on page 5-7.
4. Remove:
  - Timing mark accessing screw "1"
  - Crankshaft end accessing screw "2"

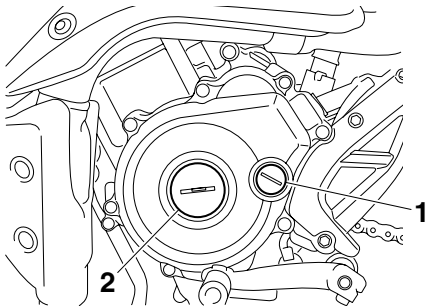

5. Measure:
  - Valve clearance  
Out of specification → Adjust.

	<b>Valve clearance (cold)</b>
	<b>Intake</b> 0.10–0.14 mm (0.0039–0.0055 in)
	<b>Exhaust</b> 0.20–0.24 mm (0.0079–0.0094 in)

- Turn the crankshaft counterclockwise.
- Align the TDC mark "a" on the generator rotor with the stationary pointer "b" on the generator cover.

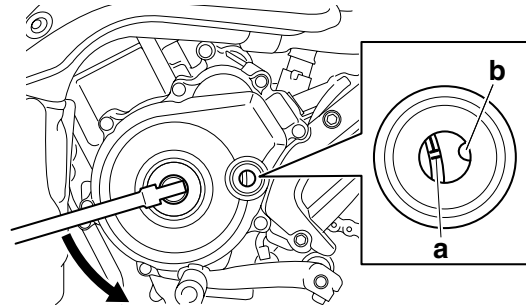

- Check that the cam lobes are positioned as shown in the illustration.

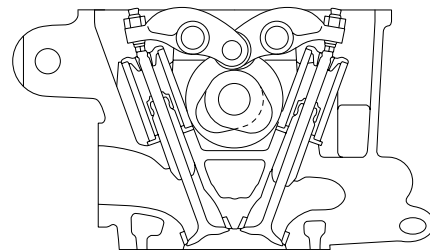

- Measure the valve clearance with a thickness gauge "1".  
Out of specification → Adjust.

	<b>Thickness gauge</b> 90890-03180
	<b>Feeler gauge set</b> YU-26900-9

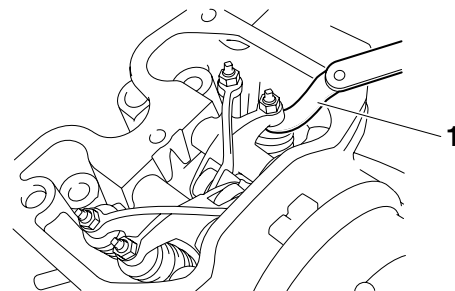

- Adjust:
  - Valve clearance
  - Loosen the locknut "1".
  - Insert a thickness gauge "2" between the end of the adjusting screw and the valve tip.

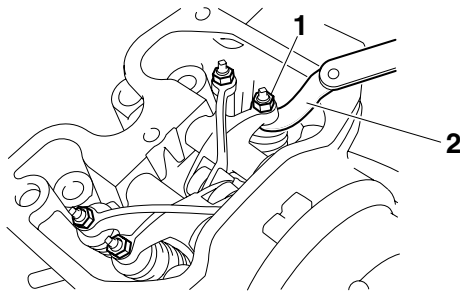

c. Turn the adjusting screw "3" in direction "a" or "b" until the specified valve clearance is obtained.

**Direction "a"**  
Valve clearance is increased.  
**Direction "b"**  
Valve clearance is decreased.

**Tappet adjusting tool**  
**90890-01311**  
**Six piece tappet set**  
**YM-A5970**

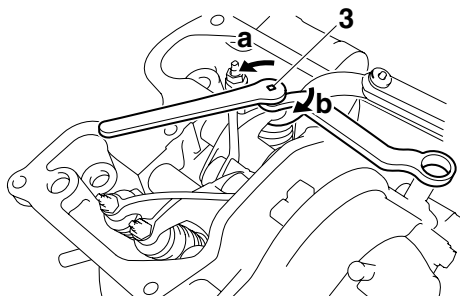

d. Hold the adjusting screw to prevent it from moving and tighten the locknut to specification.

**Valve adjusting screw locknut**  
**7 Nm (0.7 m·kgf, 5.1 ft·lbf)**

e. Measure the valve clearance again.  
f. If the valve clearance is still out of specification, repeat all of the valve clearance adjustment steps until the specified clearance is obtained.



7. Install:  
• All removed parts

**TIP** \_\_\_\_\_  
For installation, reverse the removal procedure.

EAS20600

### ADJUSTING THE EXHAUST GAS VOLUME

**TIP** \_\_\_\_\_

Be sure to set the CO density level to standard, and then adjust the exhaust gas volume.

1. Remove:
  - Seat  
Refer to "GENERAL CHASSIS" on page 4-1.
2. Set the main switch to "OFF".
3. Disconnect:
  - Self-diagnosis signal coupler "1"
4. Connect:
  - FI diagnostic tool "2"

**FI diagnostic tool**  
**90890-03182**

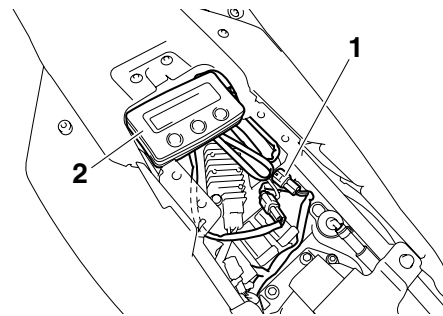

5. While pressing the "MODE" button "1", turn the main switch to "ON".

**TIP** \_\_\_\_\_

- "DIAG" appears on the LCD "2" of the FI diagnostic tool.
- "POWER" LED (Green) "3" comes on.

6. Press the "UP" button "4" to select the CO adjustment mode "CO" or the diagnostic mode "DIAG".

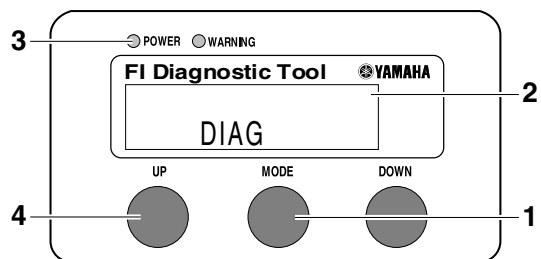

7. After selecting "CO", press the "MODE" button.
8. Check that "C1" appears on the LCD of the FI diagnostic tool, and then press the "MODE" button.
9. Start the engine.

ECA22B1001

**NOTICE**

**Perform the adjustment after the battery has been sufficiently charged.**

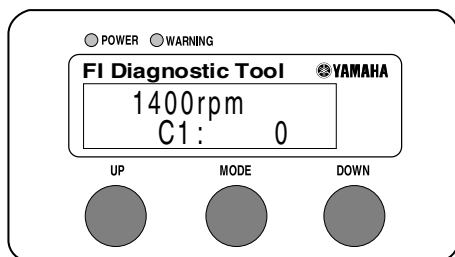

10. Change the CO adjustment volume by pressing the "UP" and "DOWN" buttons.

**TIP**

The CO adjustment volume and engine idling speed appears on the LCD of the FI diagnostic tool.

- To decrease the CO adjustment volume, press the "DOWN" button.
- To increase the CO adjustment volume, press the "UP" button.

11. Release the "DOWN" and "UP" buttons to execute the selection.
12. Set the main switch to "OFF" to cancel the mode.
13. Disconnect:
  - FI diagnostic tool
14. Connect:
  - Self-diagnosis signal coupler
15. Install:
  - Seat
 Refer to "GENERAL CHASSIS" on page 4-1.

EAS20610

**ADJUSTING THE ENGINE IDLING SPEED**

**TIP**

Prior to adjusting the engine idling speed, the air filter element should be clean, and the engine should have adequate compression.

1. Start the engine and let it warm up for several minutes.
2. Connect:
  - Digital tachometer (onto the spark plug lead)
3. Check:
  - Engine idling speed
 Out of specification → Adjust.

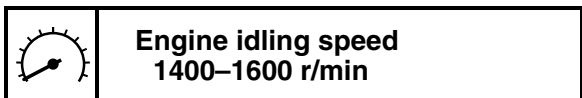

4. Adjust:
  - Engine idling speed

- a. Turn the pilot screw "1" in direction "a" or "b" until the specified engine idling speed is obtained.

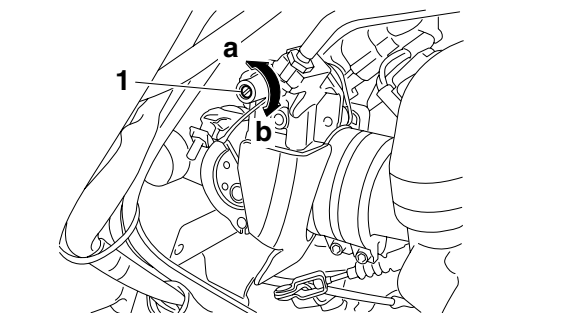
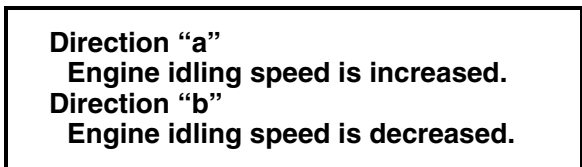

5. Remove:
  - Digital tachometer
6. Adjust:
  - Throttle cable free play
 Refer to "ADJUSTING THE THROTTLE CABLE FREE PLAY" on page 3-6.

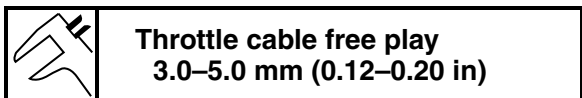

EAS20660

**ADJUSTING THE THROTTLE CABLE FREE PLAY**

**TIP**

Prior to adjusting the throttle cable free play, the engine idling speed should be adjusted.



4. Check:

- Electrode "1"  
Damage/wear → Replace the spark plug.
- Insulator "2"  
Abnormal color → Replace the spark plug.  
Normal color is medium-to-light tan.

5. Clean:

- Spark plug  
(with a spark plug cleaner or wire brush)

6. Measure:

- Spark plug gap "a"  
(with a wire thickness gauge)  
Out of specification → Regap.

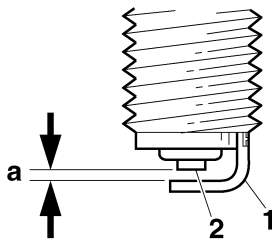
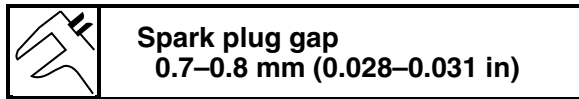

7. Install:

- Spark plug

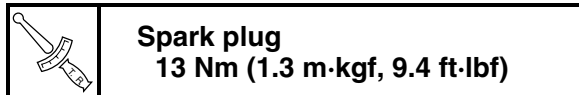

**TIP**

Before installing the spark plug, clean the spark plug and gasket surface.

8. Connect:

- Spark plug cap

EAS20700

### CHECKING THE IGNITION TIMING

**TIP**

Prior to checking the ignition timing, check the wiring connections of the entire ignition system. Make sure all connections are tight and free of corrosion.

1. Remove:

- Timing mark accessing screw "1"

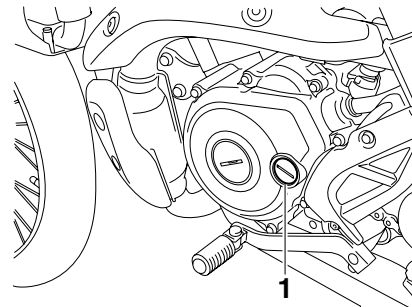

2. Connect:

- Timing light "1"
- Digital tachometer

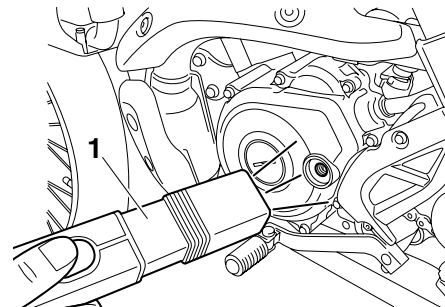
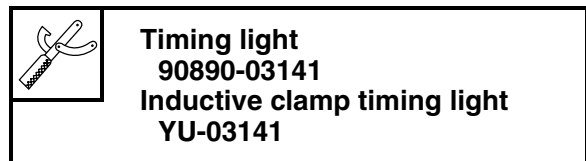

3. Check:

- Ignition timing



- a. Start the engine, warm it up for several minutes, and then let it run at the specified engine idling speed.

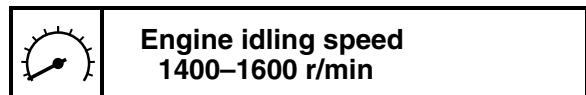

- b. Check that the stationary pointer "a" on the generator cover is within the firing range "b" on the generator rotor.  
Incorrect firing range → Check the ignition system.

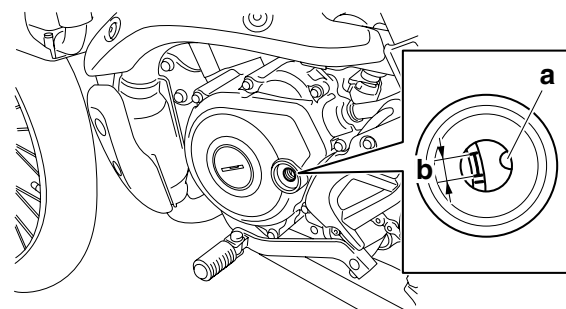

**TIP**

The ignition timing is not adjustable.

4. Remove:

- Digital tachometer
- Timing light

5. Install:

- Timing mark accessing screw  
(along with the O-ring **New**)

EAS20710

**MEASURING THE COMPRESSION PRESSURE**

**TIP**

Insufficient compression pressure will result in a loss of performance.

1. Measure:

- Valve clearance  
Out of specification → Adjust.  
Refer to “ADJUSTING THE VALVE CLEARANCE” on page 3-4.

2. Start the engine, warm it up for several minutes, and then turn it off.

3. Disconnect:

- Spark plug cap

4. Remove:

- Spark plug

ECA13330

**NOTICE**

**Before removing the spark plug, blow away any dirt accumulated in the spark plug well with compressed air to prevent it from falling into the cylinder.**

5. Install:

- Extension “1”
- Compression gauge “2”

	<p><b>Extension</b> 90890-04082</p> <p><b>Compression gauge</b> 90890-03081</p> <p><b>Engine compression tester</b> YU-33223</p>
---	--

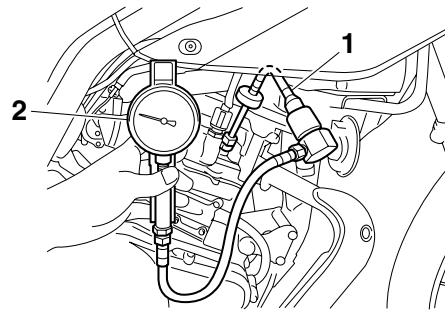

6. Measure:

- Compression pressure  
Out of specification → Refer to steps (c) and (d).

	<p><b>Standard compression pressure (at sea level)</b> 550 kPa/600 r/min (5.5 kgf/cm<sup>2</sup>/600 r/min, 78.2 psi/600 r/min)</p> <p><b>Minimum–maximum</b> 480–620 kPa (4.8–6.2 kgf/cm<sup>2</sup>, 68.3–88.2 psi)</p>
---	---



- Set the main switch to “ON”.
- With the throttle wide open, crank the engine until the reading on the compression gauge stabilizes.
- If the compression pressure is above the maximum specification, check the cylinder head, valve surfaces and piston crown for carbon deposits.  
Carbon deposits → Eliminate.
- If the compression pressure is below the minimum specification, pour a teaspoonful of engine oil into the spark plug bore and measure again.  
Refer to the following table.

Compression pressure (with oil applied into the cylinder)	
Reading	Diagnosis
Higher than without oil	Piston ring(s) wear or damage → Repair.
Same as without oil	Piston, valves, cylinder head gasket or piston ring(s) possibly defective → Repair.



7. Remove:

- Extension
- Compression gauge



8. Install:
- Spark plug

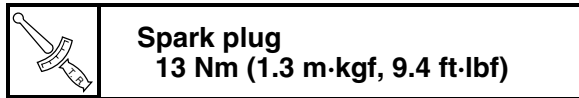

9. Connect:
- Spark plug cap

EAS28920

### CHECKING THE ENGINE OIL LEVEL

1. Stand the vehicle on a level surface.

#### TIP

- Place the vehicle on a suitable stand.
- Make sure the vehicle is upright.

2. Start the engine, warm it up for several minutes, and then turn it off.

3. Check:

- Engine oil level

The engine oil level should be between the minimum level mark “a” and maximum level mark “b”.

Below the minimum level mark → Add the recommended engine oil to the proper level.

#### TIP

- Before checking the engine oil level, wait a few minutes until the oil has settled.
- Do not screw the engine oil filler cap (dipstick) “1” in when checking the oil level.

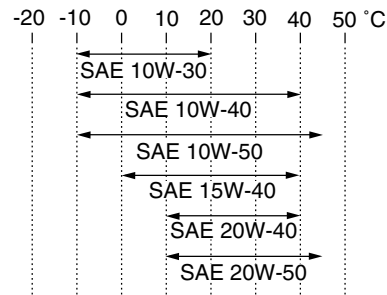
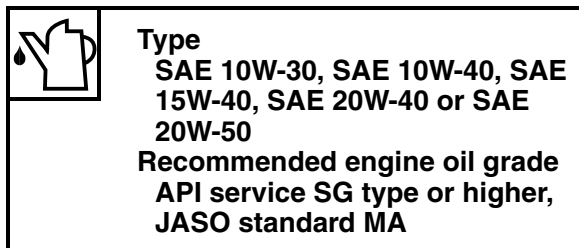
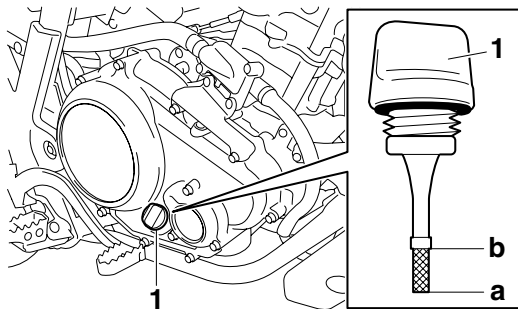

ECA22B1020

#### NOTICE

- Engine oil also lubricates the clutch and the wrong oil types or additives could cause clutch slippage. Therefore, do not add any chemical additives or use engine oils with a grade of “CD” “c” or higher and do not use oils labeled “ENERGY CONSERVING II” “d”.
- Do not allow foreign materials to enter the crankcase.

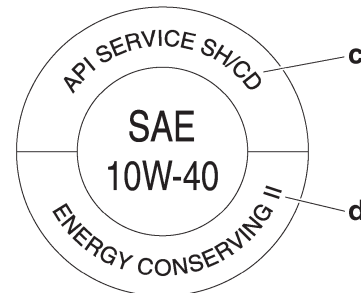

4. Start the engine, warm it up for several minutes, and then turn it off.
5. Check the engine oil level again.

#### TIP

Before checking the engine oil level, wait a few minutes until the oil has settled.

EAS20810

### CHANGING THE ENGINE OIL

1. Start the engine, warm it up for several minutes, and then turn it off.
2. Place a container under the engine oil drain plug.
3. Remove:
  - Engine oil filler cap (dipstick) “1”
  - Engine oil drain plug “2”
  - O-ring “3”
  - Spring “4”
  - Engine oil strainer “5”

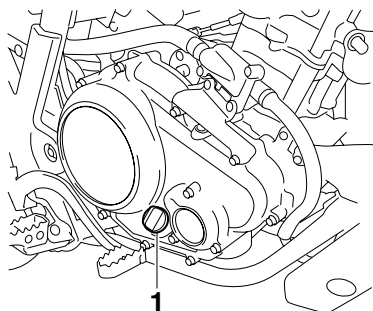

- O-ring **New**
- Engine oil drain plug



**Engine oil drain plug**  
**32 Nm (3.2 m·kgf, 23 ft·lbf)**

8. Fill:
  - Crankcase  
 (with the specified amount of the recommended engine oil)



**Engine oil quantity**  
**Total amount**  
**1.15 L (1.22 US qt, 1.01 Imp.qt)**  
**Without oil filter element replacement**  
**0.95 L (1.00 US qt, 0.84 Imp.qt)**  
**With oil filter element replacement**  
**1.00 L (1.06 US qt, 0.88 Imp.qt)**

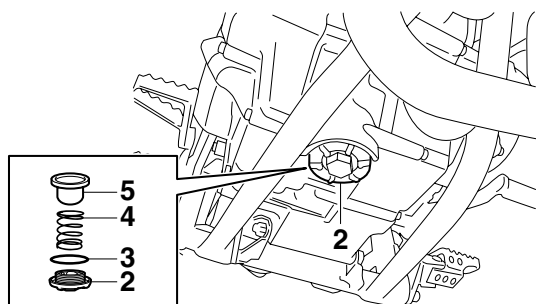

4. Drain:
  - Engine oil  
 (completely from the crankcase)
5. If the oil filter element is also to be replaced, perform the following procedure.

- a. Remove the oil filter element cover “1” and oil filter element “2”.
- b. Install a new O-ring “3”.

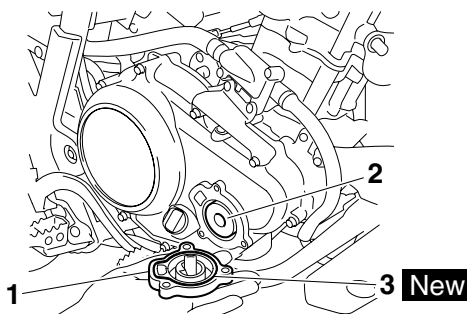

- c. Install the new oil filter element and the oil filter element cover.



**Oil filter element cover bolt**  
**10 Nm (1.0 m·kgf, 7.2 ft·lbf)**

6. Check:
  - Engine oil strainer  
 Dirt → Clean.
7. Install:
  - Engine oil strainer
  - Spring

9. Install:
  - Engine oil filler cap (dipstick)
10. Start the engine, warm it up for several minutes, and then turn it off.
11. Check:
  - Engine  
 (for engine oil leaks)
12. Check:
  - Engine oil level  
 Refer to “CHECKING THE ENGINE OIL LEVEL” on page 3-10.
13. Check:
  - Engine oil pressure

- a. Slightly loosen the oil check bolt “1”.

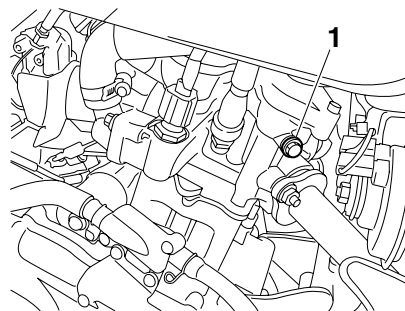

- b. Start the engine and keep it idling until engine oil starts to seep from the oil check bolt. If no engine oil comes out after one minute, turn the engine off so that it will not seize.
- c. Check the engine oil passages, the oil filter element and the oil pump for damage or leakage. Refer to “OIL PUMP” on page 5-47.

- d. Start the engine after solving the problem(s) and check the engine oil pressure again.
- e. Tighten the oil check bolt to specification.

	<b>Oil check bolt</b> <b>7 Nm (0.7 m·kgf, 5.1 ft·lbf)</b>
---	--



EAS20870

### ADJUSTING THE CLUTCH CABLE FREE PLAY

1. Check:
  - Clutch cable free play “a”  
Out of specification → Adjust.

	<b>Clutch lever free play</b> <b>10.0–15.0 mm (0.39–0.59 in)</b>
---	---

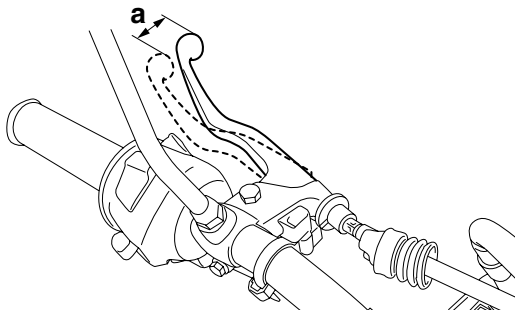

2. Adjust:
  - Clutch cable free play

### Handlebar end

- a. Pull back the rubber cover “1”.
- b. Loosen the locknut “2”.
- c. Turn the adjusting bolt “3” in direction “a” or “b” until the specified clutch cable free play is obtained.

<b>Direction “a”</b> <b>Clutch cable free play is increased.</b> <b>Direction “b”</b> <b>Clutch cable free play is decreased.</b>
--

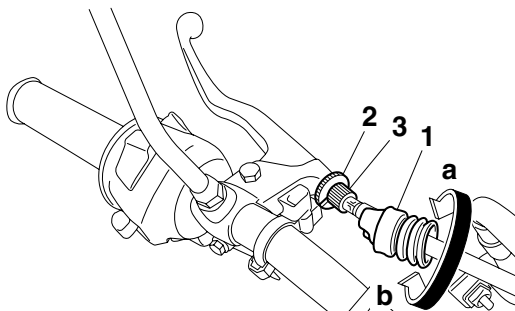

- d. Tighten the locknut.
- e. Place the rubber cover in its original position.

**TIP** \_\_\_\_\_  
 If the specified clutch cable free play cannot be obtained on the handlebar end of the cable, use the adjusting nut on the engine end.



### Engine end

- a. Loosen the locknut “1”.
- b. Turn the adjusting nut “2” in direction “a” or “b” until the specified clutch cable free play is obtained.

<b>Direction “a”</b> <b>Clutch cable free play is increased.</b> <b>Direction “b”</b> <b>Clutch cable free play is decreased.</b>
--

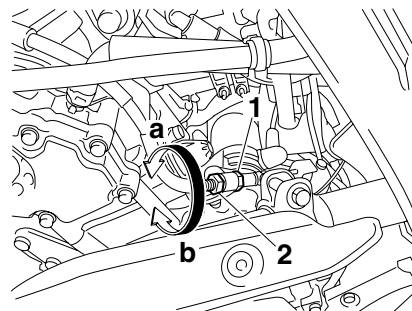

- c. Tighten the locknut.

	<b>Locknut</b> <b>7 Nm (0.7 m·kgf, 5.1 ft·lbf)</b>
---	---



EAS20921

### CLEANING THE AIR FILTER ELEMENT

**TIP** \_\_\_\_\_  
 There is a check hose “1” at the bottom of the air filter case. If dust and/or water collects in this hose, clean the air filter element and air filter case.

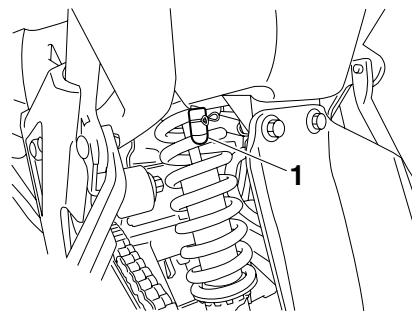

1. Remove:
  - Seat
  - Seat bracket
 Refer to "GENERAL CHASSIS" on page 4-1.
2. Remove:
  - Air filter case cover "1"
  - Air filter element

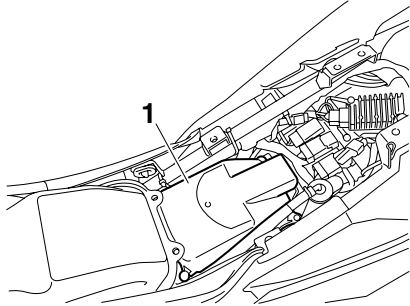

3. Clean:
  - Air filter element "1"
 Apply compressed air to the outer surface of the air filter element.

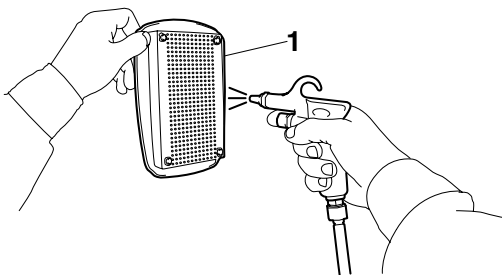

4. Check:
  - Air filter element
 Damage → Replace.
5. Install:
  - Air filter element
  - Air filter case cover
 (along with the gaskets)

ECA22B1003

**NOTICE**

**Never operate the engine without the air filter element installed. Unfiltered air will cause rapid wear of engine parts and may damage the engine. Operating the engine without the air filter element will also affect throttle body tuning, leading to poor engine performance and possible overheating.**

**TIP**

Make sure the air filter element is properly installed in the air filter case.

6. Install:
  - Seat bracket

- Seat
- Refer to "GENERAL CHASSIS" on page 4-1.

EAS22B1003

**CHECKING THE THROTTLE BODY JOINT AND AIR FILTER CASE JOINT**

1. Check:
  - Throttle body joint "1"
  - Air filter case joint "2"
 Cracks/damage → Replace.

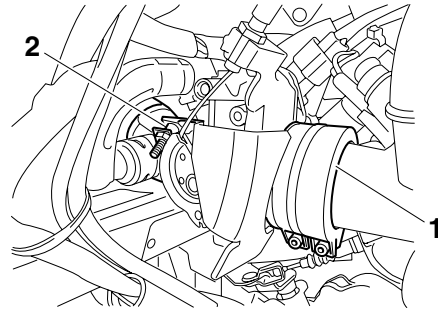

EAS21030

**CHECKING THE FUEL LINE**

1. Check:
  - Fuel hose "1"
 Cracks/damage → Replace.  
 Loose connection → Connect properly.

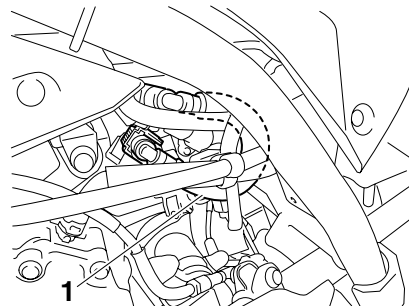

EAS21050

**CHECKING THE CYLINDER HEAD BREATHER HOSE**

1. Check:
  - Cylinder head breather hose "1"
 Cracks/damage → Replace.  
 Loose connection → Connect properly.

ECA14920

**NOTICE**

**Make sure the cylinder head breather hose is routed correctly.**

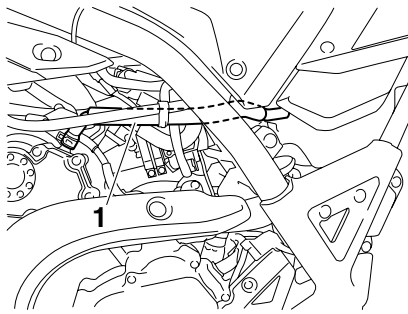

EAS21080

## CHECKING THE EXHAUST SYSTEM

1. Check:
  - Exhaust pipe "1"
  - Muffler "2"
  - Cracks/damage → Replace.
  - Gaskets "3"
  - Exhaust gas leaks → Replace.
2. Check:
  - Tightening torques
  - Exhaust pipe nuts "4"
  - Muffler bolts "5"
  - Muffler clamp bolt "6"

	<b>Exhaust pipe nut</b> 20 Nm (2.0 m-kgf, 14 ft-lbf) <b>Muffler bolt</b> 27 Nm (2.7 m-kgf, 19 ft-lbf) <b>Muffler clamp bolt</b> 18 Nm (1.8 m-kgf, 13 ft-lbf)
---	---

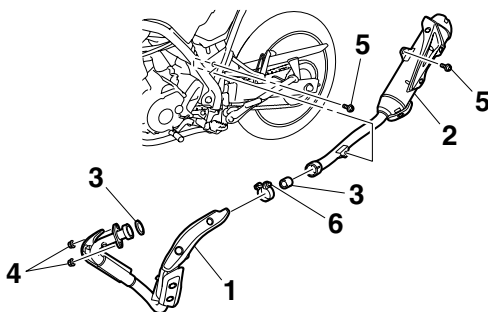

EAS21110

## CHECKING THE COOLANT LEVEL

1. Stand the vehicle on a level surface.

### TIP

- Place the vehicle on a suitable stand.
- Make sure the vehicle is upright.

2. Check:

- Coolant level  
The coolant level should be between the maximum level mark "a" and minimum level mark "b".

Below the minimum level mark → Add the recommended coolant to the proper level.

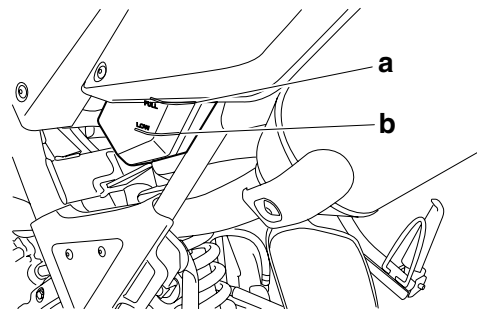

ECA22B1004

### NOTICE

- Adding water instead of coolant lowers the antifreeze content of the coolant. If water is used instead of coolant, check and, if necessary, correct the antifreeze concentration of the coolant.
- Use only distilled water. However, if distilled water is not available, soft water may be used.

3. Start the engine, warm it up for several minutes, and then turn it off.

4. Check:
  - Coolant level

### TIP

Before checking the coolant level, wait a few minutes until it settles.

EAS21120

## CHECKING THE COOLING SYSTEM

1. Remove:
  - Fuel tank cover assembly  
Refer to "GENERAL CHASSIS" on page 4-1.
2. Check:
  - Radiator "1"
  - Radiator inlet hose "2"
  - Radiator outlet hose "3"
  - Coolant reservoir hose "4"
  - Water pump breather hose "5"
  - Cracks/damage → Replace.  
Refer to "RADIATOR" on page 6-1.

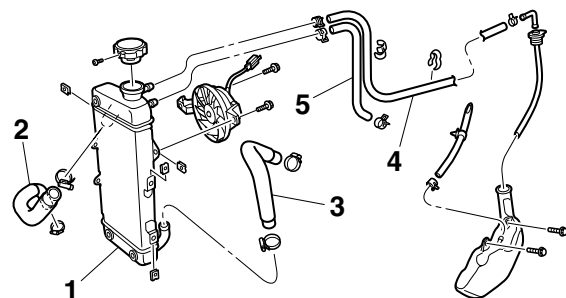

3. Install:
  - Fuel tank cover assembly
 Refer to "GENERAL CHASSIS" on page 4-1.

EAS21130

## CHANGING THE COOLANT

1. Remove:
  - Seat
  - Left rear side cover
 Refer to "GENERAL CHASSIS" on page 4-1.
2. Remove:
  - Radiator cap lock bolt "1"
  - Radiator cap "2"

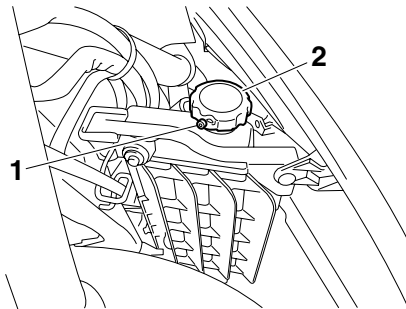

EWA13030

### WARNING

A hot radiator is under pressure. Therefore, do not remove the radiator cap when the engine is hot. Scalding hot fluid and steam may be blown out, which could cause serious injury. When the engine has cooled, open the radiator cap as follows:

Place a thick rag or a towel over the radiator cap and slowly turn the radiator cap counterclockwise toward the detent to allow any residual pressure to escape. When the hissing sound has stopped, press down on the radiator cap and turn it counterclockwise to remove.

3. Remove:
  - Coolant drain bolt "1" (along with the copper washer)

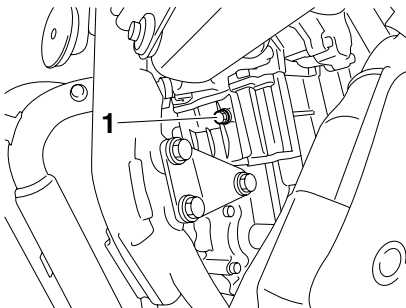

4. Drain:
  - Coolant (from the engine and radiator)
5. Remove:
  - Coolant reservoir cap "1"
  - Coolant reservoir "2"

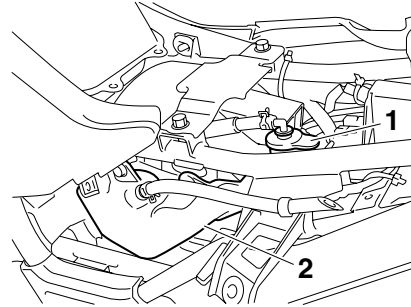

6. Drain:
  - Coolant (from the coolant reservoir)
7. Install:
  - Coolant reservoir



**Coolant reservoir bolt**  
7 Nm (0.7 m·kgf, 5.1 ft·lbf)

8. Install:
  - Coolant drain bolt (along with the copper washer **New**)



**Coolant drain bolt**  
7 Nm (0.7 m·kgf, 5.1 ft·lbf)

9. Fill:
  - Cooling system (with the specified amount of the recommended coolant)



**Recommended antifreeze**  
High-quality ethylene glycol antifreeze containing corrosion inhibitors for aluminum engines  
**Mixing ratio**  
1:1 (antifreeze:water)  
**Radiator capacity (including all routes)**  
1.10 L (1.16 US qt, 0.97 Imp.qt)  
**Coolant reservoir capacity (up to the maximum level mark)**  
0.25 L (0.26 US qt, 0.22 Imp.qt)

### Handling notes for coolant

Coolant is potentially harmful and should be handled with special care.

EWA13040

**WARNING**

- If coolant splashes in your eyes, thoroughly wash them with water and consult a doctor.
- If coolant splashes on your clothes, quickly wash it away with water and then with soap and water.
- If coolant is swallowed, induce vomiting and get immediate medical attention.

ECA22B1005

**NOTICE**

- Adding water instead of coolant lowers the antifreeze content of the coolant. If water is used instead of coolant, check and, if necessary, correct the antifreeze concentration of the coolant.
- Use only distilled water. However, if distilled water is not available, soft water may be used.
- If coolant comes into contact with painted surfaces, immediately wash them with water.
- Do not mix different types of antifreeze.

## 10. Install:

- Radiator cap "1"
- Radiator cap lock bolt "2"



**Radiator cap lock bolt**  
1 Nm (0.1 m·kgf, 0.7 ft·lbf)

**TIP**

Install the radiator cap so that the lock bolt faces forward as shown in the illustration.

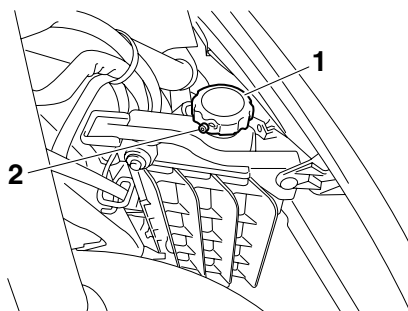

## 11. Fill:

- Coolant reservoir  
(with the recommended coolant to the maximum level mark "a")

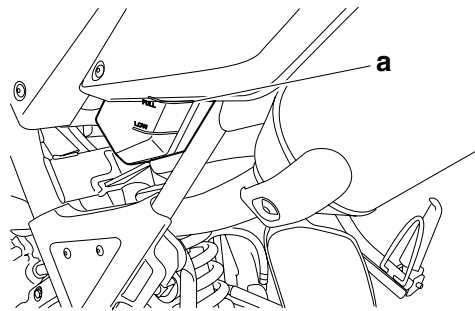

## 12. Install:

- Coolant reservoir cap

## 13. Start the engine, warm it up for several minutes, and then turn it off.

## 14. Check:

- Coolant level  
Refer to "CHECKING THE COOLANT LEVEL" on page 3-14.

**TIP**

Before checking the coolant level, wait a few minutes until the coolant has settled.

## 15. Install:

- Left rear side cover
- Seat

Refer to "GENERAL CHASSIS" on page 4-1.

EAS21140

## CHASSIS

EAS21200

### ADJUSTING THE REAR DISC BRAKE

1. Check:
  - Brake pedal position  
(distance “a” from the top of the rider footrest to the top of the brake pedal)  
Out of specification → Adjust.

	<b>Brake pedal position</b> <b>12.0 mm (0.47 in)</b>
--	---

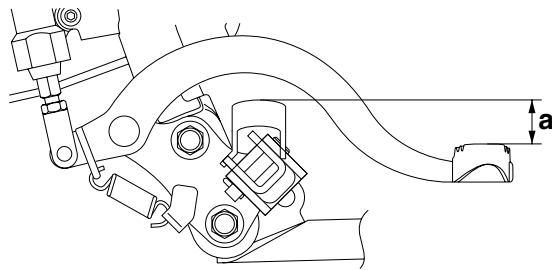

2. Adjust:
  - Brake pedal position

- a. Loosen the locknut “1”.
- b. Turn the adjusting bolt “2” in direction “a” or “b” until the specified brake pedal position is obtained.

<b>Direction “a”</b> <b>Brake pedal is raised.</b>
<b>Direction “b”</b> <b>Brake pedal is lowered.</b>

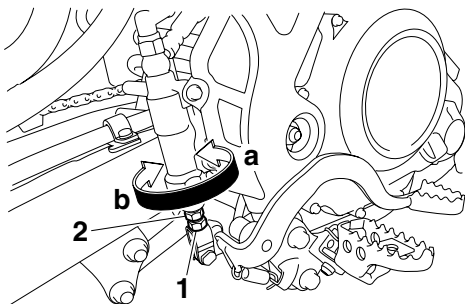

- c. Tighten the locknut “1” to specification.

	<b>Locknut</b> <b>17 Nm (1.7 m·kgf, 12 ft·lbf)</b>
--	---

EWA22B1013

## ⚠ WARNING

A soft or spongy feeling in the brake pedal can indicate the presence of air in the brake system. Before the vehicle is operated, the air must be removed by bleeding the brake system. Air in the brake system will considerably reduce braking performance.

ECA13510

## NOTICE

After adjusting the brake pedal position, make sure there is no brake drag.

EAS21240

### CHECKING THE BRAKE FLUID LEVEL

1. Stand the vehicle on a level surface.

#### TIP

- Place the vehicle on a suitable stand.
- Make sure the vehicle is upright.

2. Check:

- Brake fluid level  
Below the minimum level mark “a” → Add the recommended brake fluid to the proper level.

	<b>Recommended fluid</b> <b>DOT 4</b>
--	--

A

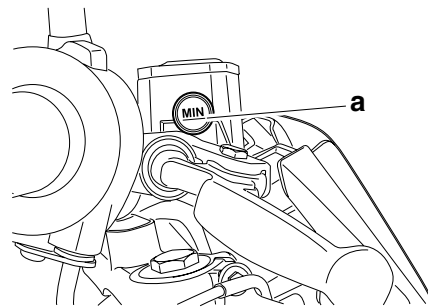

B

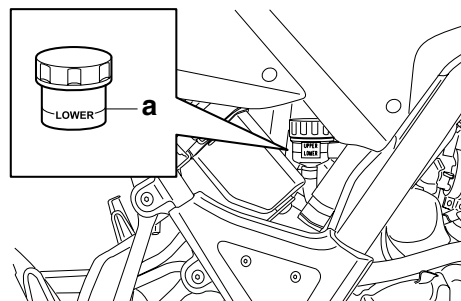

- A. Front brake
- B. Rear brake



EWA22B1014

## WARNING

- Use only the designated brake fluid. Other brake fluids may cause the rubber seals to deteriorate, causing leakage and poor brake performance.
- Refill with the same type of brake fluid that is already in the system. Mixing brake fluids may result in a harmful chemical reaction, leading to poor brake performance.
- When refilling, be careful that water does not enter the brake master cylinder reservoir or brake fluid reservoir. Water will significantly lower the boiling point of the brake fluid and could cause vapor lock.

ECA13540

## NOTICE

Brake fluid may damage painted surfaces and plastic parts. Therefore, always clean up any spilt brake fluid immediately.

## TIP

In order to ensure a correct reading of the brake fluid level, make sure the tops of the brake master cylinder reservoir and brake fluid reservoir are horizontal.

EAS21250

## CHECKING THE FRONT BRAKE PADS

The following procedure applies to all of the brake pads.

1. Operate the brake.
2. Check:
  - Front brake pad  
Brake pad wear limit "a"  
Out of specification → Replace the brake pads as a set.  
Refer to "FRONT BRAKE" on page 4-19.



**Brake pad lining thickness (inner)**  
 5.0 mm (0.20 in)  
**Limit**  
 1.0 mm (0.04 in)  
**Brake pad lining thickness (outer)**  
 5.0 mm (0.20 in)  
**Limit**  
 1.0 mm (0.04 in)

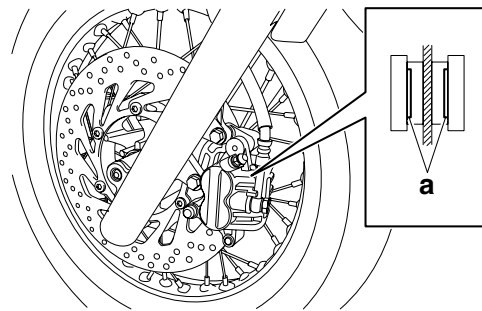

EAS21260

## CHECKING THE REAR BRAKE PADS

The following procedure applies to all of the brake pads.

1. Operate the brake.
2. Check:
  - Rear brake pad  
Brake pad wear limit "a"  
Out of specification → Replace the brake pads as a set.  
Refer to "REAR BRAKE" on page 4-30.



**Brake pad lining thickness (inner)**  
 6.0 mm (0.24 in)  
**Limit**  
 1.0 mm (0.04 in)  
**Brake pad lining thickness (outer)**  
 6.0 mm (0.24 in)  
**Limit**  
 1.0 mm (0.04 in)

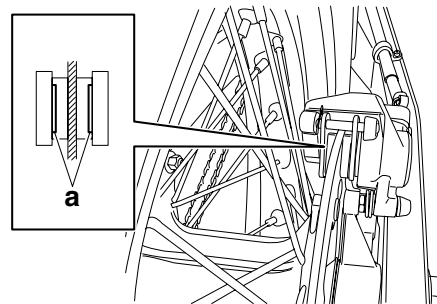

EAS21270

## CHECKING THE FRONT BRAKE HOSE

1. Check:
  - Brake hose  
Cracks/damage/wear → Replace.
2. Check:
  - Brake hose holders  
Loose connection → Tighten the holder bolts.



**TIP**

Loosening the bleed screw will release the pressure and cause the brake lever to contact the throttle grip or the brake pedal to fully extend.

- h. Tighten the bleed screw, and then release the brake lever or brake pedal.
- i. Repeat steps (e) to (h) until all of the air bubbles have disappeared from the brake fluid in the plastic hose.
- j. Tighten the bleed screw to specification.

	<p><b>Front brake caliper bleed screw</b> 6 Nm (0.6 m-kgf, 4.3 ft-lbf)</p> <p><b>Rear brake caliper bleed screw</b> 6 Nm (0.6 m-kgf, 4.3 ft-lbf)</p>
---	--

- k. Fill the brake master cylinder reservoir or brake fluid reservoir to the proper level with the recommended brake fluid. Refer to "CHECKING THE BRAKE FLUID LEVEL" on page 3-17.

EWA13110

**⚠ WARNING**

**After bleeding the hydraulic brake system, check the brake operation.**



- 4. Install:
  - Brake fluid reservoir bolt
  - Owner's tool kit
- 5. Install:
  - Right rear side cover

Refer to "GENERAL CHASSIS" on page 4-1.

EAS21390

**ADJUSTING THE DRIVE CHAIN SLACK**

**TIP**

The drive chain slack must be checked at the tightest point on the chain.

ECA13550

**NOTICE**

**A drive chain that is too tight will overload the engine and other vital parts, and one that is too loose can skip and damage the swingarm or cause an accident. Therefore, keep the drive chain slack within the specified limits.**

- 1. Stand the vehicle on a level surface.

EWA13120

**⚠ WARNING**

**Securely support the vehicle so that there is no danger of it falling over.**

**TIP**

Place the vehicle on a suitable stand so that the rear wheel is elevated.

- 2. Move the rear wheel several times and find the tightest position of the drive chain.
- 3. Check:
  - Drive chain slack "a"

Out of specification → Adjust.

	<p><b>Drive chain slack</b> 40.0–50.0 mm (1.57–1.97 in)</p>
---	---

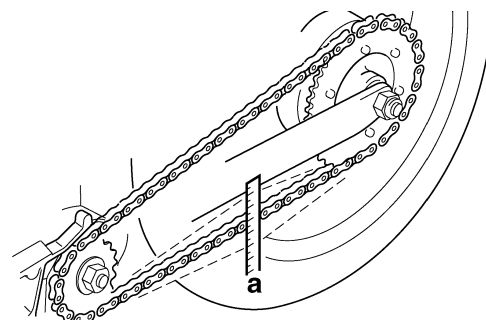

- 4. Adjust:
  - Drive chain slack



- a. Loosen the rear wheel axle nut "1".
- b. Loosen both locknuts "2".
- c. Turn both adjusting nuts "3" in direction "a" or "b" until the specified drive chain slack is obtained.

<p><b>Direction "a"</b> Drive chain is tightened.</p> <p><b>Direction "b"</b> Drive chain is loosened.</p>
--

**TIP**

- To maintain the proper wheel alignment, adjust both sides evenly.
- Push the rear wheel forward to make sure there is no clearance between the swingarm end plates and the ends of the swingarm.

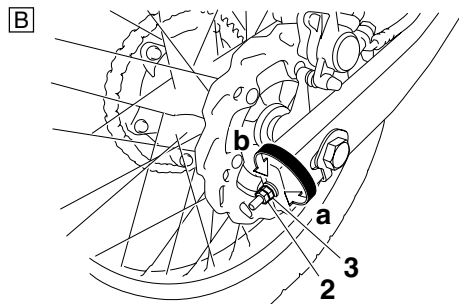
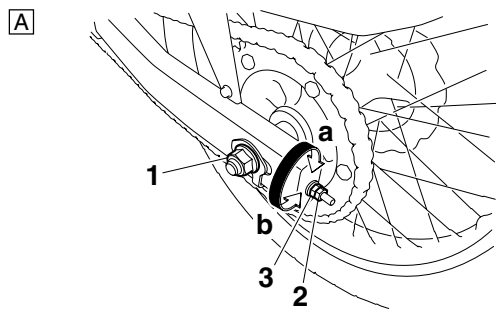

A. Left side  
B. Right side

d. Tighten the rear wheel axle nut to specification.

	<b>Rear wheel axle nut</b> <b>90 Nm (9.0 m·kgf, 65 ft·lbf)</b>
---	---

e. Tighten the locknuts to specification.

	<b>Drive chain adjusting locknut</b> <b>16 Nm (1.6 m·kgf, 11 ft·lbf)</b>
---	---

EAS21440

### LUBRICATING THE DRIVE CHAIN

The drive chain consists of many interacting parts. If the drive chain is not maintained properly, it will wear out quickly. Therefore, the drive chain should be serviced, especially when the vehicle is used in dusty areas.

This vehicle has a drive chain with small rubber O-rings between each side plate. Steam cleaning, high-pressure washing, certain solvents, and the use of a coarse brush can damage these O-rings. Therefore, use only kerosene to clean the drive chain. Wipe the drive chain dry and thoroughly lubricate it with engine oil or chain lubricant that is suitable for O-ring chains. Do not use any other lubricants on the drive chain since they may contain solvents that could damage the O-rings.

	<b>Recommended lubricant</b> <b>Engine oil or chain lubricant</b> <b>suitable for O-ring chains</b>
---	---

EAS21510

### CHECKING AND ADJUSTING THE STEERING HEAD

1. Stand the vehicle on a level surface.

EWA13120

#### **WARNING**

**Securely support the vehicle so that there is no danger of it falling over.**

#### **TIP**

Place the vehicle on a suitable stand so that the front wheel is elevated.

2. Check:

- **Steering head**  
Grasp the bottom of the front fork legs and gently rock the front fork.  
Binding/looseness → Adjust the steering head.

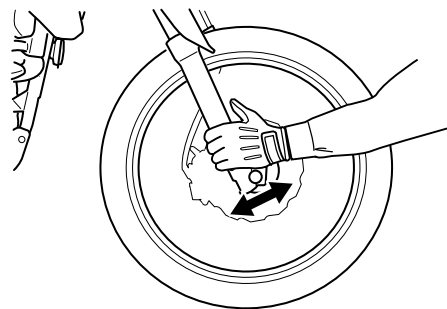

3. Remove:

- Upper bracket  
Refer to "STEERING HEAD" on page 4-55.

4. Adjust:

- Steering head

a. Remove the lock washer "1", the upper ring nut "2", and the rubber washer "3".

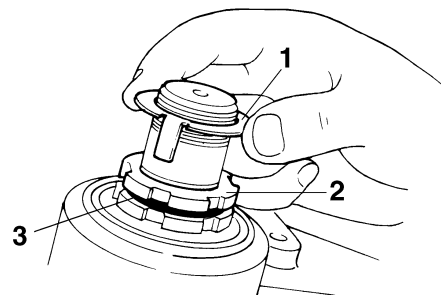

b. Loosen the lower ring nut "4", and then tighten it to specification with a steering nut wrench "5".

	<b>Steering nut wrench</b> 90890-01403 <b>Exhaust flange nut wrench</b> YU-A9472
---	---

	<b>Lower ring nut (initial tightening torque)</b> 38 Nm (3.8 m-kgf, 27 ft-lbf)
---	---

**TIP**  
Set the torque wrench at a right angle to the steering nut wrench.

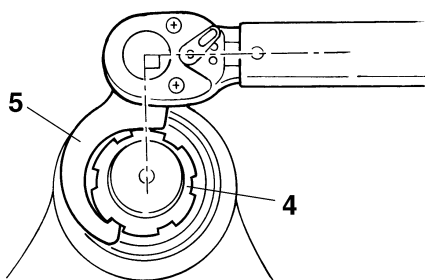

c. Loosen the lower ring nut completely, and then tighten it to specification with a steering nut wrench.

EWA13140  
**WARNING**  
**Do not overtighten the lower ring nut.**

	<b>Lower ring nut (final tightening torque)</b> 4 Nm (0.4 m-kgf, 2.9 ft-lbf)
---	---

- d. Check the steering head for looseness or binding by turning the front fork all the way in both directions. If any binding is felt, remove the lower bracket and check the upper and lower bearings. Refer to "STEERING HEAD" on page 4-55.
- e. Install the rubber washer "3".
- f. Install the upper ring nut "2".
- g. Finger tighten the upper ring nut, and then align the slots of both ring nuts. If necessary, hold the lower ring nut and tighten the upper ring nut until their slots are aligned.
- h. Install the lock washer "1".

**TIP**  
Make sure the lock washer tabs "a" sit correctly in the ring nut slots "b".

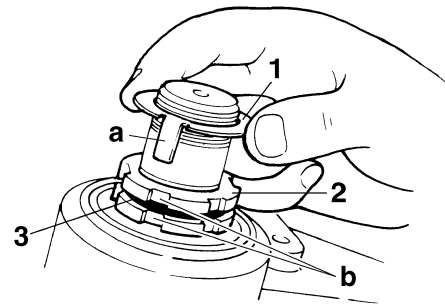

5. Install:
- Upper bracket
- Refer to "STEERING HEAD" on page 4-55.

EAS21530  
**CHECKING THE FRONT FORK**  
 1. Stand the vehicle on a level surface.

EWA13120  
**WARNING**  
**Securely support the vehicle so that there is no danger of it falling over.**

- 2. Check:
  - Inner tube  
Damage/scratches → Replace.
  - Oil seal  
Oil leakage → Replace.
- 3. Hold the vehicle upright and apply the front brake.
- 4. Check:
  - Front fork operation  
Push down hard on the handlebar several times and check if the front fork rebounds smoothly.  
Rough movement → Repair.  
Refer to "FRONT FORK" on page 4-46.

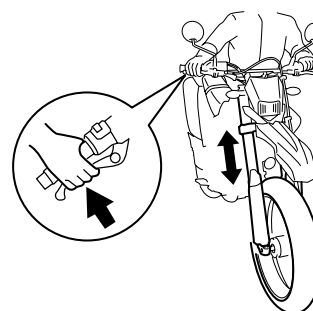

EAS21590  
**ADJUSTING THE REAR SHOCK ABSORBER ASSEMBLY**

EWA13120  
**WARNING**  
**Securely support the vehicle so that there is no danger of it falling over.**

## Spring preload

ECA13590

### NOTICE

Never go beyond the maximum or minimum adjustment positions.

1. Remove:
  - Rear mudguard "1"

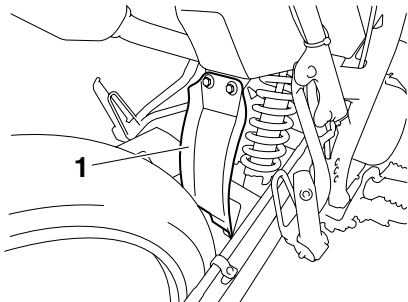

2. Adjust:
  - Spring preload

- a. Adjust the spring preload with the special wrench "1" that is provided in the owner's tool kit.
- b. Turn the adjusting ring "2" in direction "a" or "b".
- c. Align the desired position on the adjusting ring with the stopper "3".

**Direction "a"**  
Spring preload is increased (suspension is harder).

**Direction "b"**  
Spring preload is decreased (suspension is softer).

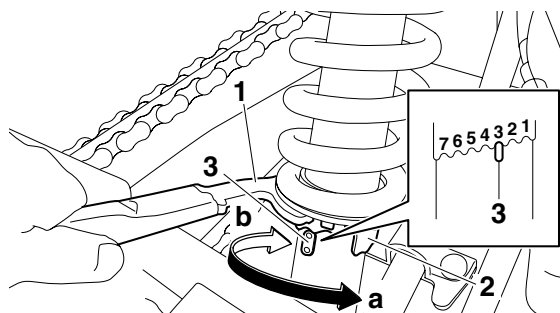

### Spring preload adjusting positions

Minimum

1

Standard

3

Maximum

7

EAS21660

### CHECKING THE TIRES

The following procedure applies to both of the tires.

1. Check:
  - Tire pressure
  - Out of specification → Regulate.

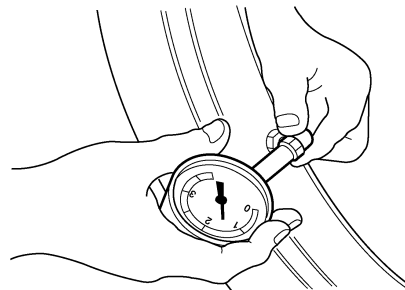

EWA13180

### WARNING

- The tire pressure should only be checked and regulated when the tire temperature equals the ambient air temperature.
- The tire pressure and the suspension must be adjusted according to the total weight (including cargo, rider, passenger and accessories) and the anticipated riding speed.
- Operation of an overloaded vehicle could cause tire damage, an accident or an injury. **NEVER OVERLOAD THE VEHICLE.**



**Tire air pressure (measured on cold tires)**

**Loading condition**  
 0–90 kg (0–198 lb)

**Front**  
 200 kPa (2.00 kgf/cm<sup>2</sup>, 29 psi)

**Rear**  
 200 kPa (2.00 kgf/cm<sup>2</sup>, 29 psi)

**Loading condition**  
 90–185 kg (198–408 lb)

**Front**  
 200 kPa (2.00 kgf/cm<sup>2</sup>, 29 psi)

**Rear**  
 225 kPa (2.25 kgf/cm<sup>2</sup>, 33 psi)

**Maximum load**  
 185 kg (408 lb)

**\* Total weight of rider, passenger, cargo and accessories**

EWA13190

**WARNING**

It is dangerous to ride with a worn-out tire. When the tire tread reaches the wear limit, replace the tire immediately.

2. Check:

- Tire surfaces  
 Damage/wear → Replace the tire.

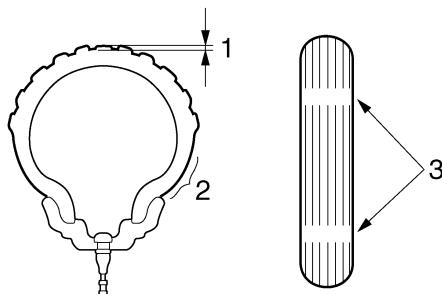

1. Tire tread depth
2. Side wall
3. Wear indicator



**Wear limit (front)**  
 1.6 mm (0.06 in)

**Wear limit (rear)**  
 1.6 mm (0.06 in)

EWA14080

**WARNING**

- Do not use a tubeless tire on a wheel designed only for tube tires to avoid tire failure and personal injury from sudden deflation.

- When using a tube tire, be sure to install the correct tube.
- Always replace a new tube tire and a new tube as a set.
- To avoid pinching the tube, make sure the wheel rim band and tube are centered in the wheel groove.
- Patching a punctured tube is not recommended. If it is absolutely necessary to do so, use great care and replace the tube as soon as possible with a good quality replacement.

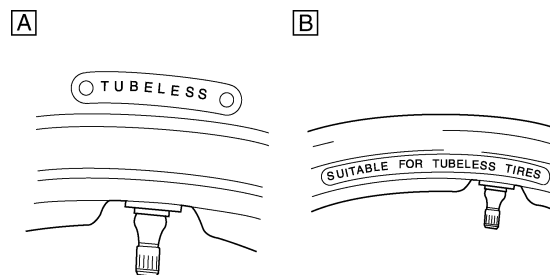

- A. Tire  
 B. Wheel

Tube wheel	Tube tire only
Tubeless wheel	Tube or tubeless tire

EWA14090

**WARNING**

After extensive tests, the tires listed below have been approved by Yamaha Motor Co., Ltd. for this model. The front and rear tires should always be by the same manufacturer and of the same design. No guarantee concerning handling characteristics can be given if a tire combination other than one approved by Yamaha is used on this vehicle.



**Front tire**

**Size**  
 WR125R 80/90–21 M/C 48P  
 WR125R 80/90–21 M/C 48S  
 WR125R 80/90–21 M/C 48R  
 WR125X 110/70–17 M/C 54H

**Manufacturer/model**  
 WR125R MICHELIN/T63  
 WR125R PIRELLI/MT21  
 WR125R PIRELLI/SCORPION A/T  
 WR125R MICHELIN/SIRAC  
 WR125X PIRELLI/SPORT DEMON



**Rear tire**  
**Size**  
 WR125R 110/80-18 M/C 58P  
 WR125R 110/80-18 M/C 58S  
 WR125R 110/80-18 M/C 58R  
 WR125X 140/70-17 M/C 66H  
**Manufacturer/model**  
 WR125R MICHELIN/T63  
 WR125R PIRELLI/MT21  
 WR125R PIRELLI/SCORPION  
 A/T  
 WR125R MICHELIN/SIRAC  
 WR125X PIRELLI/SPORT DE-  
 MON

EWA22B1015

**WARNING**

New tires have a relatively low grip on the road surface until they have been slightly worn. Therefore, approximately 100 km should be traveled at normal speed before any high-speed riding is done.

**TIP**

- For tires with a direction of rotation mark "1":
- Install the tire with the mark pointing in the direction of wheel rotation.
  - Align the mark "2" with the valve installation point.

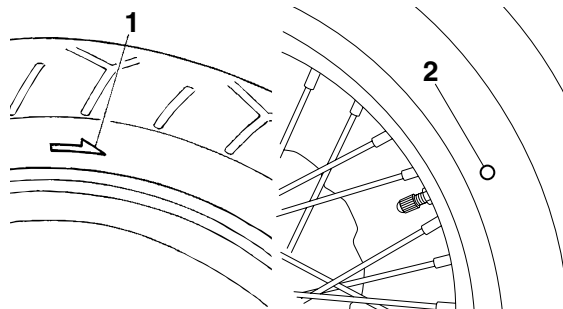

EAS21670

**CHECKING THE WHEELS**

The following procedure applies to both of the wheels.

1. Check:
  - Wheel  
 Damage/out-of-round → Replace.

EWA13260

**WARNING**

Never attempt to make any repairs to the wheel.

**TIP**

After a tire or wheel has been changed or replaced, always balance the wheel.

EAS21680

**CHECKING AND TIGHTENING THE SPOKES**

The following procedure applies to all of the spokes.

1. Check:
  - Spoke  
 Bends/damage → Replace.  
 Loose → Tighten.  
 Tap the spokes with a screwdriver.

**TIP**

A tight spoke will emit a clear, ringing tone, a loose spoke will sound flat.

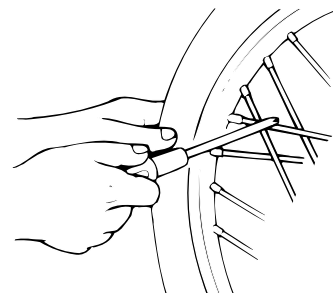

2. Tighten:
  - Spoke  
 (with a spoke nipple wrench "1")



**Spoke**  
**3 Nm (0.3 m·kgf, 2.2 ft·lbf)**

**WR125X:**



**Spoke nipple wrench (8-9)**  
**90890-01522**  
**YM-01522**

**WR125R:**



**Spoke nipple wrench (10-11)**  
**90890-01523**  
**YM-01523**

**TIP**

Be sure to tighten the spokes before and after break-in.



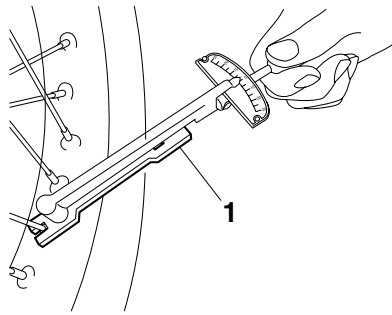

EAS21690

**CHECKING AND LUBRICATING THE CABLES**

The following procedure applies to all of the inner and outer cables.

EWA22B1017



**A damaged outer cable may cause the cable to corrode and interfere with its movement. Replace damaged outer cables and inner cables as soon as possible.**

1. Check:
  - Outer cable  
Damage → Replace.
2. Check:
  - Cable operation  
Rough movement → Lubricate.

	<b>Recommended lubricant Engine oil or a suitable cable lubricant</b>
---	---

**TIP**

Hold the cable end upright and pour a few drops of lubricant into the cable sheath or use a suitable lubricating device.

EAS22B1035

**LUBRICATING THE CLUTCH LEVER**

Lubricate the pivoting point and metal-to-metal moving parts of the lever.

	<b>Recommended lubricant Lithium-soap-based grease</b>
---	--

EAS22B1036

**LUBRICATING THE BRAKE LEVER**

Lubricate the pivoting point and metal-to-metal moving parts of the lever.

	<b>Recommended lubricant Silicone grease</b>
---	--

EAS21710

**LUBRICATING THE BRAKE PEDAL**

Lubricate the pivoting point and metal-to-metal moving parts of the pedal.

	<b>Recommended lubricant Lithium-soap-based grease</b>
---	--

EAS21720

**LUBRICATING THE SIDESTAND**

Lubricate the pivoting point and metal-to-metal moving parts of the sidestand.

	<b>Recommended lubricant Lithium-soap-based grease</b>
---	--

EAS21740

**LUBRICATING THE REAR SUSPENSION**

Lubricate the pivoting point and metal-to-metal moving parts of the rear suspension.

	<b>Recommended lubricant Lithium-soap-based grease</b>
---	--

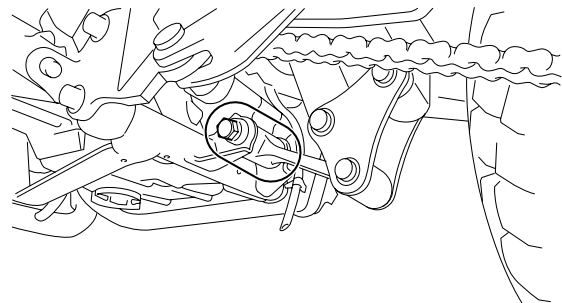



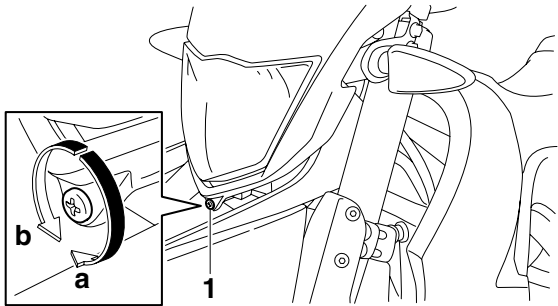



---

## CHASSIS

<b>GENERAL CHASSIS</b> .....	4-1
REMOVING THE REAR SIDE COVERS .....	4-5
INSTALLING THE AIR FILTER CASE .....	4-5
<b>FRONT WHEEL</b> .....	4-6
REMOVING THE FRONT WHEEL (DISC).....	4-10
DISASSEMBLING THE FRONT WHEEL.....	4-10
CHECKING THE FRONT WHEEL .....	4-10
ASSEMBLING THE FRONT WHEEL.....	4-11
INSTALLING THE FRONT WHEEL (DISC) .....	4-11
<b>REAR WHEEL</b> .....	4-13
REMOVING THE REAR WHEEL (DISC) .....	4-17
DISASSEMBLING THE REAR WHEEL .....	4-17
CHECKING THE REAR WHEEL.....	4-17
CHECKING AND REPLACING THE REAR WHEEL SPROCKET .....	4-17
ASSEMBLING THE REAR WHEEL .....	4-18
INSTALLING THE REAR WHEEL (DISC).....	4-18
<b>FRONT BRAKE</b> .....	4-19
INTRODUCTION.....	4-23
CHECKING THE FRONT BRAKE DISC .....	4-23
REPLACING THE FRONT BRAKE PADS .....	4-24
REMOVING THE FRONT BRAKE CALIPER.....	4-25
DISASSEMBLING THE FRONT BRAKE CALIPER .....	4-25
CHECKING THE FRONT BRAKE CALIPER .....	4-25
ASSEMBLING THE FRONT BRAKE CALIPER .....	4-26
INSTALLING THE FRONT BRAKE CALIPER .....	4-26
REMOVING THE FRONT BRAKE MASTER CYLINDER.....	4-27
CHECKING THE FRONT BRAKE MASTER CYLINDER.....	4-27
INSTALLING THE FRONT BRAKE MASTER CYLINDER.....	4-27
<b>REAR BRAKE</b> .....	4-30
INTRODUCTION .....	4-36
CHECKING THE REAR BRAKE DISC.....	4-36
REPLACING THE REAR BRAKE PADS.....	4-36
REMOVING THE REAR BRAKE CALIPER .....	4-37
DISASSEMBLING THE REAR BRAKE CALIPER .....	4-37
CHECKING THE REAR BRAKE CALIPER.....	4-38
ASSEMBLING THE REAR BRAKE CALIPER .....	4-38
INSTALLING THE REAR BRAKE CALIPER.....	4-38
REMOVING THE REAR BRAKE MASTER CYLINDER .....	4-39
CHECKING THE REAR BRAKE MASTER CYLINDER .....	4-39
ASSEMBLING THE REAR BRAKE MASTER CYLINDER.....	4-40
INSTALLING THE REAR BRAKE MASTER CYLINDER .....	4-40

# YamahaR125.COM

---

<b>HANDLEBAR</b> .....	4-41
REMOVING THE HANDLEBAR .....	4-43
CHECKING THE HANDLEBAR .....	4-43
INSTALLING THE HANDLEBAR .....	4-43
<b>FRONT FORK</b> .....	4-46
REMOVING THE FRONT FORK LEGS .....	4-50
DISASSEMBLING THE FRONT FORK LEGS .....	4-50
CHECKING THE FRONT FORK LEGS .....	4-51
ASSEMBLING THE FRONT FORK LEGS .....	4-51
INSTALLING THE FRONT FORK LEGS .....	4-54
<b>STEERING HEAD</b> .....	4-55
REMOVING THE LOWER BRACKET .....	4-58
CHECKING THE STEERING HEAD .....	4-58
INSTALLING THE STEERING HEAD .....	4-58
<b>REAR SHOCK ABSORBER ASSEMBLY</b> .....	4-60
HANDLING THE REAR SHOCK ABSORBER ASSEMBLY (WR125R).....	4-61
DISPOSING OF A REAR SHOCK ABSORBER ASSEMBLY (WR125R).....	4-61
REMOVING THE REAR SHOCK ABSORBER ASSEMBLY .....	4-61
CHECKING THE REAR SHOCK ABSORBER ASSEMBLY .....	4-61
CHECKING THE CONNECTING ROD AND RELAY ARMS .....	4-61
INSTALLING THE RELAY ARMS AND CONNECTING ROD .....	4-61
<b>SWINGARM</b> .....	4-63
REMOVING THE SWINGARM.....	4-65
CHECKING THE SWINGARM .....	4-65
INSTALLING THE SWINGARM .....	4-65
<b>CHAIN DRIVE</b> .....	4-67
REMOVING THE DRIVE CHAIN.....	4-68
CHECKING THE DRIVE CHAIN .....	4-68
CHECKING THE DRIVE SPROCKET.....	4-69
CHECKING THE REAR WHEEL SPROCKET .....	4-69
INSTALLING THE DRIVE CHAIN .....	4-69

YamahaR125.COM

---

EAS21830

**GENERAL CHASSIS**

**Removing the seat and covers**

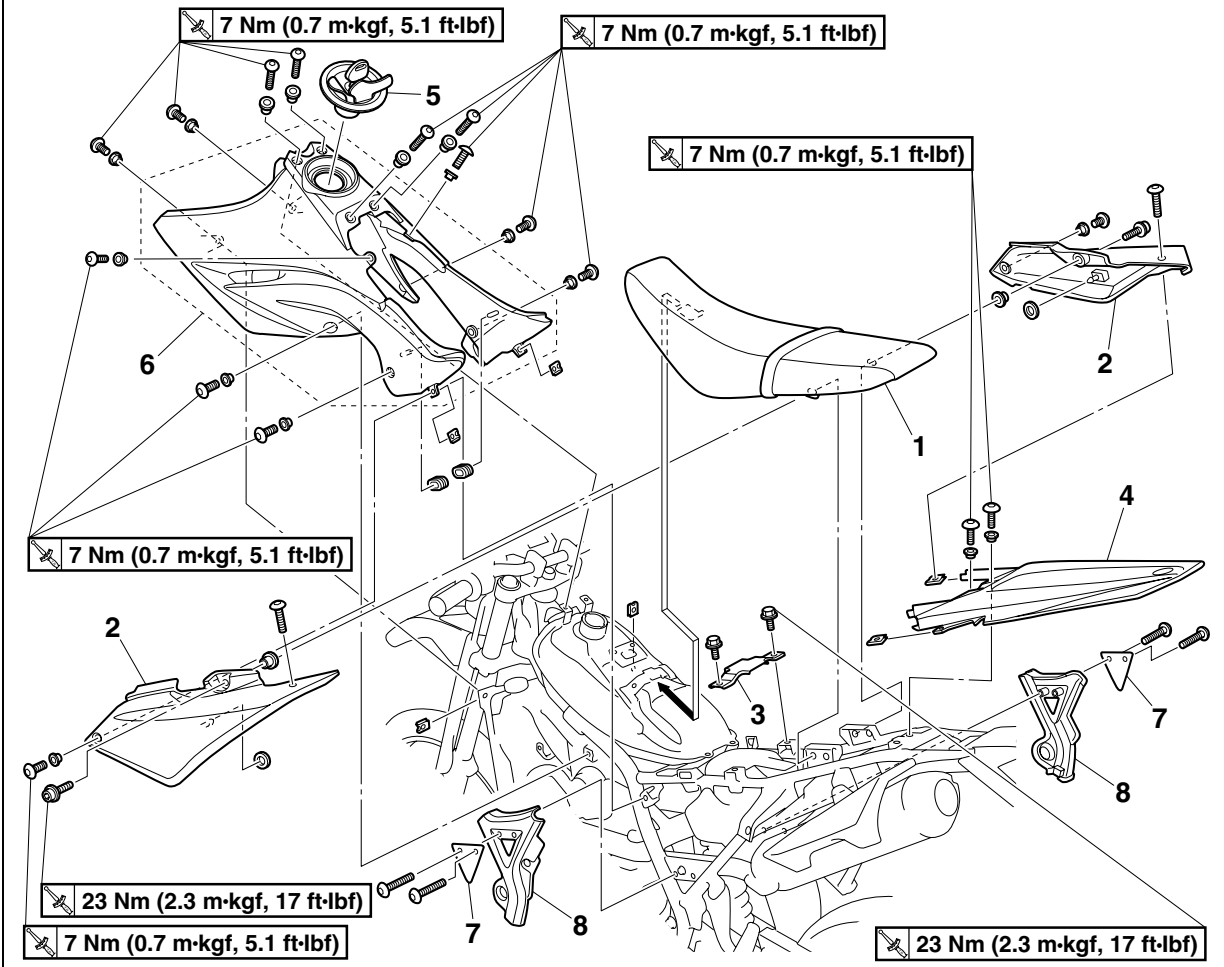

Order	Job/Parts to remove	Q'ty	Remarks
1	Seat	1	
2	Rear side cover	2	
3	Seat bracket	1	
4	Rear fender	1	
5	Fuel tank cap	1	
6	Fuel tank cover assembly	1	
7	Side panel plate	2	WR125X
8	Side panel	2	
			For installation, reverse the removal procedure.



Disassembling the fuel tank cover

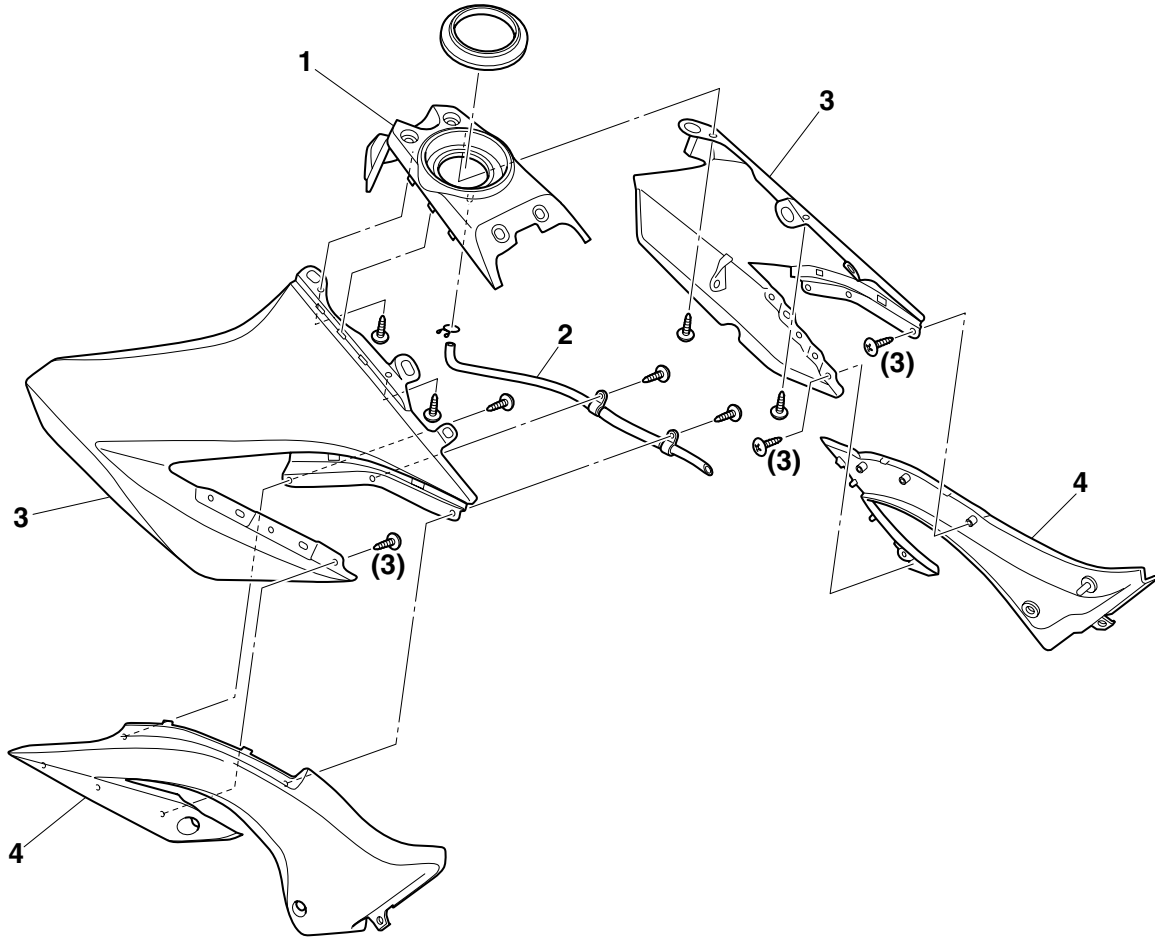

Order	Job/Parts to remove	Q'ty	Remarks
1	Fuel tank top cover	1	
2	Fuel overflow hose	1	
3	Fuel tank front side cover	2	
4	Fuel tank rear side cover	2	
			For assembly, reverse the disassembly procedure.

Removing the battery and battery box

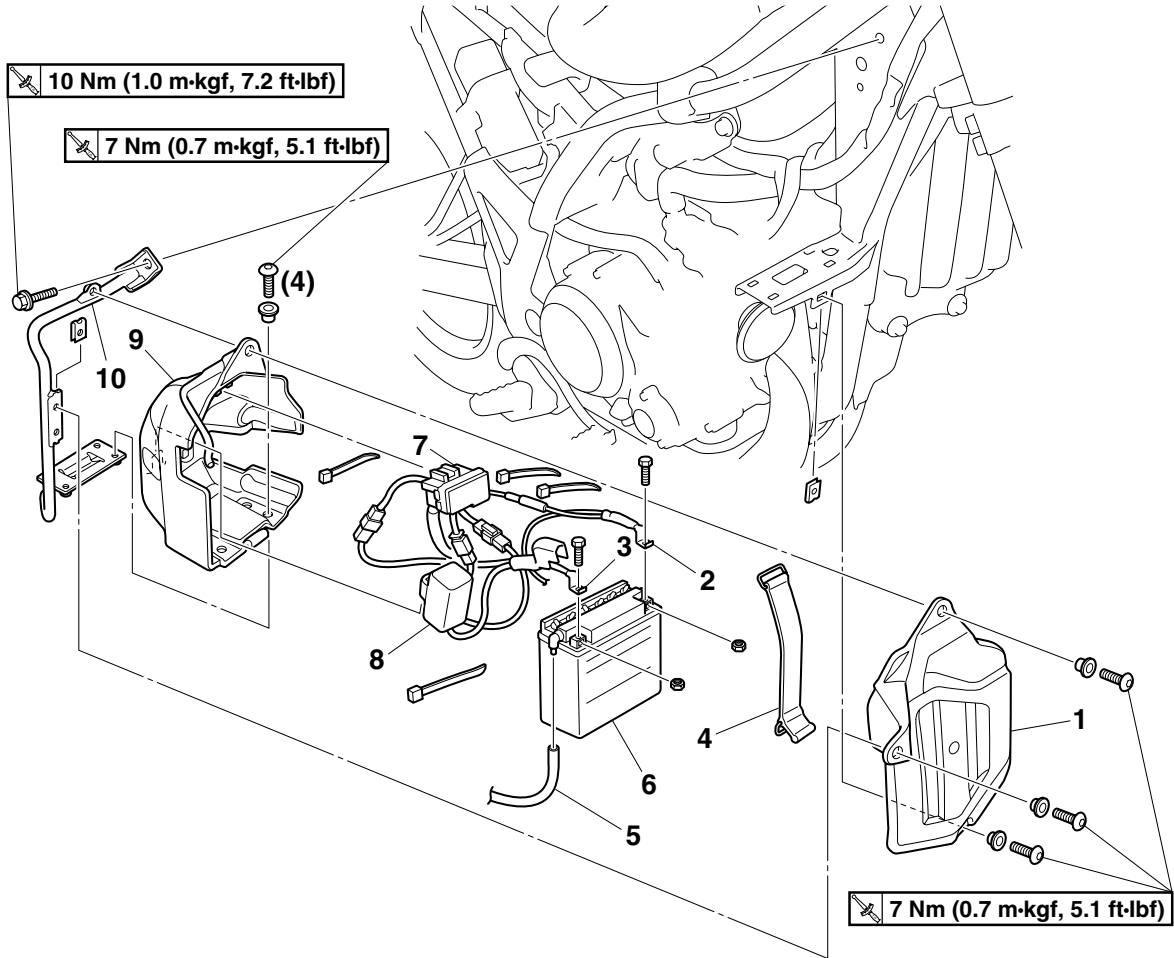

Order	Job/Parts to remove	Q'ty	Remarks
	Fuel tank cover assembly		Refer to "Removing the seat and covers".
1	Battery cover	1	
2	Negative battery lead	1	Disconnect.
3	Positive battery lead	1	Disconnect.
4	Battery band	1	
5	Battery breather hose	1	Disconnect.
6	Battery	1	
7	Fuse box	1	
8	Starter relay	1	
9	Battery box	1	
10	Battery bracket	1	
			For installation, reverse the removal procedure.

Removing the air filter case

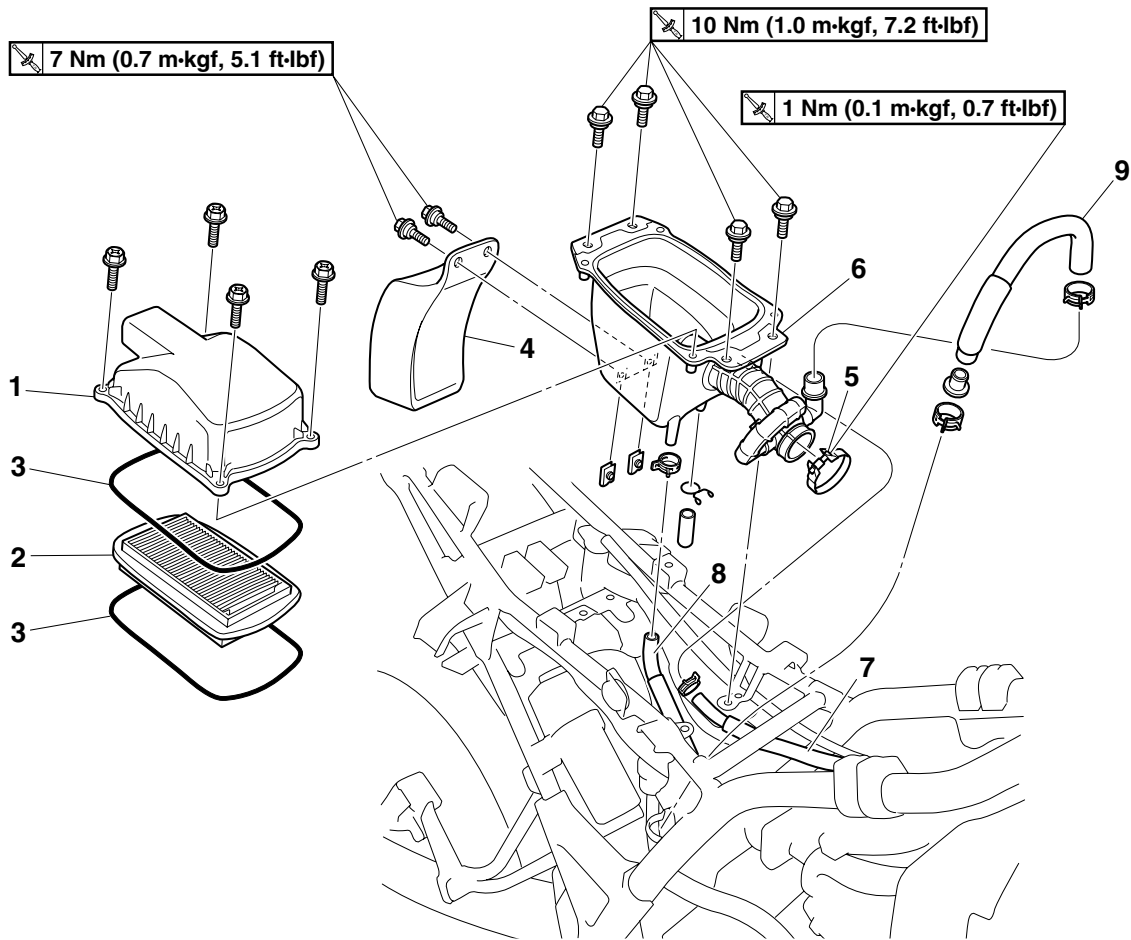

Order	Job/Parts to remove	Q'ty	Remarks
	Seat bracket/Fuel tank cover assembly		Refer to "Removing the seat and covers".
	Fuel tank		Refer to "FUEL TANK" on page 7-1.
1	Air filter case cover	1	
2	Air filter element	1	
3	Air filter case seal	2	
4	Rear mudguard	1	
5	Air filter case joint clamp screw	1	Loosen.
6	Air filter case	1	
7	Cylinder head breather hose	1	Disconnect.
8	Air induction system hose (air filter case to reed valve assembly)	1	Disconnect.
9	Air filter case silencer hose	1	
			For installation, reverse the removal procedure.

EAS22B1037

## REMOVING THE REAR SIDE COVERS

1. Remove:
  - Rear side covers

### TIP

To remove a rear side cover "1", remove the projection "a" on the side cover from the grommet in the frame, and then remove the side cover from the rear fender by sliding it toward the rear of the vehicle.

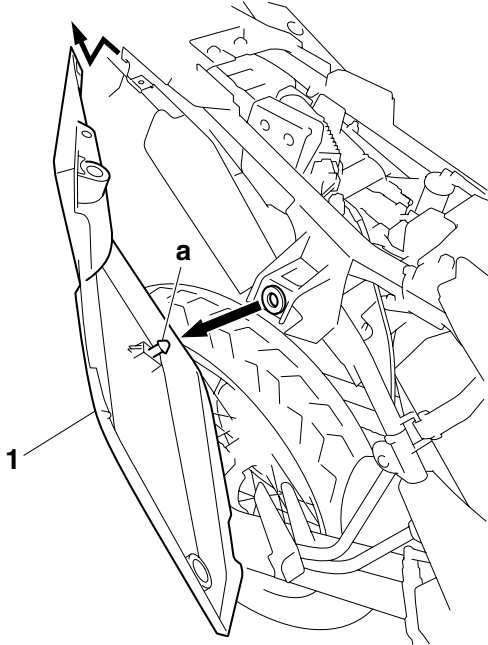

EAS22B1033

## INSTALLING THE AIR FILTER CASE

1. Install:
  - Air filter case joint clamp

### TIP

Align the projection "a" on the air filter case with the slot "b" in the air filter case joint clamp.

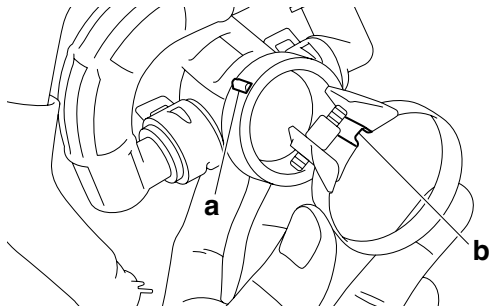

2. Install:
  - Air filter case

### TIP

Temporarily tighten the air filter case bolts.

3. Tighten:
  - Air filter case joint clamp screw



**Air filter case joint clamp screw**  
1 Nm (0.1 m·kgf, 0.7 ft·lbf)

4. Tighten:
  - Air filter case bolts



**Air filter case bolt**  
10 Nm (1.0 m·kgf, 7.2 ft·lbf)

### TIP

Tighten the air filter case bolts in the proper tightening sequence as shown.

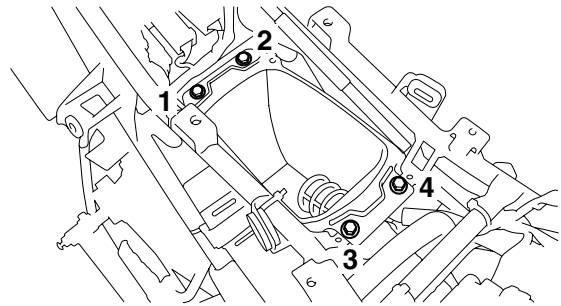

EAS21870

## FRONT WHEEL

### Removing the front wheel and brake disc (WR125R)

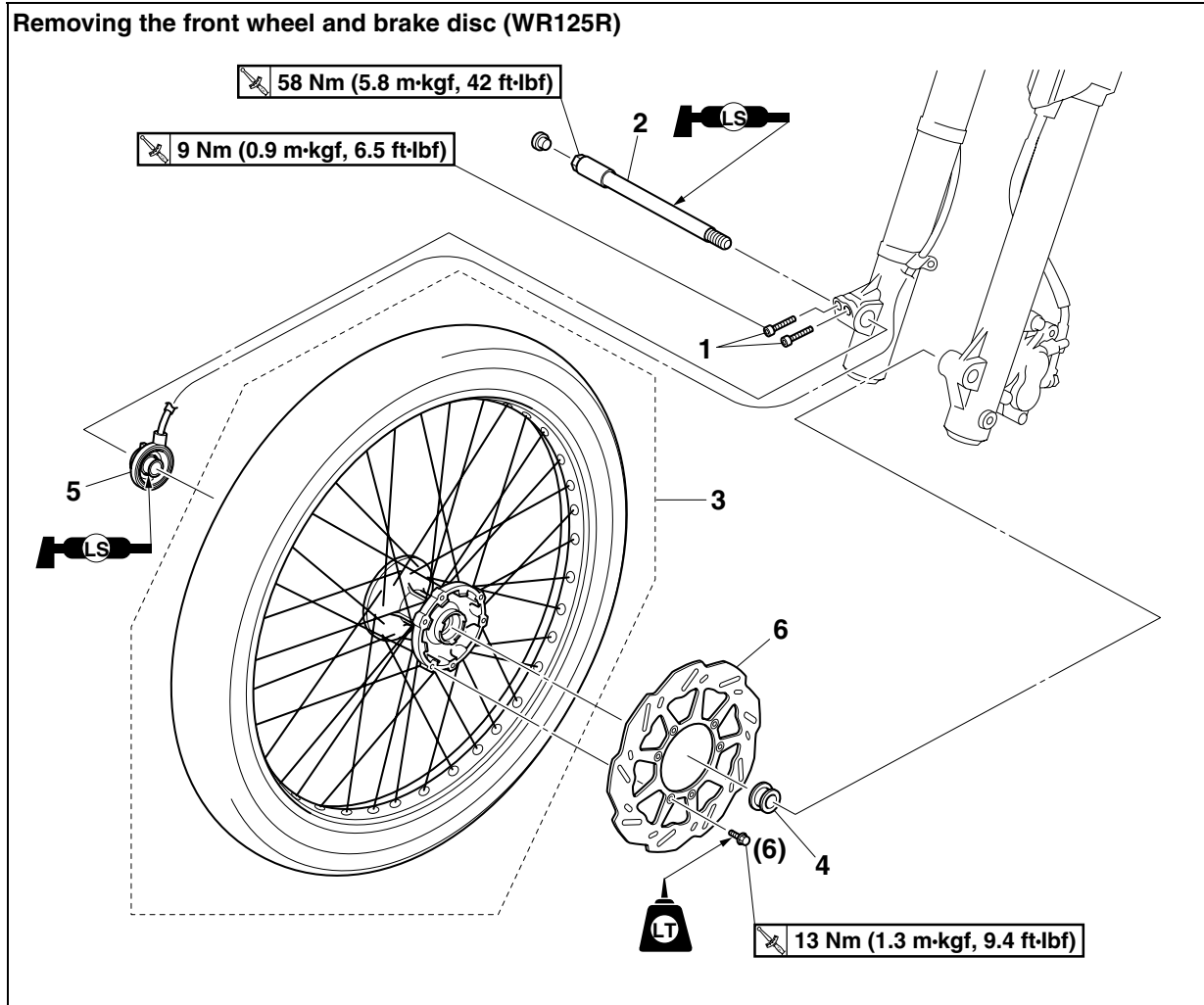

Order	Job/Parts to remove	Q'ty	Remarks
1	Front wheel axle pinch bolt	2	Loosen.
2	Front wheel axle	1	
3	Front wheel	1	
4	Collar	1	
5	Speed sensor	1	
6	Front brake disc	1	
			For installation, reverse the removal procedure.

Removing the front wheel and brake disc (WR125X)

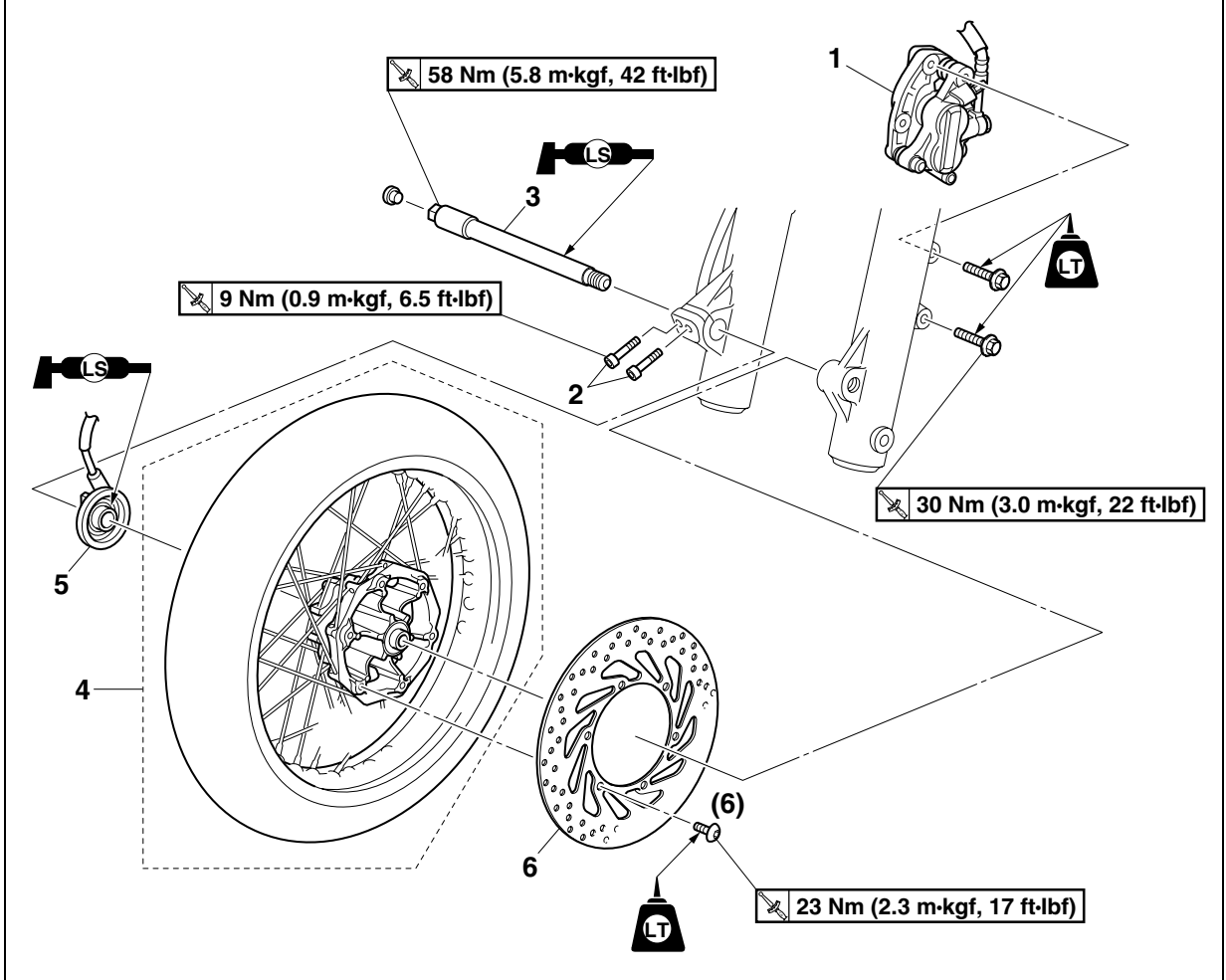

Order	Job/Parts to remove	Q'ty	Remarks
1	Front brake caliper	1	
2	Front wheel axle pinch bolt	2	Loosen.
3	Front wheel axle	1	
4	Front wheel	1	
5	Speed sensor	1	
6	Front brake disc	1	
			For installation, reverse the removal procedure.

Disassembling the front wheel (WR125R)

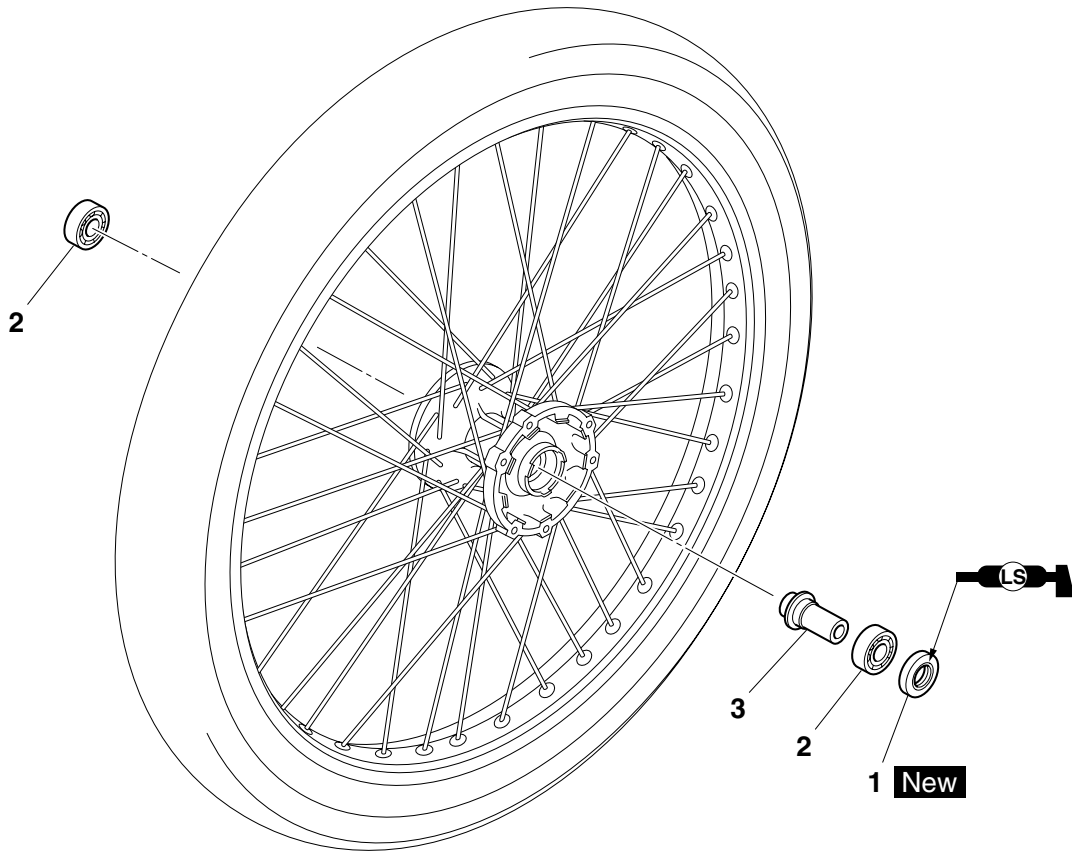

Order	Job/Parts to remove	Q'ty	Remarks
1	Oil seal	1	
2	Bearing	2	
3	Spacer	1	
			For assembly, reverse the disassembly procedure.

Disassembling the front wheel (WR125X)

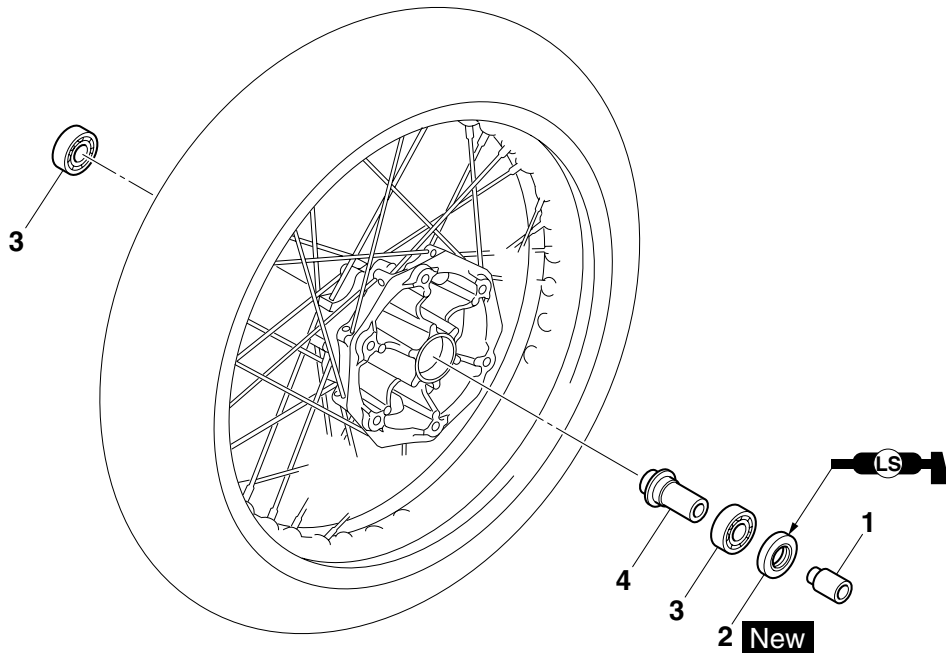

Order	Job/Parts to remove	Q'ty	Remarks
1	Collar	1	
2	Oil seal	1	
3	Bearing	2	
4	Spacer	1	
			For assembly, reverse the disassembly procedure.



EAS21890

### REMOVING THE FRONT WHEEL (DISC)

1. Stand the vehicle on a level surface.

EWA13120

#### **⚠ WARNING**

**Securely support the vehicle so that there is no danger of it falling over.**

2. Elevate:
  - Front wheel

#### TIP

Place the vehicle on a suitable stand so that the front wheel is elevated.

3. Remove:
  - Front brake caliper (WR125X)

#### TIP

Do not squeeze the brake lever when removing the front brake caliper.

4. Remove:
  - Collar (WR125R)

#### TIP

Do not disassemble the collar.

EAS21910

### DISASSEMBLING THE FRONT WHEEL

1. Remove:
  - Oil seal
  - Wheel bearings

- a. Clean the surface of the front wheel hub.
- b. Remove the oil seal "1" with a flat-head screwdriver.

#### TIP

To prevent damaging the wheel, place a rag "2" between the screwdriver and the wheel surface.

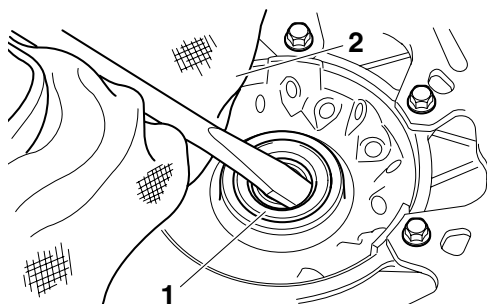

- c. Remove the wheel bearings "3" with a general bearing puller.

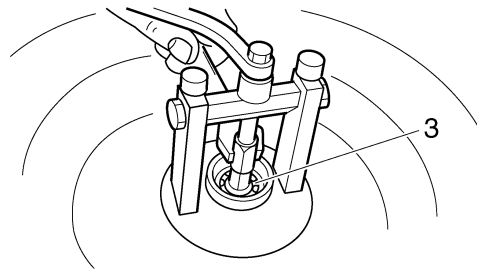

EAS21930

### CHECKING THE FRONT WHEEL

1. Check:
  - Wheel axle
    - Roll the wheel axle on a flat surface.
    - Bends → Replace.

EWA13460

#### **⚠ WARNING**

**Do not attempt to straighten a bent wheel axle.**

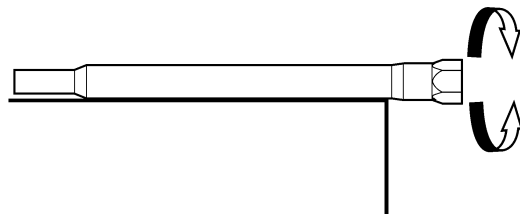

2. Check:
  - Tire
  - Front wheel
    - Damage/wear → Replace.
    - Refer to "CHECKING THE TIRES" on page 3-23 and "CHECKING THE WHEELS" on page 3-25.
3. Check:
  - Spokes
    - Bends/damage → Replace.
    - Loose → Tighten.
    - Refer to "CHECKING AND TIGHTENING THE SPOKES" on page 3-25.

#### TIP

After tightening the spokes, measure the front wheel runout.

4. Measure:
  - Wheel radial runout "1"
  - Wheel lateral runout "2"
  - Over the specified limits → Replace.



4. Measure:

- Collar "1" (WR125R)  
Out of specification → Adjust.



**Installed depth "a"**  
**8 mm (0.31 in)**

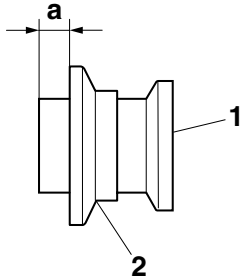

2. Dust cover

5. Install:

- Speed sensor

**TIP**

- Make sure that the speed sensor and the wheel hub are installed with the projection "a" on the wheel hub inserted in a slot "b" in the speed sensor.
- When installing the speed sensor, make sure that the projection on the wheel hub does not damage the lip of the speed sensor oil seal.

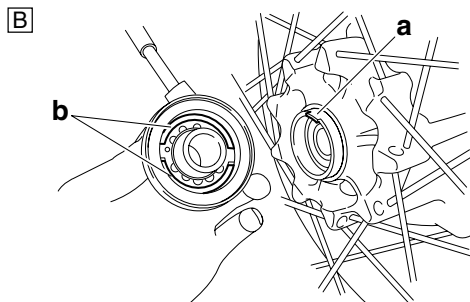
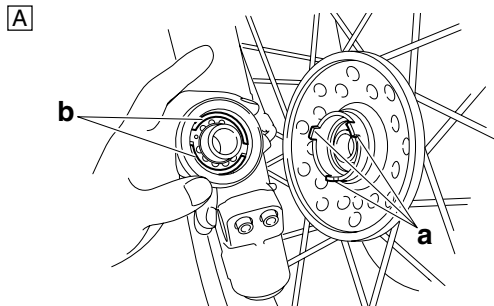

- A. WR125R
- B. WR125X

6. Install:

- Front wheel

**TIP**

Make sure that the projections "a" on the speed sensor fit over the stopper "b" on the outer tube.

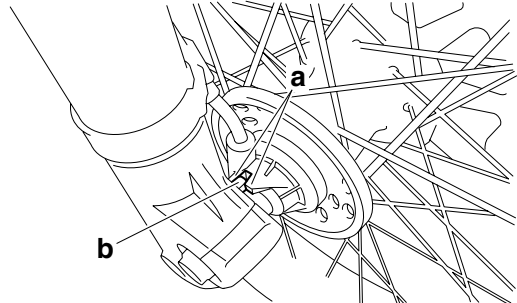

7. Tighten:

- Front wheel axle
- Front wheel axle pinch bolts



**Front wheel axle**  
**58 Nm (5.8 m·kgf, 42 ft·lbf)**  
**Front wheel axle pinch bolt**  
**9 Nm (0.9 m·kgf, 6.5 ft·lbf)**

EWA22B1004

**WARNING**

Make sure the speed sensor lead is routed properly.

ECA22B1023

**NOTICE**

Before tightening the wheel axle, push down hard on the handlebar several times and check if the front fork rebounds smoothly.

- a. Insert the front wheel axle from the right side of the vehicle and tighten it to specification.
- b. Tighten each bolt to specification in the order of pinch bolt "2" → pinch bolt "1" → pinch bolt "2" (or pinch bolt "1" → pinch bolt "2" → pinch bolt "1").

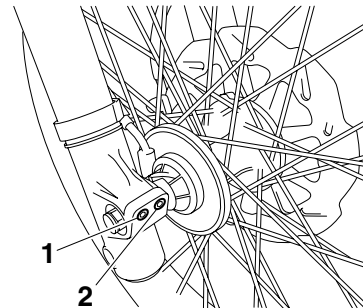

EAS22020

## REAR WHEEL

### Removing the rear wheel, rear brake disc, and rear wheel sprocket

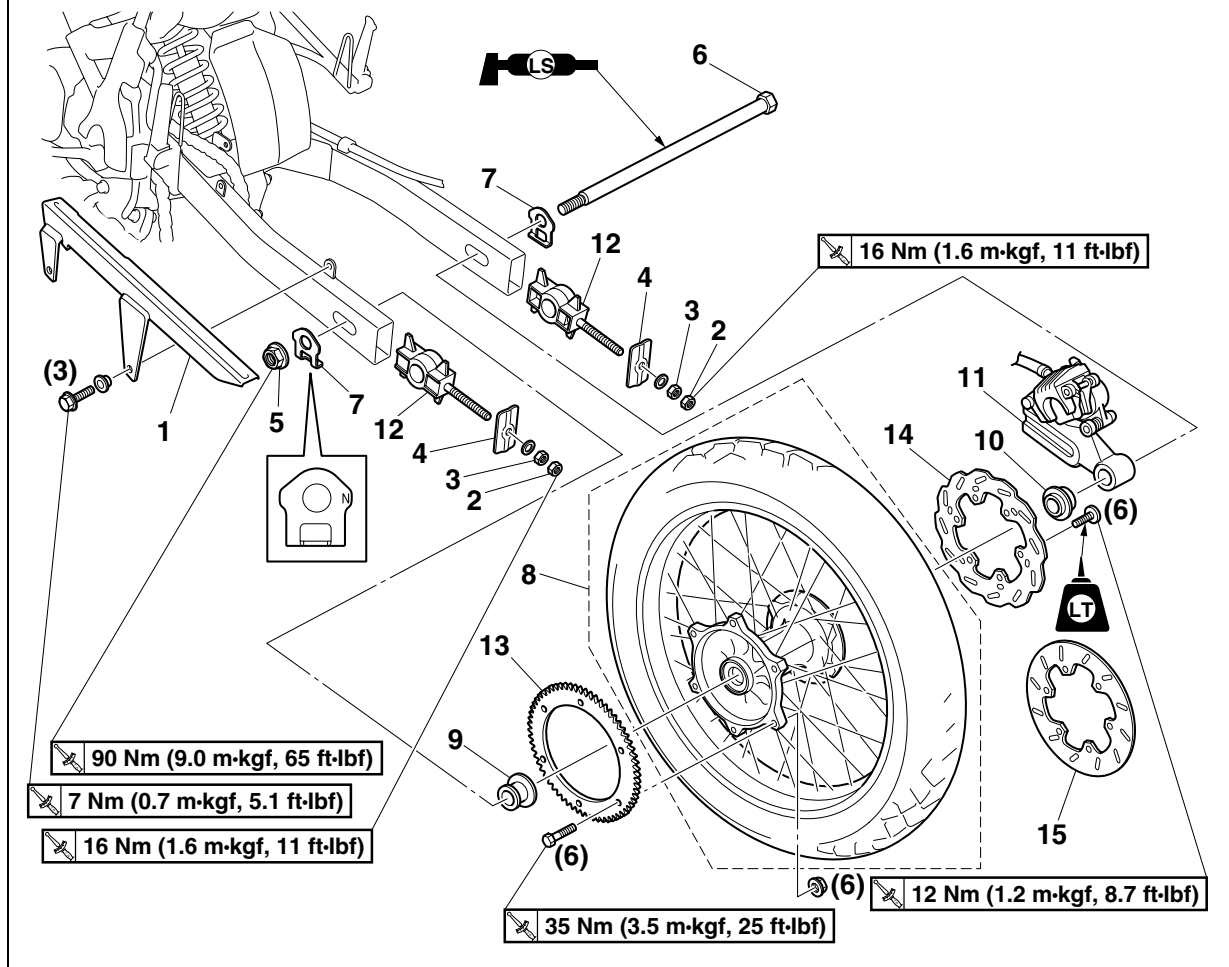

Order	Job/Parts to remove	Q'ty	Remarks
1	Drive chain guard	1	
2	Drive chain adjusting locknut	2	Green
3	Drive chain adjusting nut	2	Black
4	Swingarm end plate	2	
5	Rear wheel axle nut	1	
6	Rear wheel axle	1	
7	Drive chain alignment plate	2	
8	Rear wheel	1	
9	Collar with dust cover	1	
10	Collar with dust cover	1	
11	Brake caliper	1	
12	Chain puller	2	
13	Rear wheel sprocket	1	
14	Rear brake disc	1	WR125R

Removing the rear wheel, rear brake disc, and rear wheel sprocket

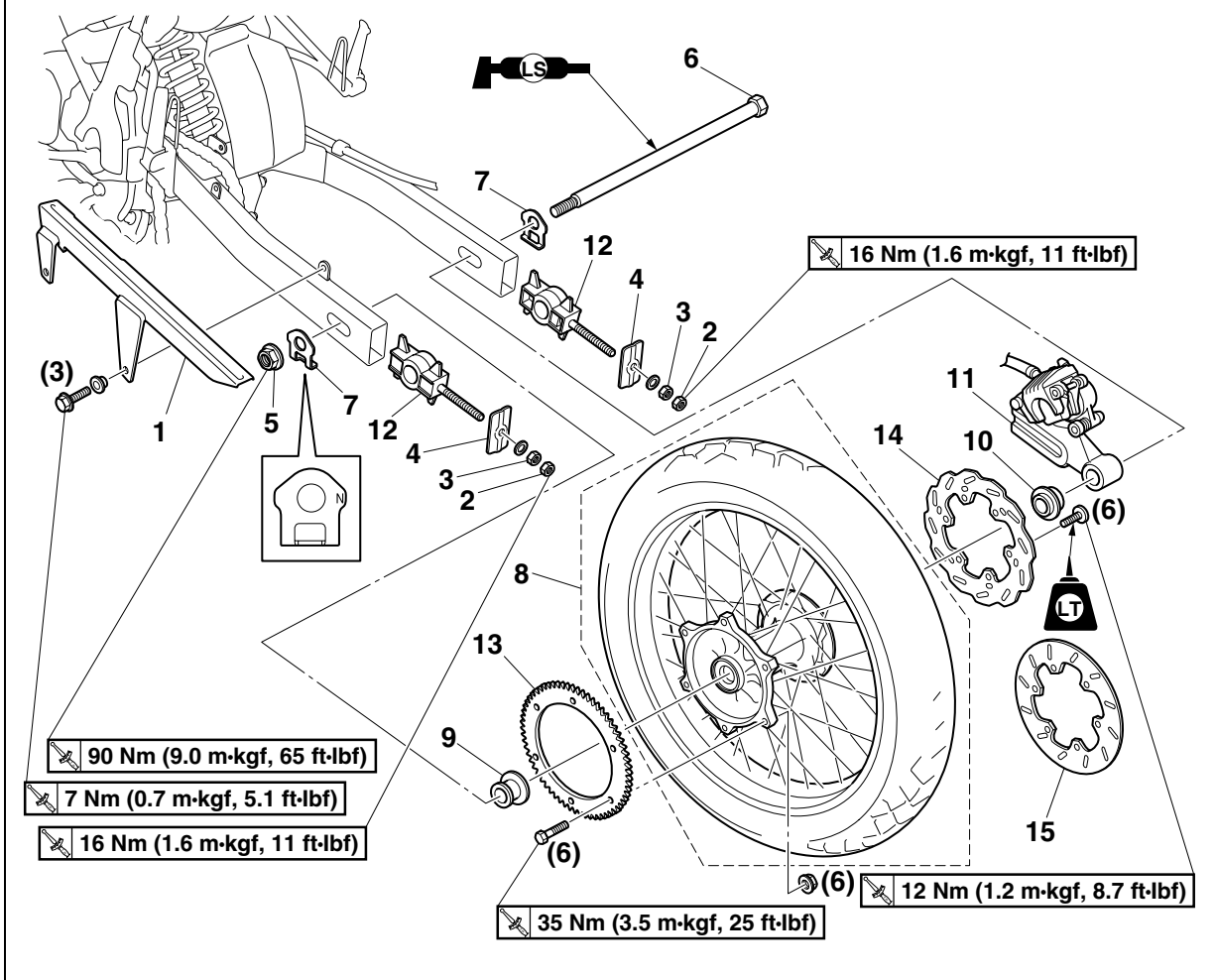

Order	Job/Parts to remove	Q'ty	Remarks
15	Rear brake disc	1	WR125X
			For installation, reverse the removal procedure.

Disassembling the rear wheel (WR125R)

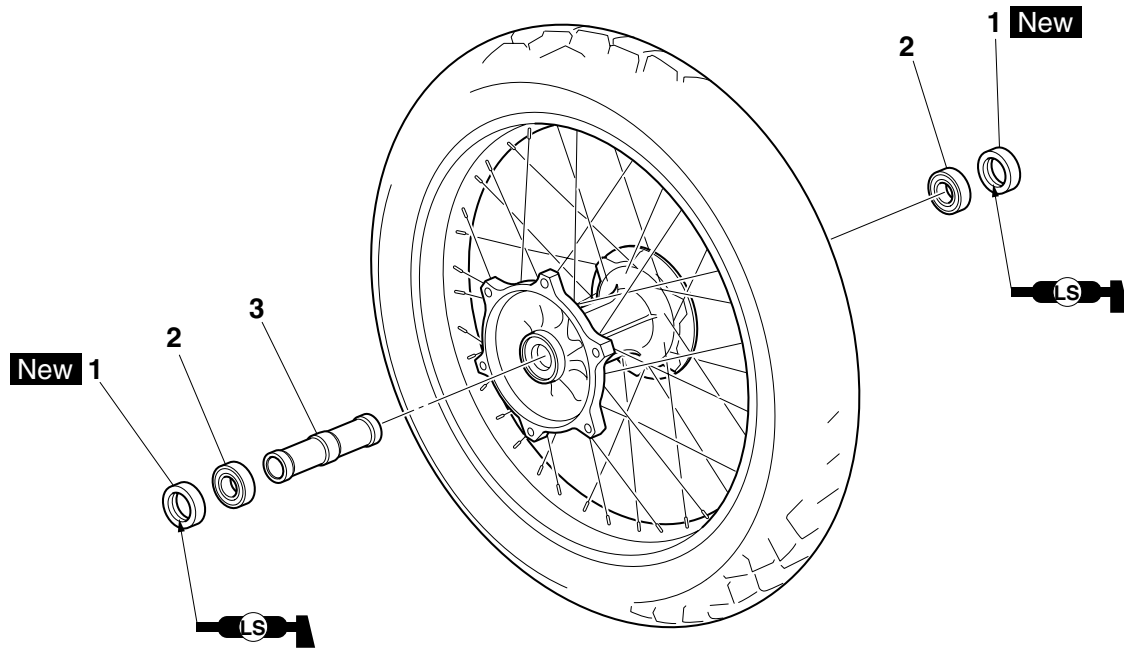

Order	Job/Parts to remove	Q'ty	Remarks
1	Oil seal	2	
2	Bearing	2	
3	Spacer	1	
			For assembly, reverse the disassembly procedure.

Disassembling the rear wheel (WR125X)

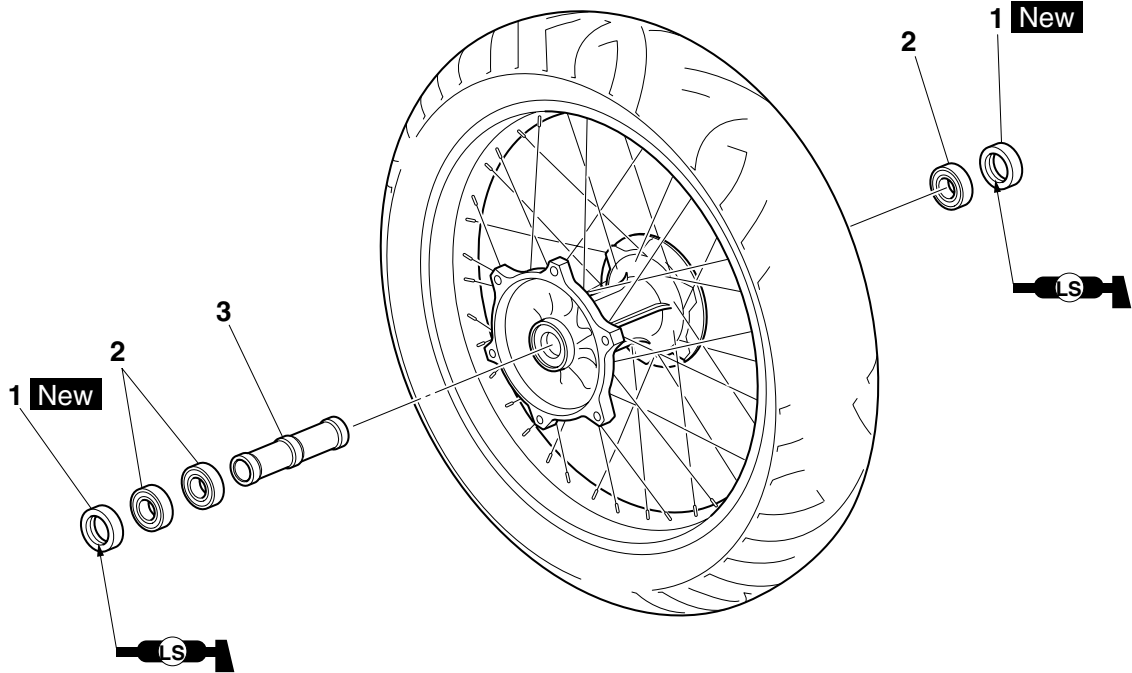

Order	Job/Parts to remove	Q'ty	Remarks
1	Oil seal	2	
2	Bearing	3	
3	Spacer	1	
			For assembly, reverse the disassembly procedure.

EAS22040

### REMOVING THE REAR WHEEL (DISC)

1. Stand the vehicle on a level surface.

EWA13120

**⚠ WARNING**

**Securely support the vehicle so that there is no danger of it falling over.**

**TIP**

Place the vehicle on a suitable stand so that the rear wheel is elevated.

2. Loosen:

- Drive chain adjusting locknut
- Drive chain adjusting nut

3. Remove:

- Rear wheel axle nut
- Rear wheel axle
- Drive chain alignment plate
- Rear wheel

**TIP**

Push the rear wheel forward and remove the drive chain from the rear wheel sprocket.

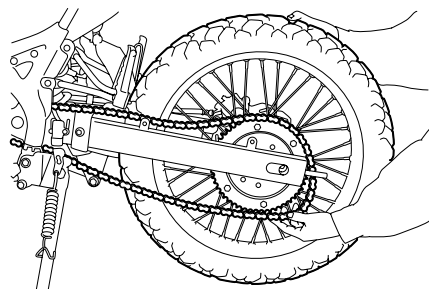

4. Remove:

- Rear brake caliper

**TIP**

Do not depress the brake pedal when removing the brake caliper.

EAS22080

### DISASSEMBLING THE REAR WHEEL

1. Remove:

- Oil seals
  - Wheel bearings
- Refer to “DISASSEMBLING THE FRONT WHEEL” on page 4-10.

EAS22100

### CHECKING THE REAR WHEEL

1. Check:

- Rear wheel axle
- Rear wheel
- Wheel bearings

• Oil seals

Refer to “CHECKING THE FRONT WHEEL” on page 4-10.

2. Check:

- Tire
  - Rear wheel
- Damage/wear → Replace.
- Refer to “CHECKING THE TIRES” on page 3-23 and “CHECKING THE WHEELS” on page 3-25.

3. Check:

- Spokes
- Refer to “CHECKING THE FRONT WHEEL” on page 4-10.

4. Measure:

- Radial wheel runout
  - Lateral wheel runout
- Refer to “CHECKING THE FRONT WHEEL” on page 4-10.

	<p><b>Radial wheel runout limit 1.0 mm (0.04 in)</b></p> <p><b>Lateral wheel runout limit 0.5 mm (0.02 in)</b></p>
--	--

EAS22120

### CHECKING AND REPLACING THE REAR WHEEL SPROCKET

1. Check:

- Rear wheel sprocket
- More than 1/4 tooth “a” wear → Replace the rear wheel sprocket.
- Bent teeth → Replace the rear wheel sprocket.

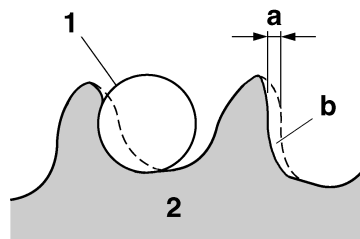

b. Correct

1. Drive chain roller
2. Rear wheel sprocket

2. Replace:

- Rear wheel sprocket



a. Remove the self-locking bolts, nuts, and the rear wheel sprocket.



- b. Clean the rear wheel drive hub with a clean cloth, especially the surfaces that contact the sprocket.
- c. Install the new rear wheel sprocket.

	<b>Rear wheel sprocket bolt</b> <b>35 Nm (3.5 m·kgf, 25 ft·lbf)</b>
---	--

**TIP**

Tighten the bolts in stages and in a crisscross pattern.

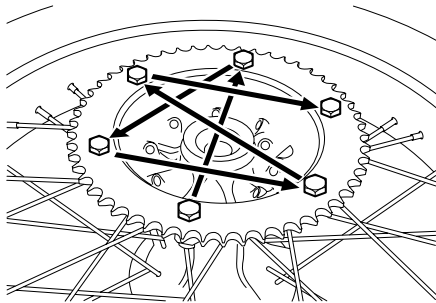

EAS22140

### ASSEMBLING THE REAR WHEEL

1. Install:
  - Wheel bearings
  - Oil seals **New**
 Refer to "ASSEMBLING THE FRONT WHEEL" on page 4-11.

EAS22160

### INSTALLING THE REAR WHEEL (DISC)

1. Install:
  - Rear brake disc

	<b>Rear brake disc bolt</b> <b>12 Nm (1.2 m·kgf, 8.7 ft·lbf)</b> <b>LOCTITE®</b>
---	--

**TIP**

- Be sure to install the rear brake disc with the arrow mark "a" on the disc facing out. (WR125R)
- Tighten the brake disc bolts in stages and in a crisscross pattern.

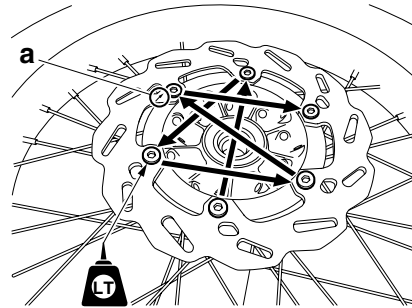

2. Check:
  - Rear brake disc  
Refer to "CHECKING THE REAR BRAKE DISC" on page 4-36.
3. Lubricate:
  - Rear wheel axle
  - Oil seal lips

	<b>Recommended lubricant</b> <b>Lithium-soap-based grease</b>
---	--

4. Adjust:
  - Drive chain slack  
Refer to "ADJUSTING THE DRIVE CHAIN SLACK" on page 3-20.

	<b>Drive chain slack</b> <b>40.0–50.0 mm (1.57–1.97 in)</b>
---	--

ECA13550

**NOTICE**

**A drive chain that is too tight will overload the engine and other vital parts, and one that is too loose can skip and damage the swing-arm or cause an accident. Therefore, keep the drive chain slack within the specified limits.**

EAS22210

## FRONT BRAKE

### Removing the front brake pads

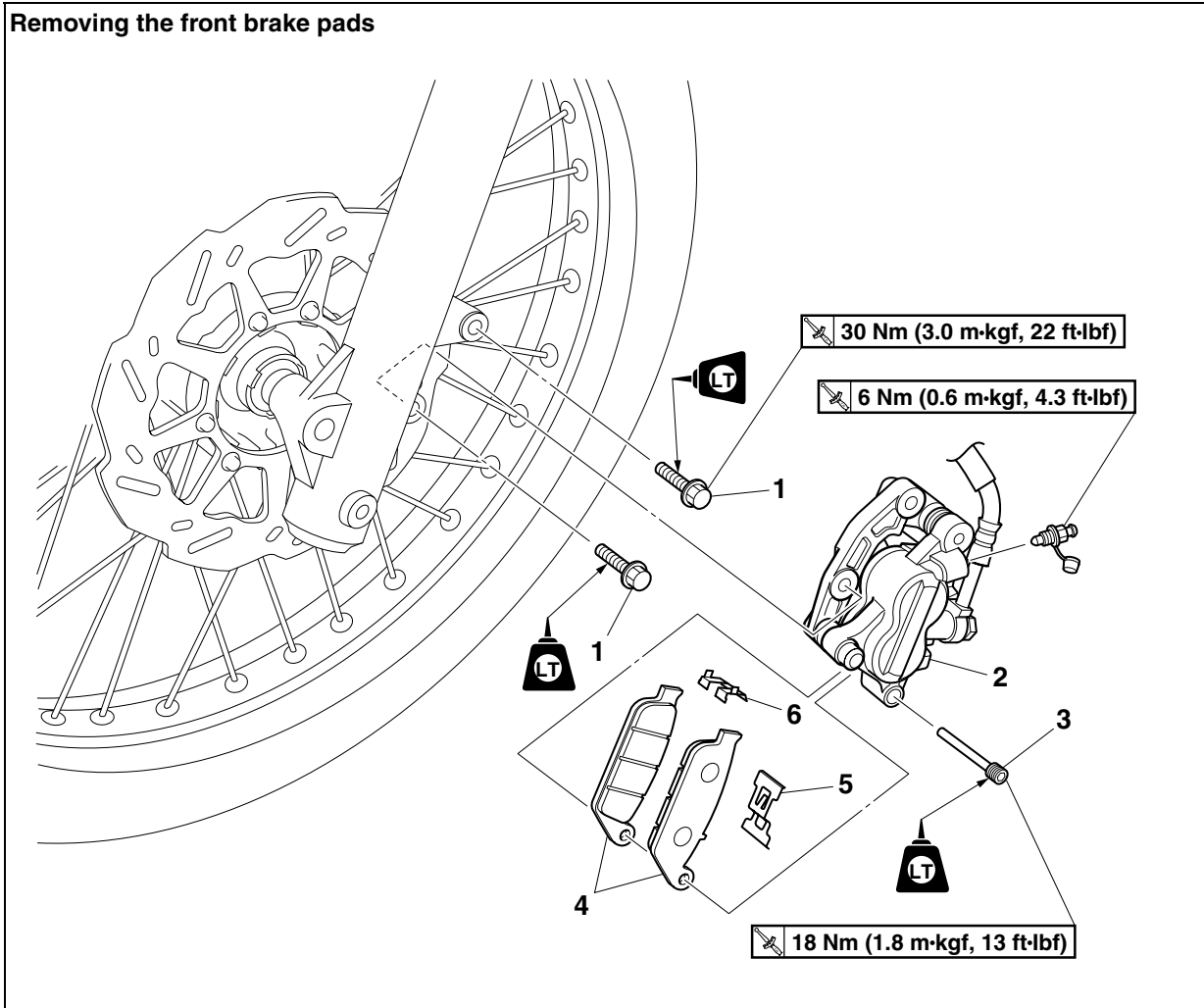

Order	Job/Parts to remove	Q'ty	Remarks
1	Front brake caliper bolt	2	
2	Front brake caliper	1	
3	Brake pad pin	1	
4	Front brake pad	2	
5	Brake pad spring	1	
6	Brake pad support	1	
			For installation, reverse the removal procedure.

Removing the front brake master cylinder

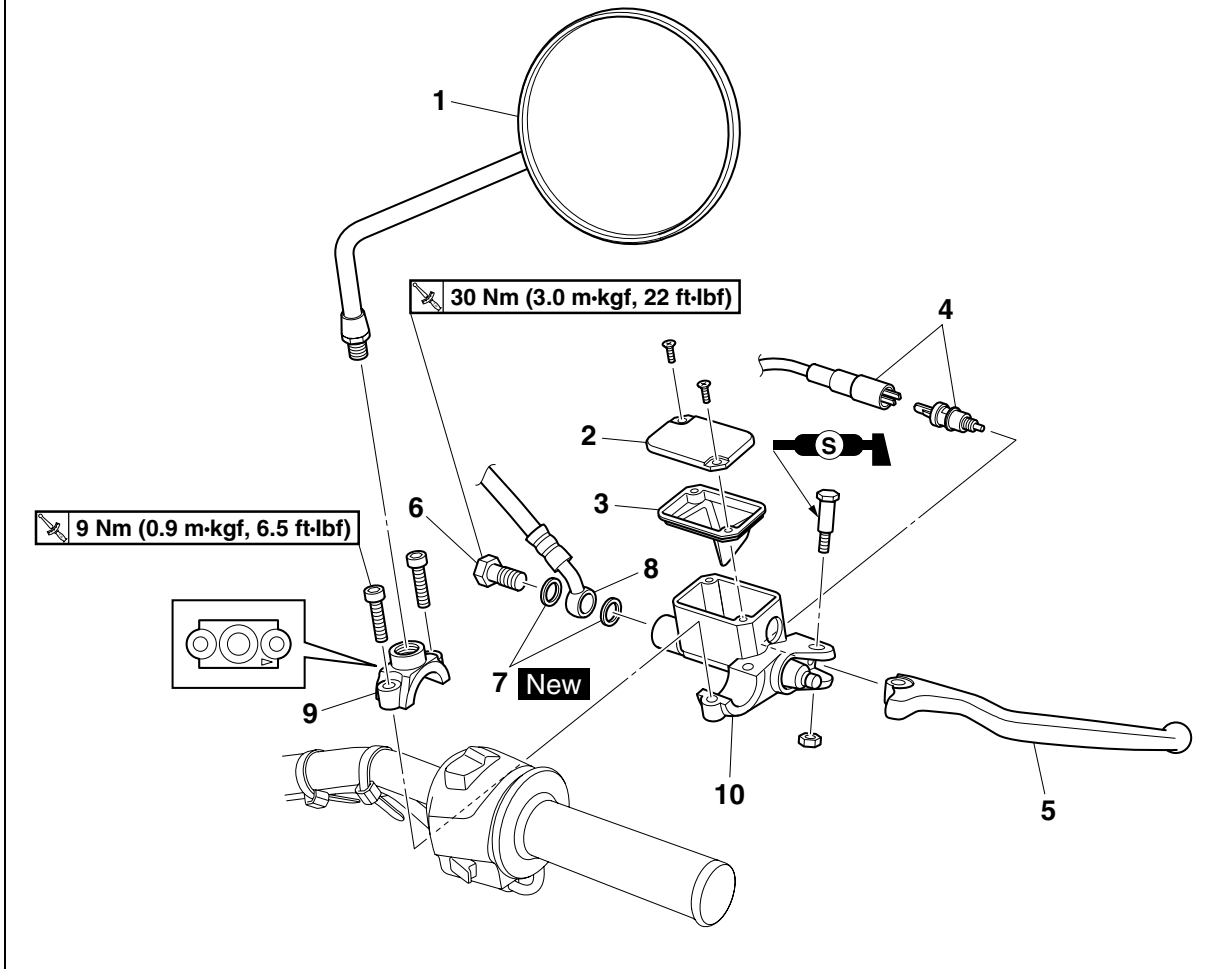

Order	Job/Parts to remove	Q'ty	Remarks
	Brake fluid		Drain. Refer to "BLEEDING THE HYDRAULIC BRAKE SYSTEM" on page 3-19.
1	Right rearview mirror	1	
2	Brake master cylinder reservoir cap	1	
3	Brake master cylinder reservoir diaphragm	1	
4	Front brake light switch	1	
5	Brake lever	1	
6	Brake hose union bolt	1	
7	Copper washer	2	
8	Front brake hose	1	
9	Front brake master cylinder holder	1	
10	Front brake master cylinder	1	
			For installation, reverse the removal procedure.

Removing the front brake caliper

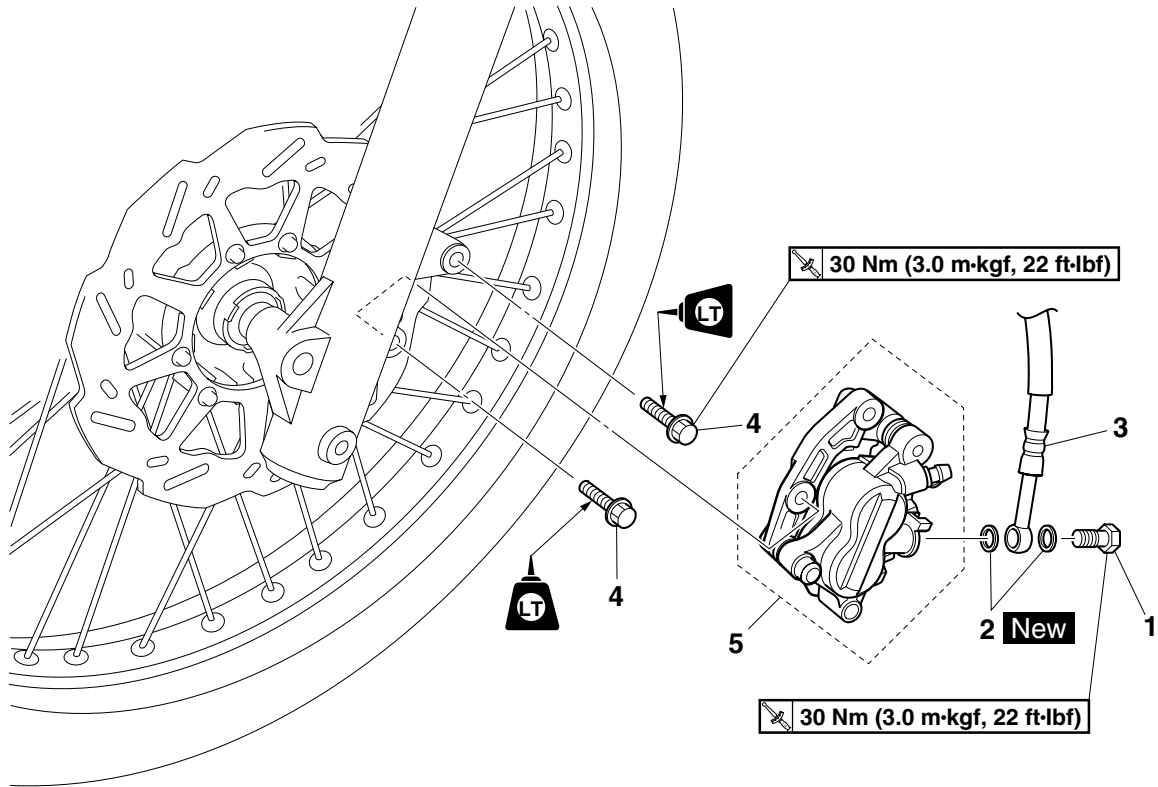

Order	Job/Parts to remove	Q'ty	Remarks
	Brake fluid		Drain. Refer to "BLEEDING THE HYDRAULIC BRAKE SYSTEM" on page 3-19.
1	Brake hose union bolt	1	
2	Copper washer	2	
3	Front brake hose	1	
4	Front brake caliper bolt	2	
5	Front brake caliper	1	
			For installation, reverse the removal procedure.

Disassembling the front brake caliper

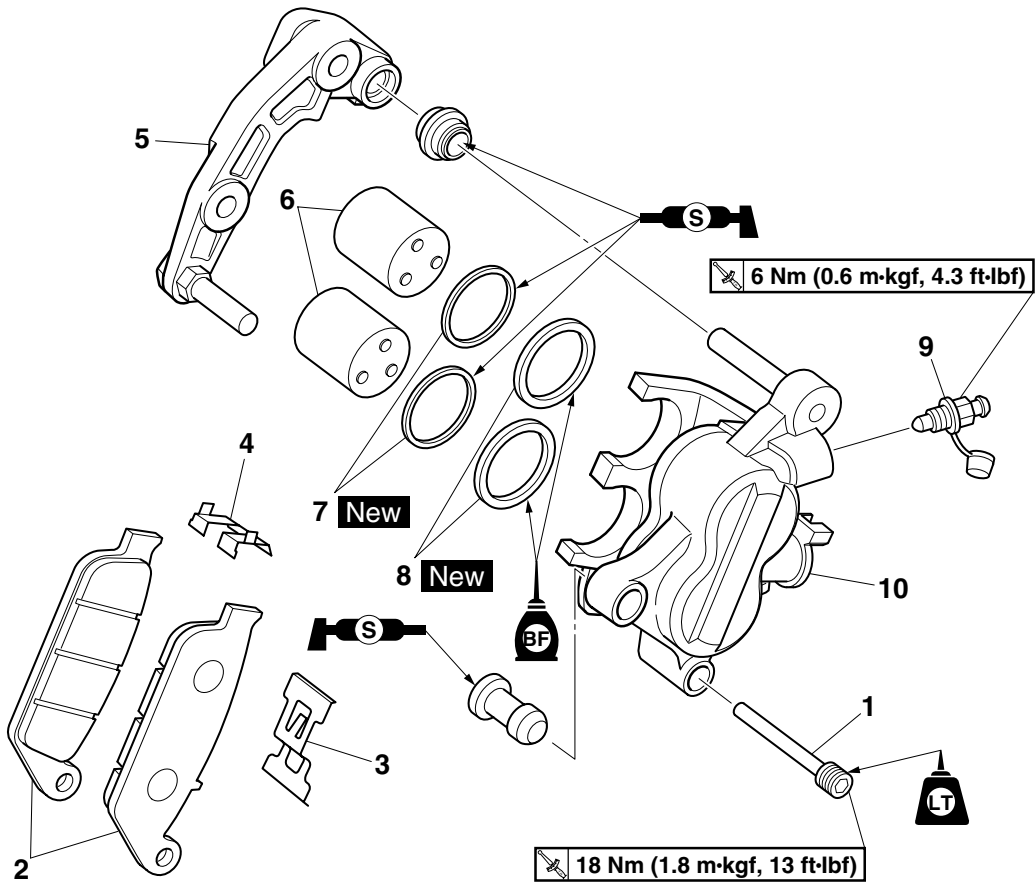

Order	Job/Parts to remove	Q'ty	Remarks
1	Brake pad pin	1	
2	Front brake pad	2	
3	Brake pad spring	1	
4	Brake pad support	1	
5	Front brake caliper bracket	1	
6	Brake caliper piston	2	
7	Brake caliper piston dust seal	2	
8	Brake caliper piston seal	2	
9	Bleed screw	1	
10	Brake caliper body	1	
			For assembly, reverse the disassembly procedure.

EAS22220

### INTRODUCTION

EWA14100



Disc brake components rarely require disassembly. Therefore, always follow these preventive measures:

- Never disassemble brake components unless absolutely necessary.
- If any connection on the hydraulic brake system is disconnected, the entire brake system must be disassembled, drained, cleaned, properly filled, and bled after reassembly.
- Never use solvents on internal brake components.
- Use only clean or new brake fluid for cleaning brake components.
- Brake fluid may damage painted surfaces and plastic parts. Therefore, always clean up any spilt brake fluid immediately.
- Avoid brake fluid coming into contact with the eyes as it can cause serious injury.
- **FIRST AID FOR BRAKE FLUID ENTERING THE EYES:**
- Flush with water for 15 minutes and get immediate medical attention.

- e. Measure the deflection 1.5 mm (0.06 in) (WR125R) or 2.0 mm (0.09 in) (WR125X) below the edge of the brake disc.

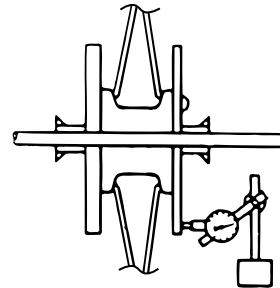

4. Measure:
  - Brake disc thickness
 Measure the brake disc thickness at a few different locations.  
 Out of specification → Replace.

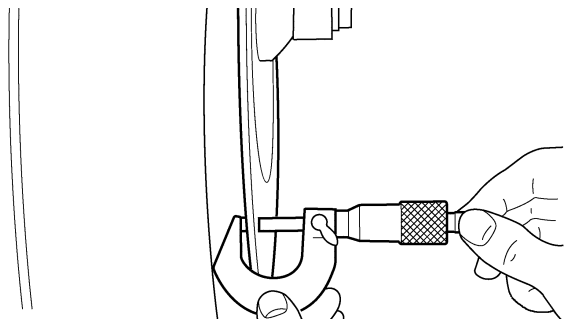

EAS22230

### CHECKING THE FRONT BRAKE DISC

1. Remove:
  - Front wheel  
Refer to "FRONT WHEEL" on page 4-6.
2. Check:
  - Brake disc  
Damage/galling → Replace.
3. Measure:
  - Brake disc deflection  
Out of specification → Correct the brake disc deflection or replace the brake disc.



**Brake disc deflection limit**  
0.15 mm (0.0059 in)

- a. Place the vehicle on a suitable stand so that the front wheel is elevated.
- b. Before measuring the front brake disc deflection, turn the handlebar to the left or right to ensure that the front wheel is stationary.
- c. Remove the brake caliper.
- d. Hold the dial gauge at a right angle against the brake disc surface.



**Brake disc thickness limit**  
WR125R 3.5 mm (0.14 in)  
WR125X 4.0 mm (0.16 in)

5. Adjust:
  - Brake disc deflection



- a. Remove the brake disc.
- b. Rotate the brake disc by one bolt hole.
- c. Install the brake disc.



**Brake disc bolt**  
WR125R  
13 Nm (1.3 m·kgf, 9.4 ft·lbf)  
LOCTITE®  
WR125X  
23 Nm (2.3 m·kgf, 17 ft·lbf)  
LOCTITE®

#### TIP

Tighten the brake disc bolts in stages and in a crisscross pattern.

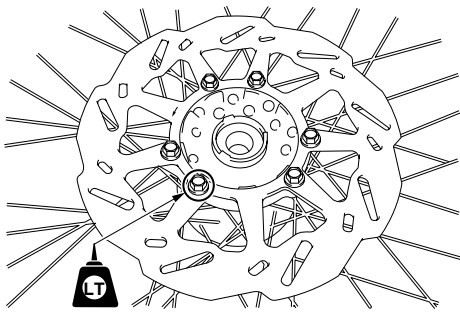

- d. Measure the brake disc deflection.
- e. If out of specification, repeat the adjustment steps until the brake disc deflection is within specification.
- f. If the brake disc deflection cannot be brought within specification, replace the brake disc.



- 6. Install:
  - Front wheel
 Refer to "FRONT WHEEL" on page 4-6.

EAS22270

## REPLACING THE FRONT BRAKE PADS

### TIP

When replacing the brake pads, it is not necessary to disconnect the brake hose or disassemble the brake caliper.

- 1. Measure:
  - Brake pad wear limit "a"
 Out of specification → Replace the brake pads as a set.

	<b>Brake pad lining thickness (inner)</b>
	5.0 mm (0.20 in)
	<b>Limit</b>
	1.0 mm (0.04 in)
	<b>Brake pad lining thickness (outer)</b>
	5.0 mm (0.20 in)
	<b>Limit</b>
	1.0 mm (0.04 in)

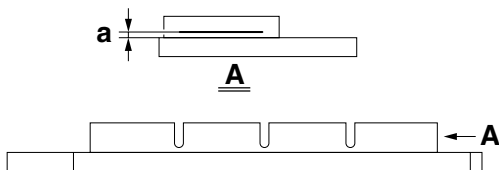

- 2. Install:
  - Brake pads
  - Brake pad spring
  - Brake pad support

### TIP

Always install new brake pads, a new brake pad spring, and a new brake pad support as a set.

- a. Connect a clear plastic hose "1" tightly to the bleed screw "2". Put the other end of the hose into an open container.

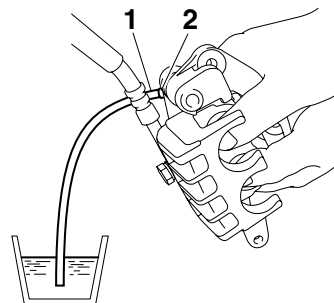

- b. Loosen the bleed screw and push the brake caliper pistons into the brake caliper with your fingers.
- c. Tighten the bleed screw.



**Front brake caliper bleed screw  
6 Nm (0.6 m·kgf, 4.3 ft·lbf)**

- d. Install new brake pads, a new brake pad spring, and a new brake pad support.

### TIP

The arrow mark "a" on the brake pad support must point in the direction shown in the illustration.

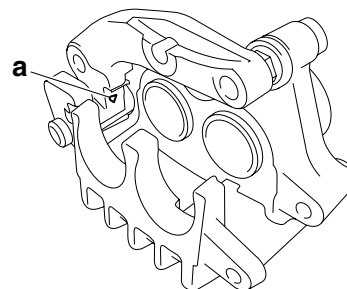

- 3. Install:
  - Brake pad pin
  - Front brake caliper
  - Front brake caliper bolts





- Brake caliper cylinders "2"  
Scratches/wear → Replace the brake caliper assembly.
- Brake caliper body "3"  
Cracks/damage → Replace the brake caliper assembly.
- Brake fluid delivery passages (brake caliper body)  
Obstruction → Blow out with compressed air.

EWA22B1005

**WARNING**

Whenever a brake caliper is disassembled, replace the brake caliper piston dust seals and brake caliper piston seals.

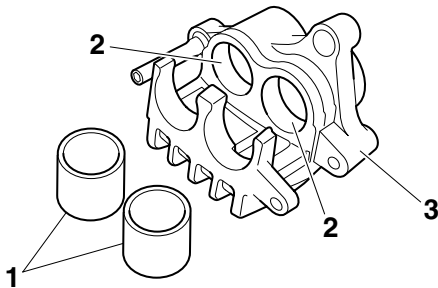

2. Check:
  - Front brake caliper bracket  
Cracks/damage → Replace.

EAS22400

### ASSEMBLING THE FRONT BRAKE CALIPER

EWA22B1006

**WARNING**

- Before installation, all internal brake components should be cleaned and lubricated with clean or new brake fluid.
- Never use solvents on internal brake components as they will cause the brake caliper piston dust seals and brake caliper piston seals to swell and distort.
- Whenever a brake caliper is disassembled, replace the brake caliper piston dust seals and brake caliper piston seals.



**Recommended fluid  
DOT 4**

EAS22420

### INSTALLING THE FRONT BRAKE CALIPER

1. Install:
  - Front brake caliper "1"  
(temporarily)
  - Copper washers **New**
  - Front brake hose "2"

- Brake hose union bolt "3"



**Front brake caliper bolt  
30 Nm (3.0 m·kgf, 22 ft·lbf)  
Brake hose union bolt  
30 Nm (3.0 m·kgf, 22 ft·lbf)**

EWA13530

**WARNING**

Proper brake hose routing is essential to insure safe vehicle operation. Refer to "CABLE ROUTING" on page 2-35.

ECA14170

**NOTICE**

When installing the brake hose onto the brake caliper "1", make sure the brake pipe "a" touches the projection "b" on the brake caliper.

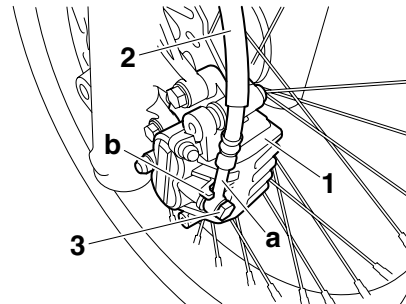

2. Remove:
  - Brake caliper
3. Install:
  - Brake pads
  - Brake pad spring
  - Brake pad support
  - Brake pad pin
  - Front brake caliper



**Brake pad pin  
18 Nm (1.8 m·kgf, 13 ft·lbf)  
LOCTITE®  
Front brake caliper bolt  
30 Nm (3.0 m·kgf, 22 ft·lbf)  
LOCTITE®**

Refer to "REPLACING THE FRONT BRAKE PADS" on page 4-24.

4. Fill:
  - Brake master cylinder reservoir  
(with the specified amount of the recommended brake fluid)



**Recommended fluid  
DOT 4**

EWA13540

**WARNING**

- Use only the designated brake fluid. Other brake fluids may cause the rubber seals to deteriorate, causing leakage and poor brake performance.
- Refill with the same type of brake fluid that is already in the system. Mixing brake fluids may result in a harmful chemical reaction, leading to poor brake performance.
- When refilling, be careful that water does not enter the brake master cylinder reservoir. Water will significantly lower the boiling point of the brake fluid and could cause vapor lock.

ECA13540

**NOTICE**

Brake fluid may damage painted surfaces and plastic parts. Therefore, always clean up any spilt brake fluid immediately.

- Bleed:
  - Brake system  
Refer to "BLEEDING THE HYDRAULIC BRAKE SYSTEM" on page 3-19.
- Check:
  - Brake fluid level  
Below the minimum level mark "a" → Add the recommended brake fluid to the proper level. Refer to "CHECKING THE BRAKE FLUID LEVEL" on page 3-17.

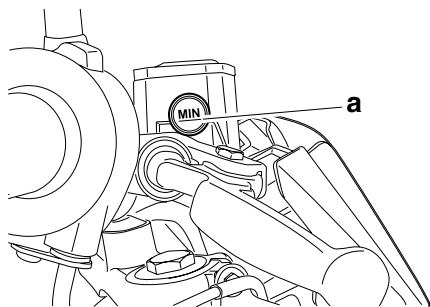

- Check:
  - Brake lever operation  
Soft or spongy feeling → Bleed the brake system.  
Refer to "BLEEDING THE HYDRAULIC BRAKE SYSTEM" on page 3-19.

EAS22490

**REMOVING THE FRONT BRAKE MASTER CYLINDER****TIP**

Before removing the front brake master cylinder, drain the brake fluid from the entire brake system.

- Remove:
  - Front brake light switch

**TIP**

The front brake light switch is a screw-type switch. Unscrew the switch to remove it from the brake master cylinder.

- Remove:
  - Brake hose union bolt
  - Copper washers
  - Front brake hose

**TIP**

To collect any remaining brake fluid, place a container under the master cylinder and the end of the brake hose.

EAS22500

**CHECKING THE FRONT BRAKE MASTER CYLINDER**

- Check:
  - Brake master cylinder  
Damage/scratches/wear → Replace.
  - Brake fluid delivery passages (brake master cylinder body)  
Obstruction → Blow out with compressed air.
- Check:
  - Brake master cylinder reservoir  
Cracks/damage → Replace.
  - Brake master cylinder reservoir diaphragm  
Damage/wear → Replace.
- Check:
  - Brake hose  
Cracks/damage/wear → Replace.

EAS22530

**INSTALLING THE FRONT BRAKE MASTER CYLINDER**

- Install:
  - Front brake master cylinder "1"
  - Front brake master cylinder holder "2"



**Front brake master cylinder holder bolt**  
9 Nm (0.9 m·kgf, 6.5 ft·lbf)

### TIP

- Install the brake master cylinder holder with the arrow mark “a” pointing forward.
- Align the end of the brake master cylinder holder with the punch mark “b” on the handlebar.
- First, tighten the front bolt, then the rear bolt.

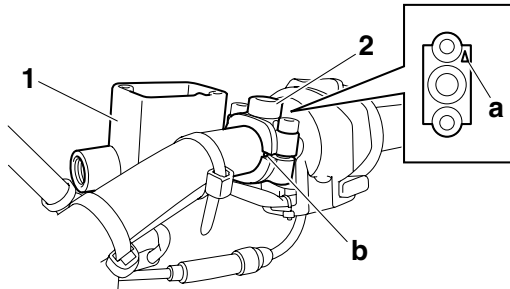

### 2. Install:

- Copper washers **New**
- Front brake hose
- Brake hose union bolt

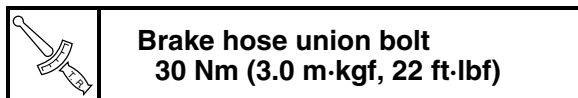

EWA13530

### WARNING

Proper brake hose routing is essential to insure safe vehicle operation. Refer to “CABLE ROUTING” on page 2-35.

### TIP

- Install the brake hose to the front brake master cylinder within the angle shown in the illustration.
- While holding the brake hose, tighten the union bolt.
- Turn the handlebar to the left and right to make sure the brake hose does not touch other parts (e.g., wire harness, cables, leads). Correct if necessary.

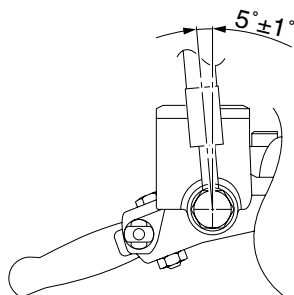

### 3. Fill:

- Brake master cylinder reservoir (with the specified amount of the recommended brake fluid)



ECA13540

### WARNING

- Use only the designated brake fluid. Other brake fluids may cause the rubber seals to deteriorate, causing leakage and poor brake performance.
- Refill with the same type of brake fluid that is already in the system. Mixing brake fluids may result in a harmful chemical reaction, leading to poor brake performance.
- When refilling, be careful that water does not enter the brake master cylinder reservoir. Water will significantly lower the boiling point of the brake fluid and could cause vapor lock.

ECA13540

### NOTICE

Brake fluid may damage painted surfaces and plastic parts. Therefore, always clean up any spilt brake fluid immediately.

### 4. Bleed:

- Brake system  
Refer to “BLEEDING THE HYDRAULIC BRAKE SYSTEM” on page 3-19.

### 5. Check:

- Brake fluid level  
Below the minimum level mark “a” → Add the recommended brake fluid to the proper level. Refer to “CHECKING THE BRAKE FLUID LEVEL” on page 3-17.

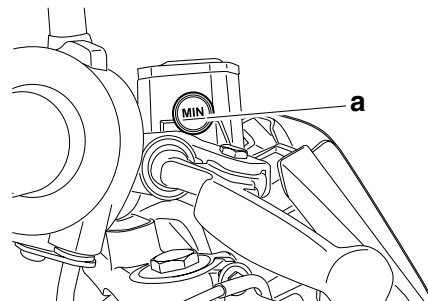

### 6. Check:

- Brake lever operation  
Soft or spongy feeling → Bleed the brake system.

Refer to "BLEEDING THE HYDRAULIC BRAKE SYSTEM" on page 3-19.

EAS22550

**REAR BRAKE**

**Removing the rear brake pads**

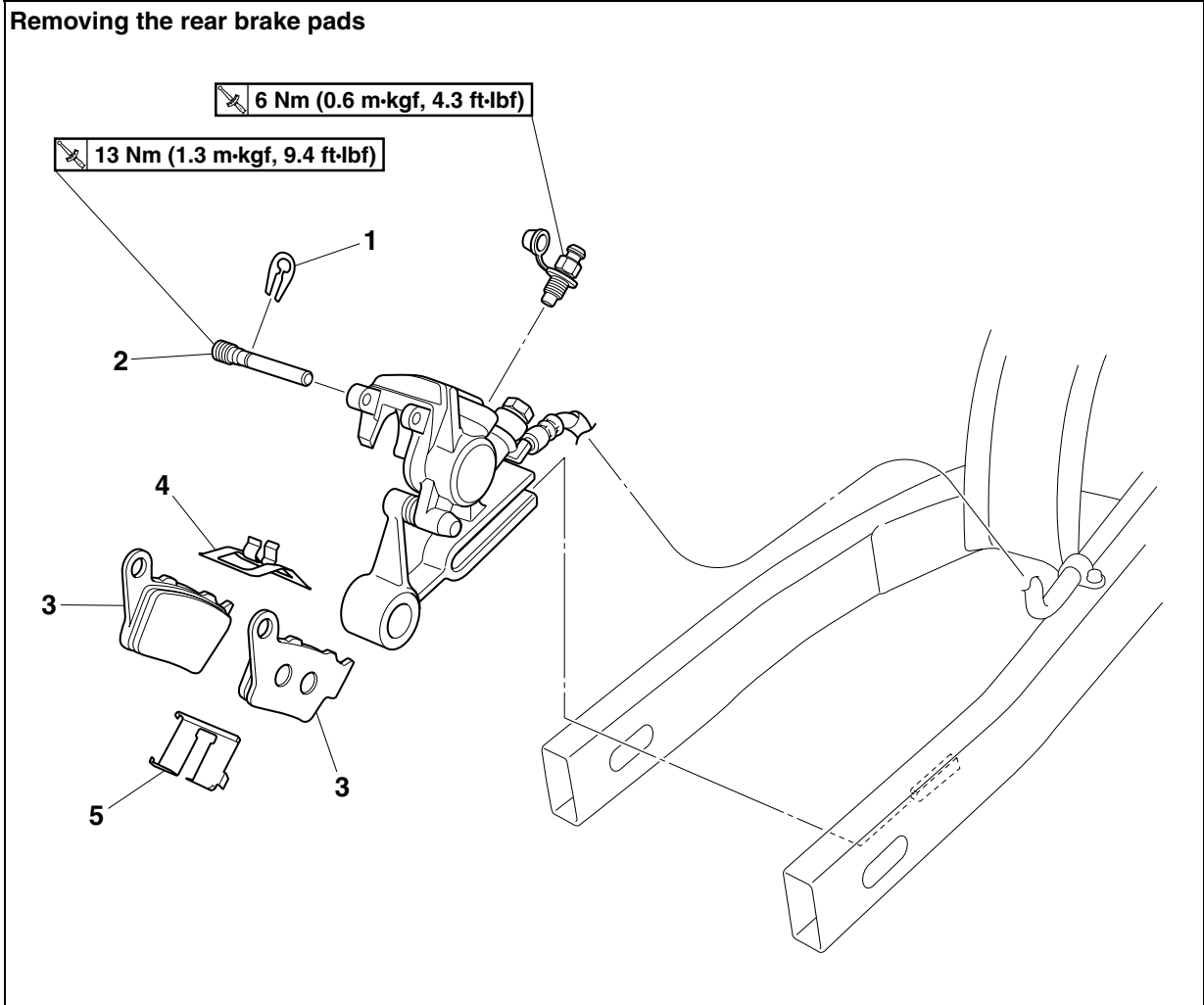

Order	Job/Parts to remove	Q'ty	Remarks
	Rear wheel		Refer to "REAR WHEEL" on page 4-13.
1	Brake pad clip	1	
2	Brake pad pin	1	
3	Rear brake pad	2	
4	Brake pad spring	1	
5	Brake pad support	1	
			For installation, reverse the removal procedure.

Removing the rear brake master cylinder

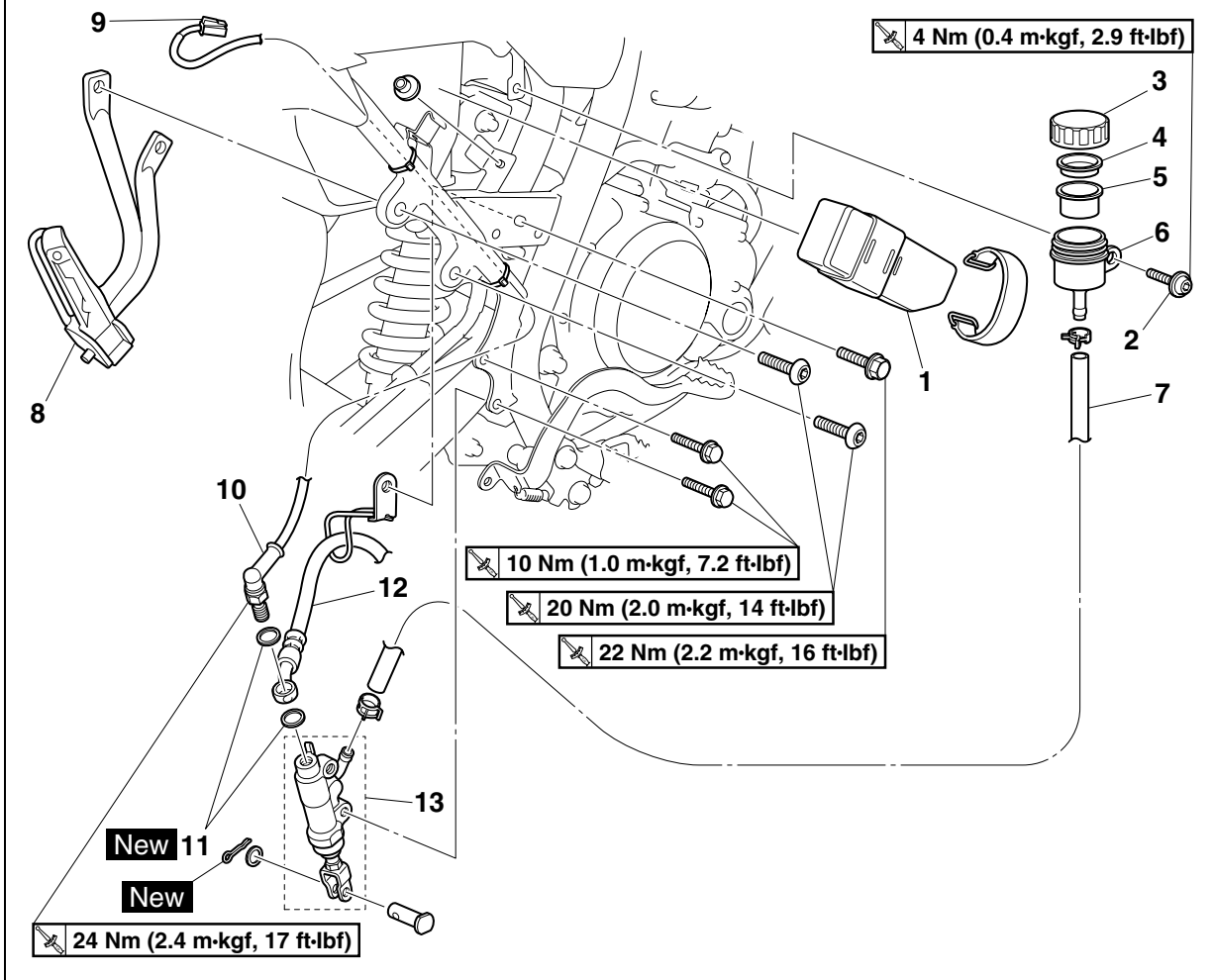

Order	Job/Parts to remove	Q'ty	Remarks
	Brake fluid		Drain. Refer to "BLEEDING THE HYDRAULIC BRAKE SYSTEM" on page 3-19.
	Right side cover/Right side panel		Refer to "GENERAL CHASSIS" on page 4-1.
1	Owner's tool kit	1	
2	Brake fluid reservoir bolt	1	
3	Brake fluid reservoir cap	1	
4	Brake fluid reservoir diaphragm holder	1	
5	Brake fluid reservoir diaphragm	1	
6	Brake fluid reservoir	1	
7	Brake fluid reservoir hose	1	
8	Right passenger footrest assembly	1	
9	Rear brake light switch coupler	1	Disconnect.
10	Rear brake light switch	1	
11	Copper washer	2	
12	Rear brake hose	1	

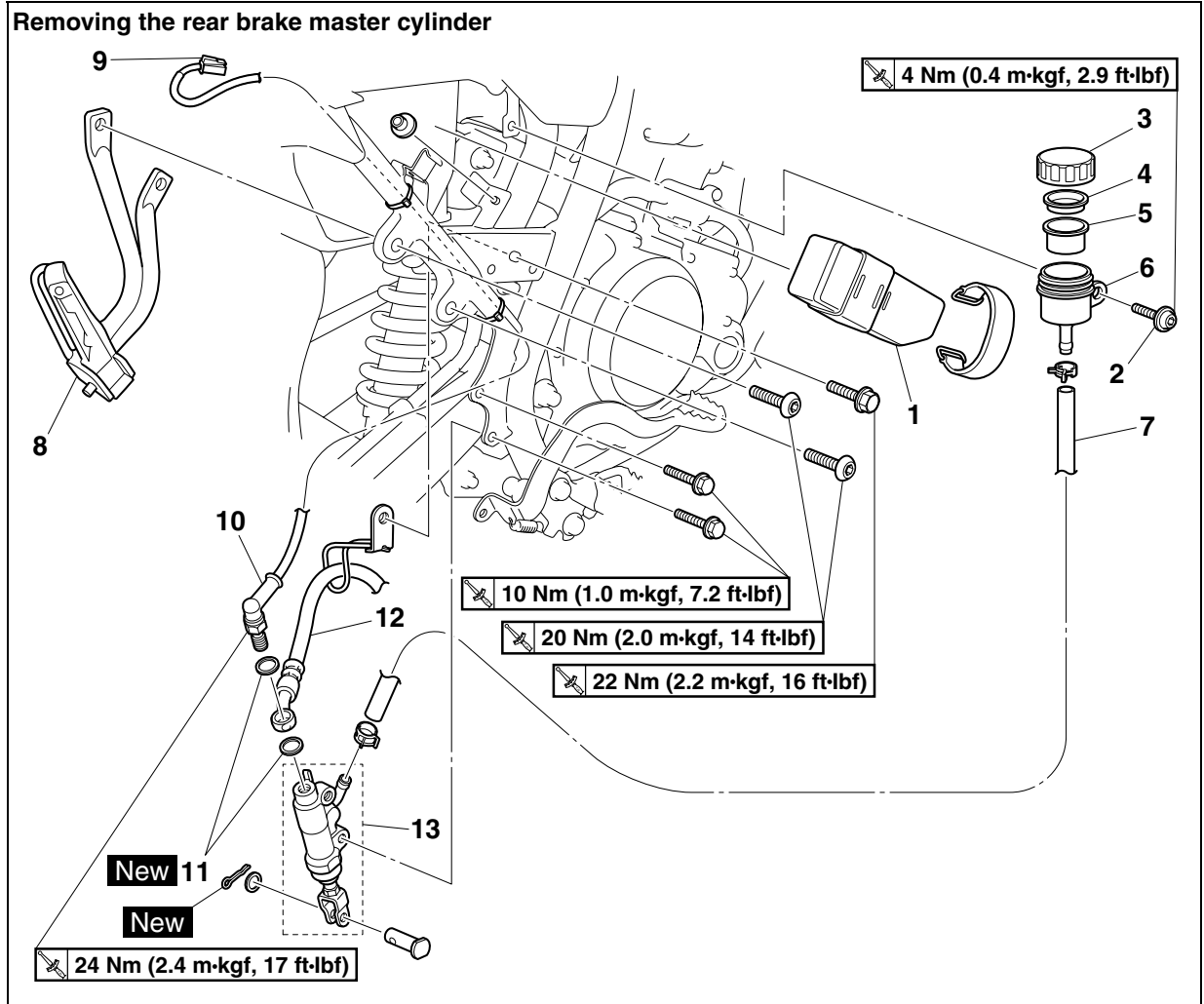

Order	Job/Parts to remove	Q'ty	Remarks
13	Rear brake master cylinder	1	
			For installation, reverse the removal procedure.

Disassembling the rear brake master cylinder

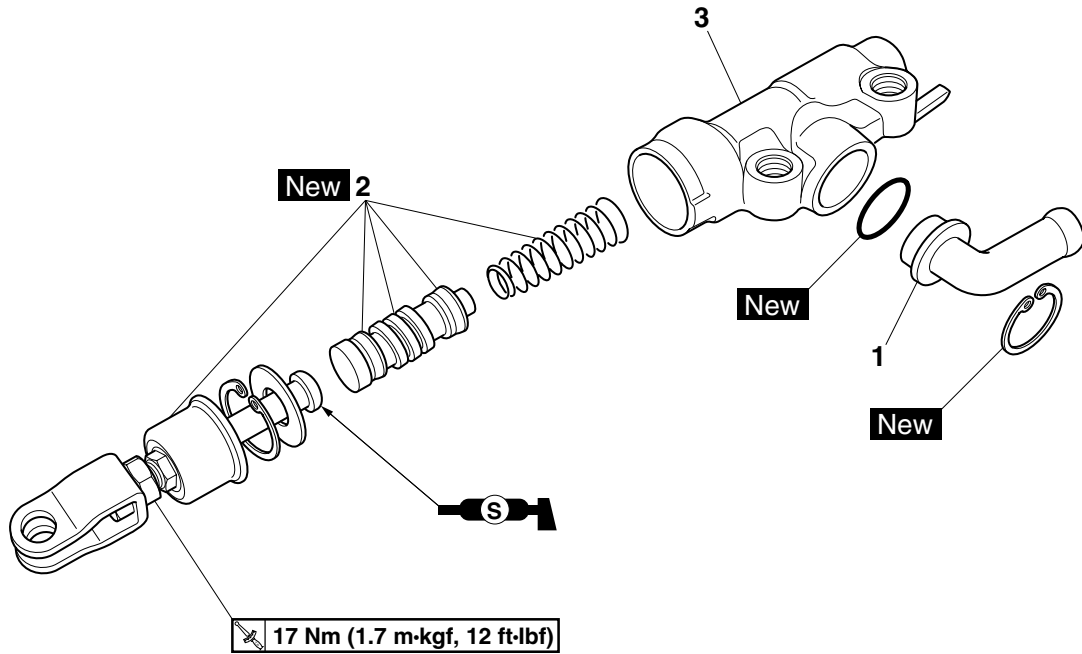

Order	Job/Parts to remove	Q'ty	Remarks
1	Brake hose joint	1	
2	Brake master cylinder kit	1	
3	Brake master cylinder body	1	
			For assembly, reverse the disassembly procedure.



Removing the rear brake caliper

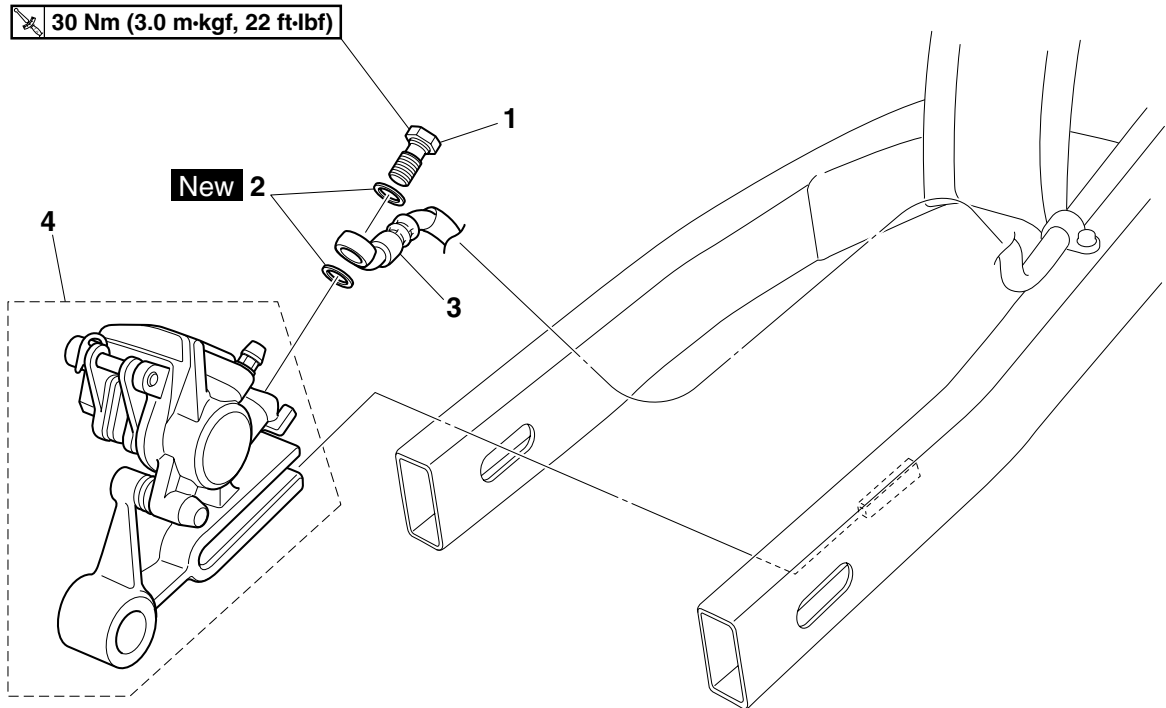

Order	Job/Parts to remove	Q'ty	Remarks
	Brake fluid		Drain. Refer to "BLEEDING THE HYDRAULIC BRAKE SYSTEM" on page 3-19.
	Rear wheel		Refer to "REAR WHEEL" on page 4-13.
1	Rear brake hose union bolt	1	
2	Copper washer	2	
3	Rear brake hose	1	
4	Rear brake caliper	1	
			For installation, reverse the removal procedure.

Disassembling the rear brake caliper

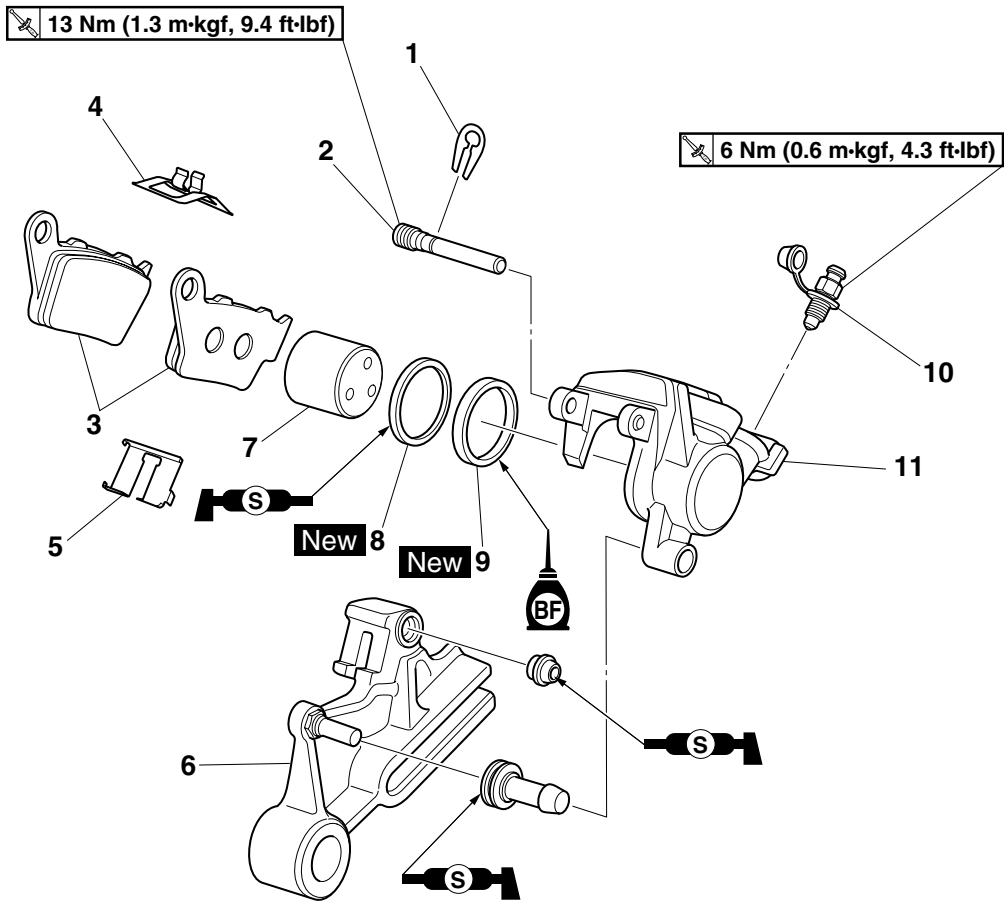

Order	Job/Parts to remove	Q'ty	Remarks
1	Brake pad pin clip	1	
2	Brake pad pin	1	
3	Rear brake pad	2	
4	Brake pad spring	1	
5	Brake pad support	1	
6	Rear brake caliper bracket	1	
7	Brake caliper piston	1	
8	Brake caliper piston dust seal	1	
9	Brake caliper piston seal	1	
10	Bleed screw	1	
11	Brake caliper body	1	
			For assembly, reverse the disassembly procedure.

EAS22560

## INTRODUCTION

EWA14100

### **WARNING**

Disc brake components rarely require disassembly. Therefore, always follow these preventive measures:

- Never disassemble brake components unless absolutely necessary.
- If any connection on the hydraulic brake system is disconnected, the entire brake system must be disassembled, drained, cleaned, properly filled, and bled after reassembly.
- Never use solvents on internal brake components.
- Use only clean or new brake fluid for cleaning brake components.
- Brake fluid may damage painted surfaces and plastic parts. Therefore, always clean up any spilt brake fluid immediately.
- Avoid brake fluid coming into contact with the eyes as it can cause serious injury.
- **FIRST AID FOR BRAKE FLUID ENTERING THE EYES:**
- Flush with water for 15 minutes and get immediate medical attention.

EAS22570

## CHECKING THE REAR BRAKE DISC

1. Remove:
  - Rear wheel  
Refer to "REAR WHEEL" on page 4-13.
2. Check:
  - Brake disc  
Damage/galling → Replace.
3. Measure:
  - Brake disc deflection  
Out of specification → Correct the brake disc deflection or replace the brake disc.  
Refer to "CHECKING THE FRONT BRAKE DISC" on page 4-23.

	<b>Brake disc deflection limit</b> 0.15 mm (0.0059 in)
---	---

4. Measure:
  - Brake disc thickness  
Measure the brake disc thickness at a few different locations.  
Out of specification → Replace.  
Refer to "CHECKING THE FRONT BRAKE DISC" on page 4-23.

	<b>Brake disc thickness limit</b> 4.0 mm (0.16 in)
---	---

5. Adjust:
  - Brake disc deflection  
Refer to "CHECKING THE FRONT BRAKE DISC" on page 4-23.

	<b>Brake disc bolt</b> 12 Nm (1.2 m·kgf, 8.7 ft·lbf) LOCTITE®
---	---

6. Install:
  - Rear wheel  
Refer to "REAR WHEEL" on page 4-13.

EAS22580

## REPLACING THE REAR BRAKE PADS

### TIP

When replacing the brake pads, it is not necessary to disconnect the brake hose or disassemble the brake caliper.

1. Measure:
  - Brake pad wear limit "a"  
Out of specification → Replace the brake pads as a set.

	<b>Brake pad lining thickness (inner)</b> 6.0 mm (0.24 in) <b>Limit</b> 1.0 mm (0.04 in) <b>Brake pad lining thickness (outer)</b> 6.0 mm (0.24 in) <b>Limit</b> 1.0 mm (0.04 in)
---	--

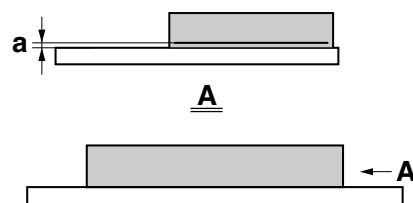

2. Install:
  - Brake pads
  - Brake pad spring
  - Brake pad support



- b. Remove the brake caliper piston dust seal and brake caliper piston seal.



EAS22640

### CHECKING THE REAR BRAKE CALIPER

Recommended brake component replacement schedule	
Brake pads	If necessary
Piston seal	Every two years
Piston dust seal	Every two years
Brake hoses	Every four years
Brake fluid	Every two years and whenever the brake is disassembled

- Check:
  - Brake caliper piston "1"  
Rust/scratches/wear → Replace the brake caliper piston.
  - Brake caliper cylinder "2"  
Scratches/wear → Replace the brake caliper assembly.
  - Brake caliper body "3"  
Cracks/damage → Replace the brake caliper assembly.
  - Brake fluid delivery passages (brake caliper body)  
Obstruction → Blow out with compressed air.

EWA22B1007

### **WARNING**

Whenever a brake caliper is disassembled, replace the brake caliper piston dust seal and brake caliper piston seal.

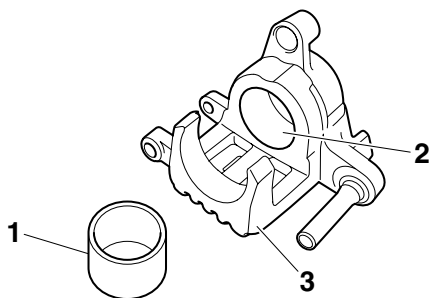

- Check:
  - Rear brake caliper bracket  
Cracks/damage → Replace.

EAS22650

### ASSEMBLING THE REAR BRAKE CALIPER

EWA22B1008

### **WARNING**

- Before installation, all internal brake components should be cleaned and lubricated with clean or new brake fluid.
- Never use solvents on internal brake components as they will cause the brake caliper piston dust seal and brake caliper piston seal to swell and distort.
- Whenever a brake caliper is disassembled, replace the brake caliper piston dust seal and brake caliper piston seal.

	<b>Recommended fluid DOT 4</b>
---	------------------------------------

EAS22670

### INSTALLING THE REAR BRAKE CALIPER

- Install:
  - Rear brake caliper "1" (temporarily)
  - Copper washers **New**
  - Rear brake hose "2"
  - Brake hose union bolt "3"

	<b>Brake hose union bolt 30 Nm (3.0 m·kgf, 22 ft·lbf)</b>
---	---

EWA13530

### **WARNING**

Proper brake hose routing is essential to insure safe vehicle operation. Refer to "CABLE ROUTING" on page 2-35.

ECA14170

### **NOTICE**

When installing the brake hose onto the brake caliper "1", make sure the brake pipe "a" touches the projection "b" on the brake caliper.

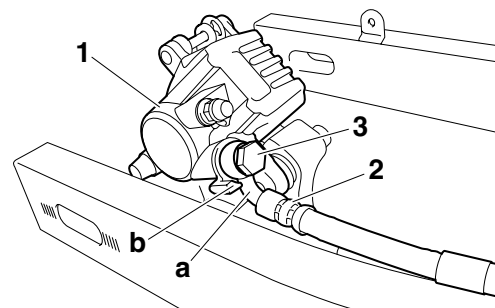

- Remove:
  - Brake caliper

## 3. Install:

- Brake pads
- Brake pad spring
- Brake pad support
- Brake pad pin
- Brake pad pin clip
- Brake caliper

Refer to “REPLACING THE REAR BRAKE PADS” on page 4-36.

## 4. Fill:

- Brake fluid reservoir  
(with the specified amount of the recommended brake fluid)



EWA13090

**WARNING**

- Use only the designated brake fluid. Other brake fluids may cause the rubber seals to deteriorate, causing leakage and poor brake performance.
- Refill with the same type of brake fluid that is already in the system. Mixing brake fluids may result in a harmful chemical reaction, leading to poor brake performance.
- When refilling, be careful that water does not enter the brake fluid reservoir. Water will significantly lower the boiling point of the brake fluid and could cause vapor lock.

ECA13540

**NOTICE**

Brake fluid may damage painted surfaces and plastic parts. Therefore, always clean up any spilt brake fluid immediately.

## 5. Bleed:

- Brake system  
Refer to “BLEEDING THE HYDRAULIC BRAKE SYSTEM” on page 3-19.

## 6. Check:

- Brake fluid level  
Below the minimum level mark “a” → Add the recommended brake fluid to the proper level. Refer to “CHECKING THE BRAKE FLUID LEVEL” on page 3-17.

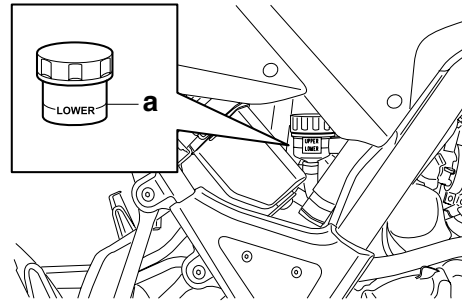

## 7. Check:

- Brake pedal operation  
Soft or spongy feeling → Bleed the brake system.  
Refer to “BLEEDING THE HYDRAULIC BRAKE SYSTEM” on page 3-19.

EAS22700

**REMOVING THE REAR BRAKE MASTER CYLINDER**

## 1. Remove:

- Rear brake light switch
- Copper washers
- Rear brake hose

**TIP**

To collect any remaining brake fluid, place a container under the master cylinder and the end of the brake hose.

EAS22720

**CHECKING THE REAR BRAKE MASTER CYLINDER**

## 1. Check:

- Brake master cylinder  
Damage/scratches/wear → Replace.
- Brake fluid delivery passages (brake master cylinder body)  
Obstruction → Blow out with compressed air.

## 2. Check:

- Brake master cylinder kit  
Damage/scratches/wear → Replace.

## 3. Check:

- Brake fluid reservoir  
Cracks/damage → Replace.
- Brake fluid reservoir diaphragm  
Cracks/damage → Replace.

## 4. Check:

- Brake hoses  
Cracks/damage/wear → Replace.

EAS22730

## ASSEMBLING THE REAR BRAKE MASTER CYLINDER

EWA13520

### **WARNING**

- Before installation, all internal brake components should be cleaned and lubricated with clean or new brake fluid.
- Never use solvents on internal brake components.



**Recommended fluid**  
DOT 4

EAS22740

## INSTALLING THE REAR BRAKE MASTER CYLINDER

1. Install:

- Copper washers **New**
- Rear brake hose “1”
- Rear brake light switch “2”



**Rear brake light switch**  
24 Nm (2.4 m·kgf, 17 ft·lbf)

EWA13530

### **WARNING**

Proper brake hose routing is essential to insure safe vehicle operation. Refer to “CABLE ROUTING” on page 2-35.

ECA14160

### **NOTICE**

When installing the brake hose onto the brake master cylinder, make sure the brake pipe touches the projection “a” as shown.

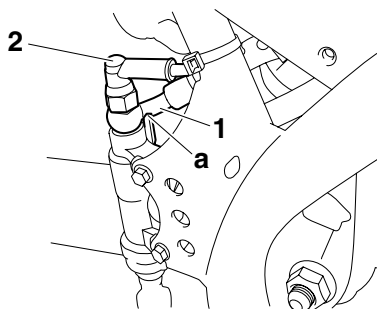

2. Fill:

- Brake fluid reservoir (with the specified amount of the recommended brake fluid)



**Recommended fluid**  
DOT 4

EWA13090

### **WARNING**

- Use only the designated brake fluid. Other brake fluids may cause the rubber seals to deteriorate, causing leakage and poor brake performance.
- Refill with the same type of brake fluid that is already in the system. Mixing brake fluids may result in a harmful chemical reaction, leading to poor brake performance.
- When refilling, be careful that water does not enter the brake fluid reservoir. Water will significantly lower the boiling point of the brake fluid and could cause vapor lock.

ECA13540

### **NOTICE**

Brake fluid may damage painted surfaces and plastic parts. Therefore, always clean up any spilt brake fluid immediately.

3. Bleed:

- Brake system  
Refer to “BLEEDING THE HYDRAULIC BRAKE SYSTEM” on page 3-19.

4. Check:

- Brake fluid level  
Below the minimum level mark “a” → Add the recommended brake fluid to the proper level. Refer to “CHECKING THE BRAKE FLUID LEVEL” on page 3-17.

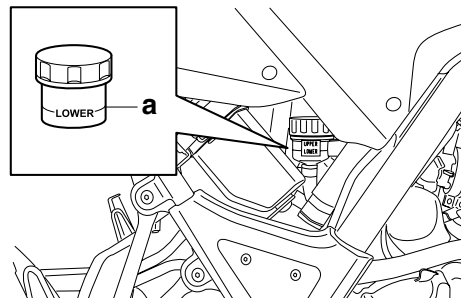

5. Check:

- Brake pedal operation  
Soft or spongy feeling → Bleed the brake system.  
Refer to “BLEEDING THE HYDRAULIC BRAKE SYSTEM” on page 3-19.

6. Adjust:

- Brake pedal position  
Refer to “ADJUSTING THE REAR DISC BRAKE” on page 3-17.



**Brake pedal position**  
12.0 mm (0.47 in)

EAS22840

## HANDLEBAR

### Removing the handlebar

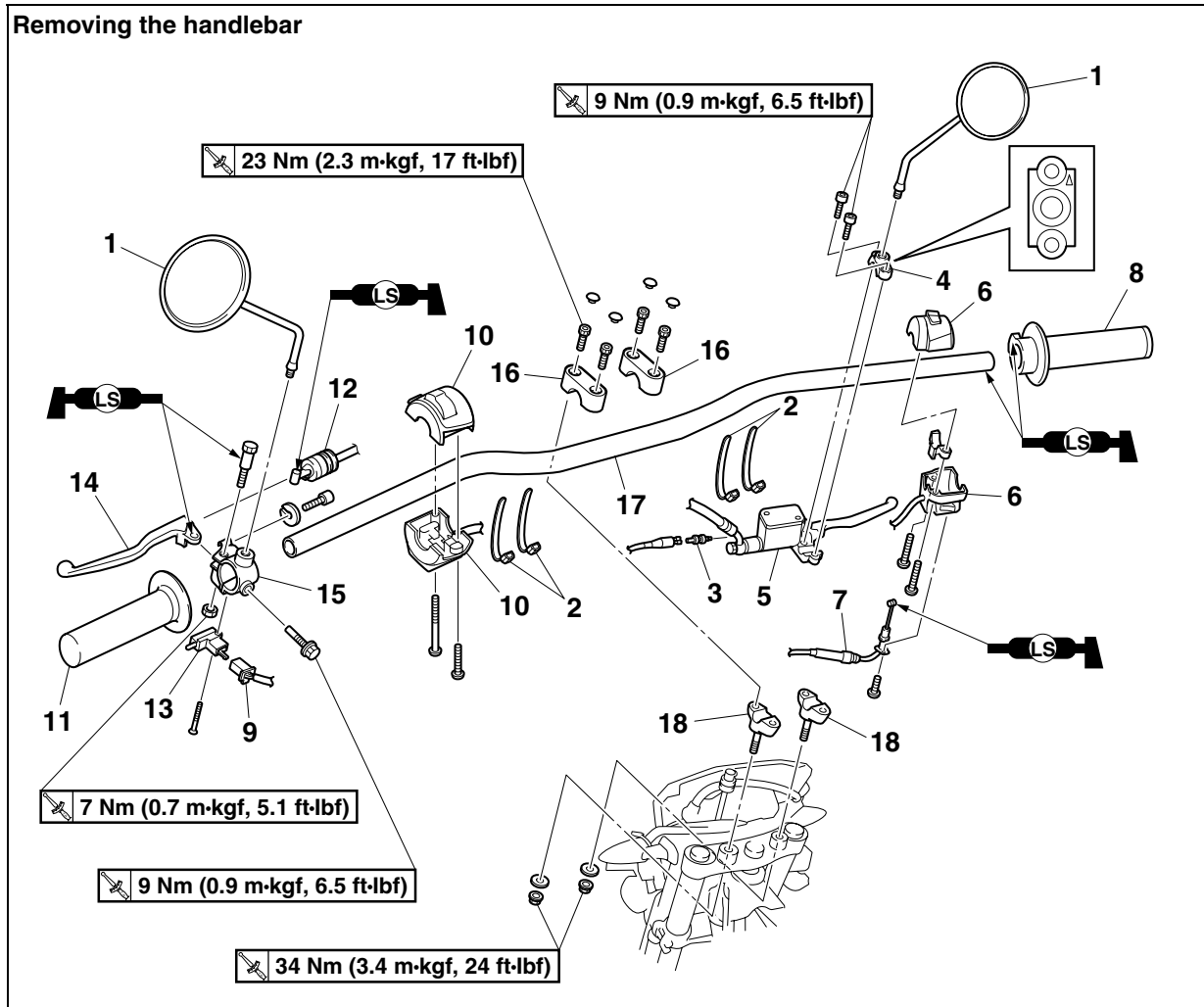

Order	Job/Parts to remove	Q'ty	Remarks
1	Rearview mirror	2	
2	Plastic band	4	
3	Front brake light switch	1	
4	Front brake master cylinder holder	1	
5	Front brake master cylinder assembly	1	
6	Right handlebar switch	1	
7	Throttle cable	1	Disconnect.
8	Throttle grip	1	
9	Clutch switch coupler	1	Disconnect.
10	Left handlebar switch	1	
11	Handlebar grip	1	
12	Clutch cable	1	Disconnect.
13	Clutch switch	1	
14	Clutch lever	1	
15	Clutch lever holder	1	
16	Upper handlebar holder	2	



Removing the handlebar

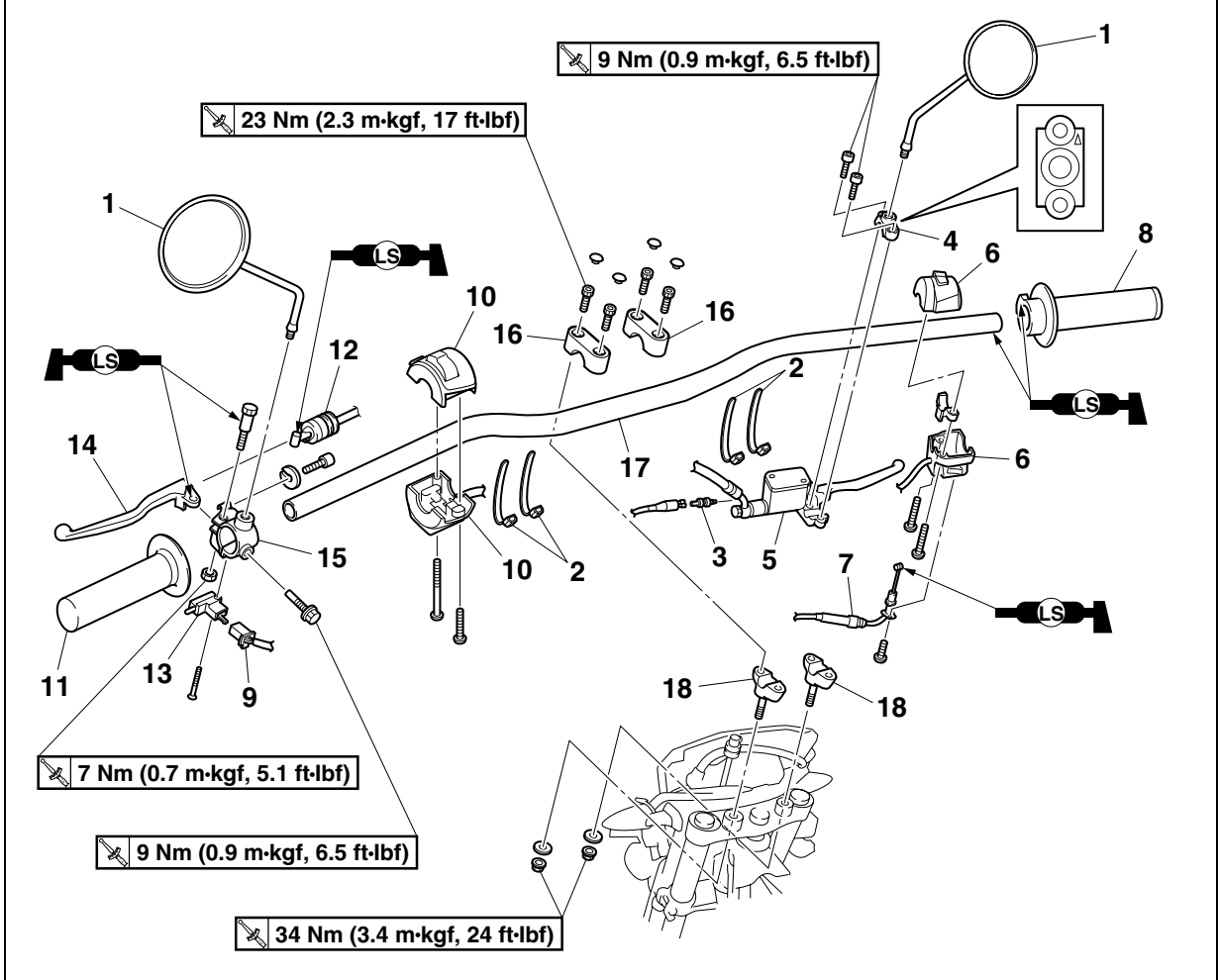

Order	Job/Parts to remove	Q'ty	Remarks
17	Handlebar	1	
18	Lower handlebar holder	2	
			For installation, reverse the removal procedure.

EAS22860

## REMOVING THE HANDLEBAR

- Stand the vehicle on a level surface.

EWA13120

### **WARNING**

**Securely support the vehicle so that there is no danger of it falling over.**

- Remove:
  - Front brake light switch

### TIP

The front brake light switch is a screw-type switch. Unscrew the switch to remove it from the brake master cylinder.

- Remove:
  - Handlebar grip "1"

### TIP

Blow compressed air between the handlebar and the handlebar grip, and gradually push the grip off the handlebar.

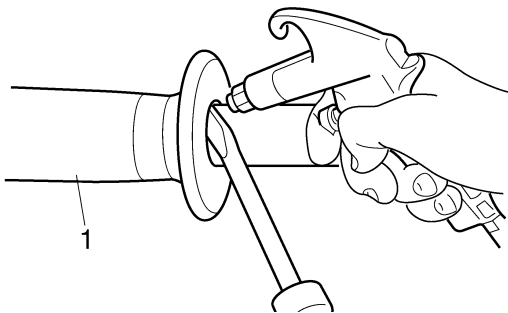

EAS22880

## CHECKING THE HANDLEBAR

- Check:
  - Handlebar
    - Bends/cracks/damage → Replace.

EWA13690

### **WARNING**

**Do not attempt to straighten a bent handlebar as this may dangerously weaken it.**

EAS22911

## INSTALLING THE HANDLEBAR

- Stand the vehicle on a level surface.

EWA13120

### **WARNING**

**Securely support the vehicle so that there is no danger of it falling over.**

- Install:
  - Lower handlebar holders
  - Washers
  - Lower handlebar holder nuts

### TIP

Temporarily tighten the nuts.

- Install:
  - Handlebar "1"
  - Upper handlebar holders "2"



**Upper handlebar holder bolt**  
23 Nm (2.3 m·kgf, 17 ft·lbf)

ECA22B1027

### **NOTICE**

- First, tighten the front bolt on each handlebar holder, then the rear bolt.**
- Turn the handlebar all the way to the left and right. If there is any contact with the fuel tank, adjust the handlebar position.**

### TIP

- The upper handlebar holders should be installed with the arrow marks "a" facing forward.
- Align the match mark "b" on the handlebar with the upper surface of the lower handlebar holder.

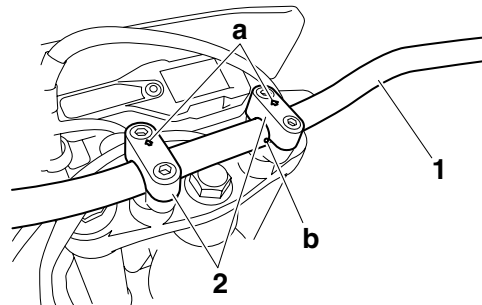

- Tighten:
  - Lower handlebar holder nuts



**Lower handlebar holder nut**  
34 Nm (3.4 m·kgf, 24 ft·lbf)

- Install:
  - Clutch lever holder "1"



**Clutch lever holder bolt**  
9 Nm (0.9 m·kgf, 6.5 ft·lbf)

### TIP

Align the slit in the clutch lever holder with the punch mark "a" on the handlebar.

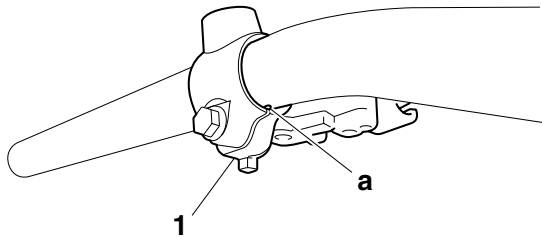

6. Install:
- Clutch lever
  - Clutch switch "1"

**TIP**

Align the projection "a" on the clutch switch with the slit "b" in the clutch lever holder.

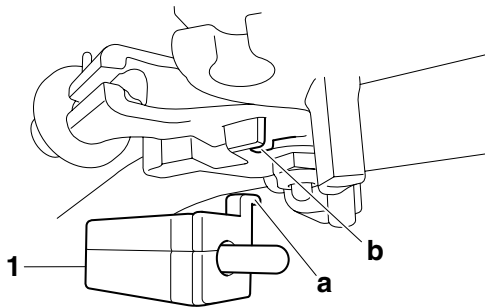

7. Connect:
- Clutch cable

**TIP**

Lubricate the end of the clutch cable with a thin coat of lithium-soap-based grease.

8. Install:
- Handlebar grip

- a. Apply a thin coat of rubber adhesive onto the left end of the handlebar.
- b. Slide the handlebar grip over the left end of the handlebar and install the grip so that the arrow mark "L" on the grip faces up and is within the angle shown in the illustration.
- c. Wipe off any excess rubber adhesive with a clean rag.

EWA13700

**WARNING**

Do not touch the handlebar grip until the rubber adhesive has fully dried.

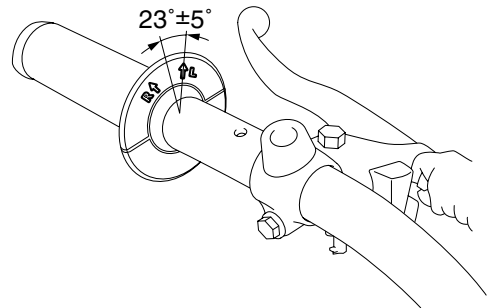

9. Install:
- Left handlebar switch "1"

**TIP**

Align the projection "a" on the left handlebar switch with the hole "b" in the handlebar.

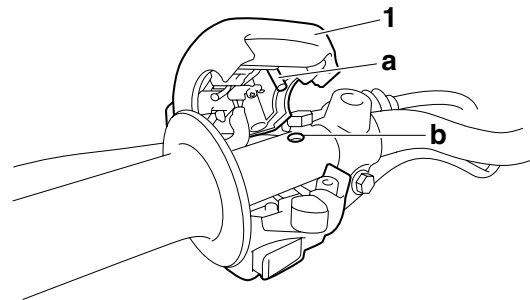

10. Install:
- Throttle grip "1"
  - Throttle cable "2"
  - Right handlebar switch "3"

**TIP**

- Be sure to position the washer between the throttle grip and the right handlebar switch.
- Lubricate the end of the throttle cable and the inside of the throttle grip with a thin coat of lithium-soap-based grease, and then install the throttle grip onto the handlebar.
- Route the throttle cable through the slot in the throttle grip, and then install the cable.
- Align the projection "a" on the right handlebar switch with the hole "b" on the handlebar.

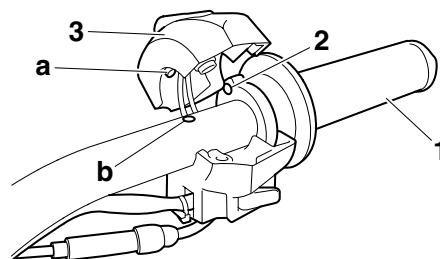

## 11.Install:

- Front brake master cylinder "1"
- Front brake master cylinder holder "2"

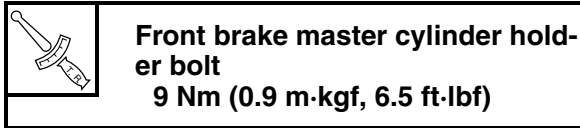
**TIP**

- Install the brake master cylinder holder with the arrow mark "a" pointing forward.
- Align the mating surfaces of the brake master cylinder holder with the punch mark "b" on the handlebar.
- First, tighten the front bolt, then the rear bolt.

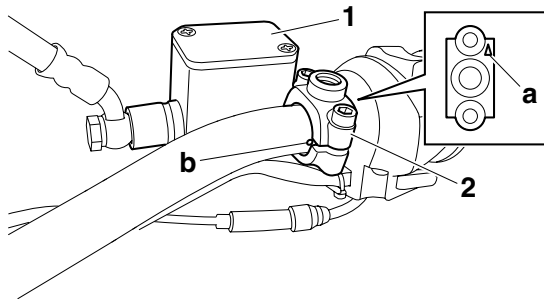

## 12.Adjust:

- Clutch cable free play  
Refer to "ADJUSTING THE CLUTCH CABLE FREE PLAY" on page 3-12.



## 13.Adjust:

- Throttle cable free play  
Refer to "ADJUSTING THE THROTTLE CABLE FREE PLAY" on page 3-6.

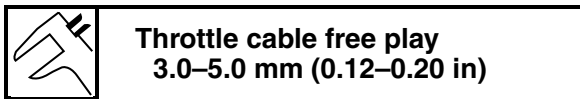

EAS22950

**FRONT FORK**

**Removing the front fork legs (WR125R)**

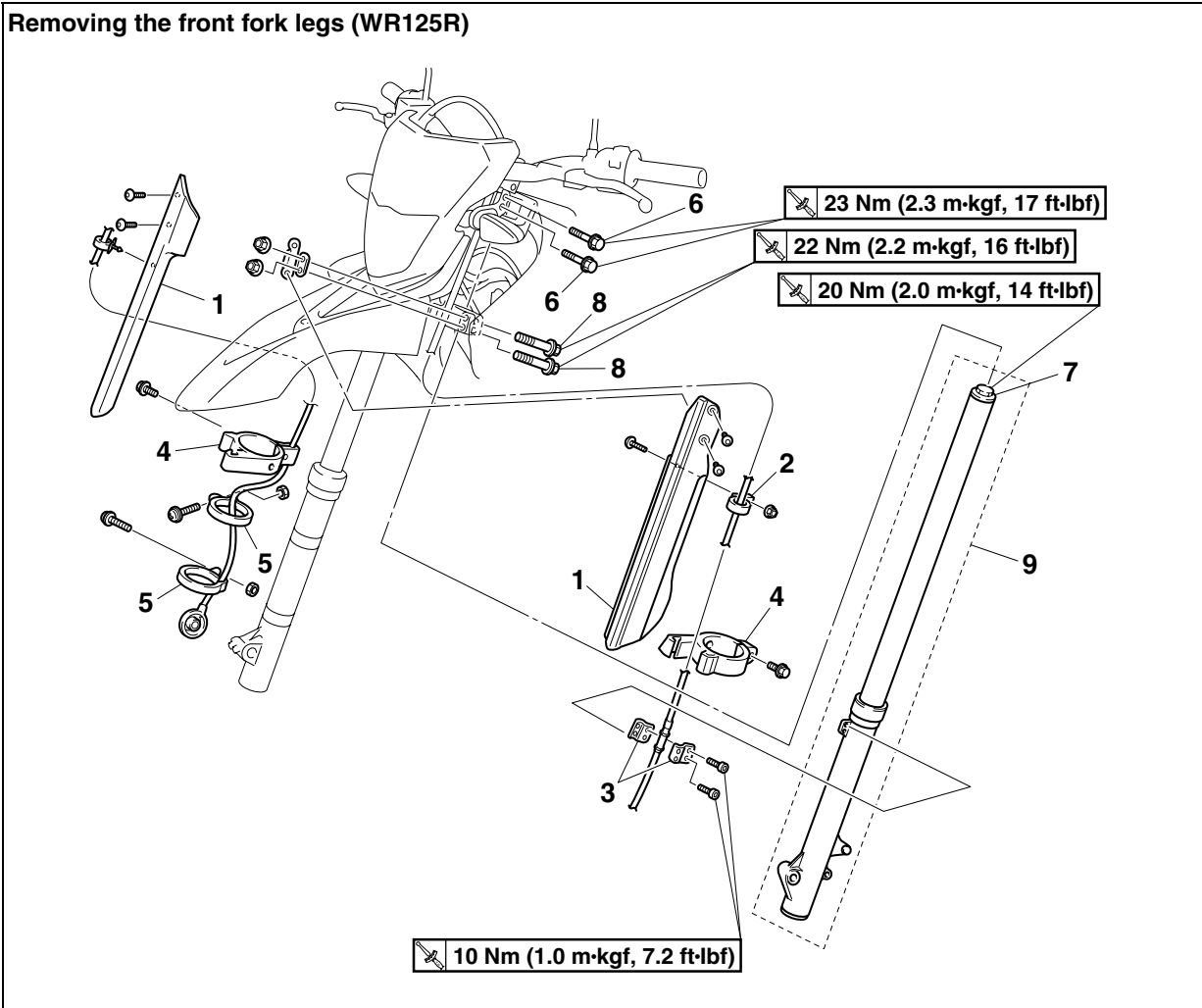

Order	Job/Parts to remove	Q'ty	Remarks
			The following procedure applies to both of the front fork legs.
	Front wheel		Refer to "FRONT WHEEL" on page 4-6.
	Front brake caliper		Refer to "FRONT BRAKE" on page 4-19.
1	Front fork protector	2	
2	Brake hose guide	1	
3	Brake hose holder	2	
4	Front fork protector guide	2	
5	Speed sensor lead holder	2	
6	Upper bracket pinch bolt	2	Loosen.
7	Front fork cap bolt	1	Loosen.
8	Lower bracket pinch bolt	2	Loosen.
9	Front fork leg	1	
			For installation, reverse the removal procedure.

Removing the front fork legs (WR125X)

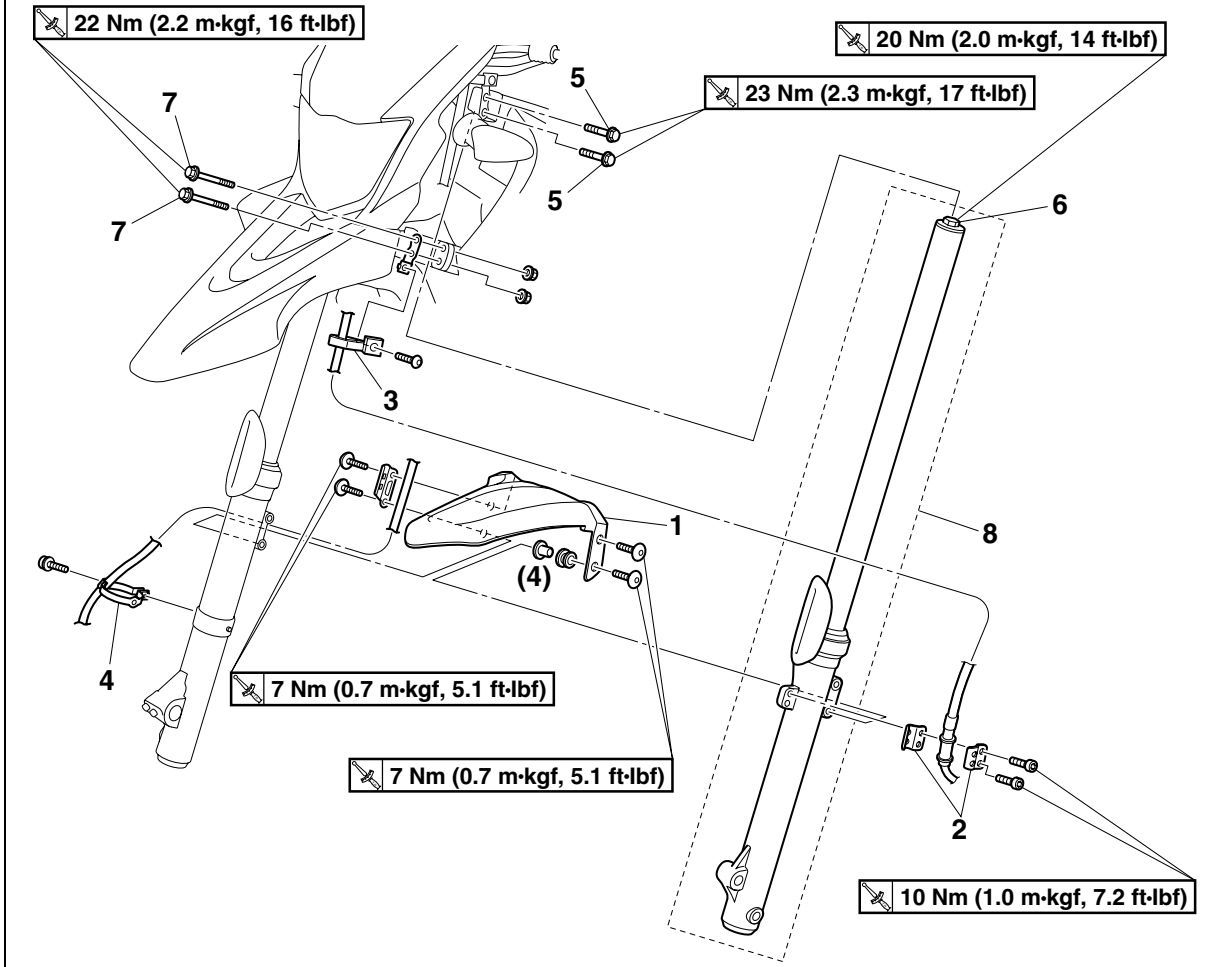

Order	Job/Parts to remove	Q'ty	Remarks
			The following procedure applies to both of the front fork legs.
	Front wheel		Refer to "FRONT WHEEL" on page 4-6.
1	Front mudguard	1	
2	Brake hose holder	2	
3	Brake hose guide	1	
4	Speed sensor lead holder	1	
5	Upper bracket pinch bolt	2	Loosen.
6	Front fork cap bolt	1	Loosen.
7	Lower bracket pinch bolt	2	Loosen.
8	Front fork leg	1	
			For installation, reverse the removal procedure.

Disassembling the front fork legs

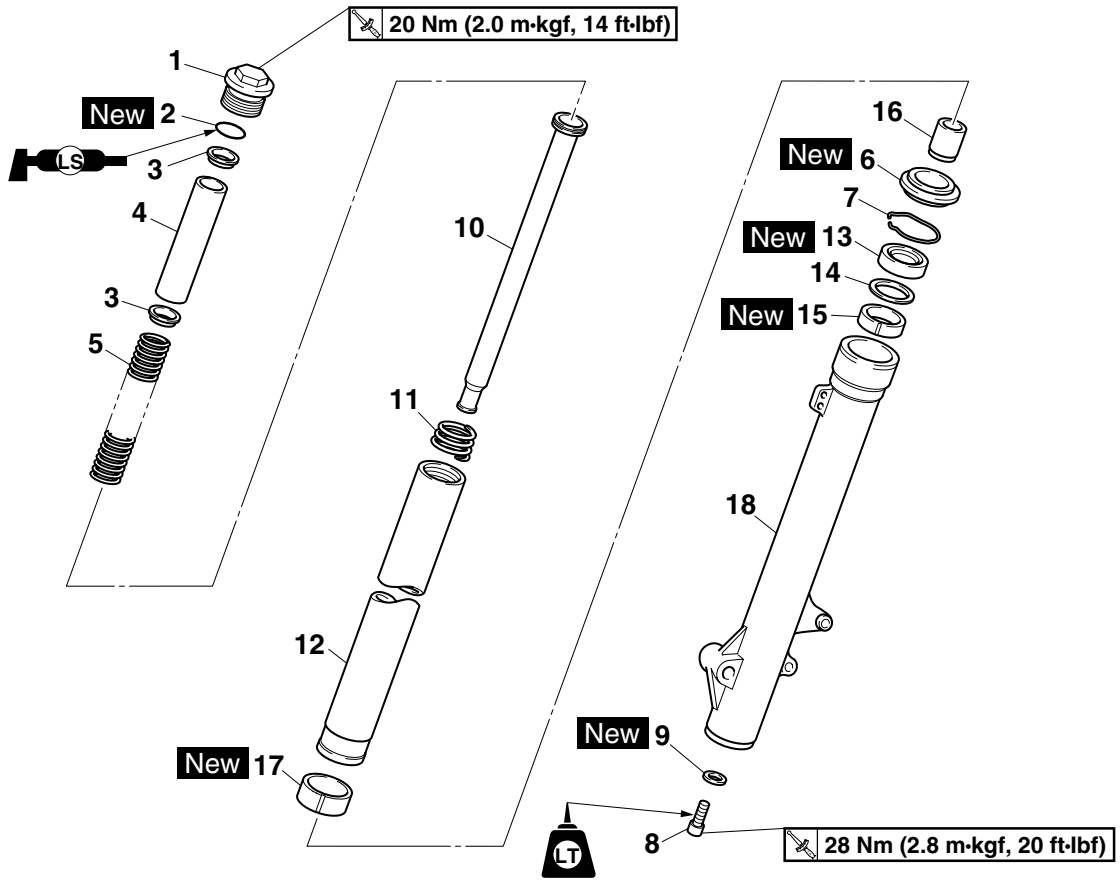

Order	Job/Parts to remove	Q'ty	Remarks
			The following procedure applies to both of the front fork legs.
1	Cap bolt	1	
2	O-ring	1	
3	Spring seat	2	
4	Spacer	1	
5	Fork spring	1	
6	Dust seal	1	
7	Oil seal clip	1	
8	Damper rod bolt	1	
9	Copper washer	1	
10	Damper rod	1	
11	Rebound spring	1	
12	Inner tube	1	
13	Oil seal	1	
14	Washer	1	
15	Outer tube bushing	1	
16	Oil flow stopper	1	

Disassembling the front fork legs

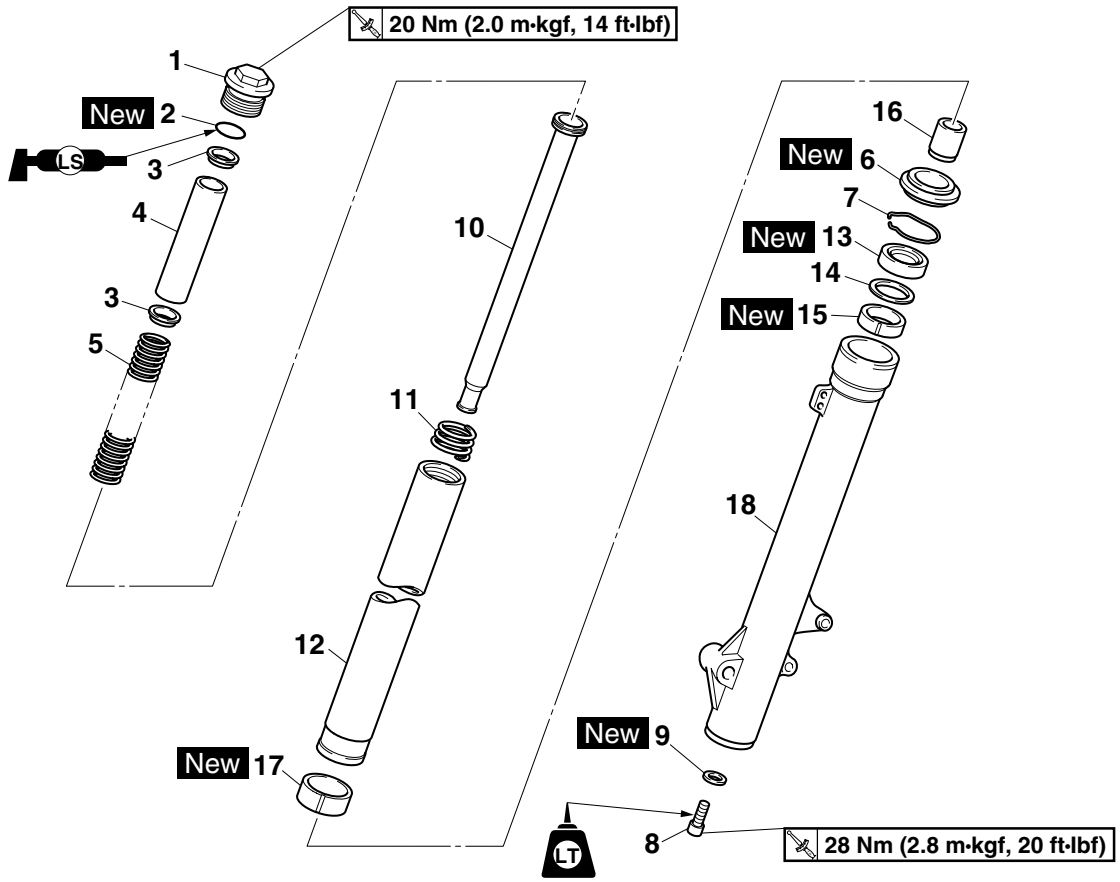

Order	Job/Parts to remove	Q'ty	Remarks
17	Inner tube bushing	1	
18	Outer tube	1	
			For assembly, reverse the disassembly procedure.



EAS22960

## REMOVING THE FRONT FORK LEGS

The following procedure applies to both of the front fork legs.

1. Stand the vehicle on a level surface.

EWA13120

### **WARNING**

**Securely support the vehicle so that there is no danger of it falling over.**

### TIP

Place the vehicle on a suitable stand so that the front wheel is elevated.

2. Loosen:

- Upper bracket pinch bolts "1"
- Cap bolt "2"
- Lower bracket pinch bolts "3"

EWA13640

### **WARNING**

**Before loosening the upper and lower bracket pinch bolts, support the front fork leg.**

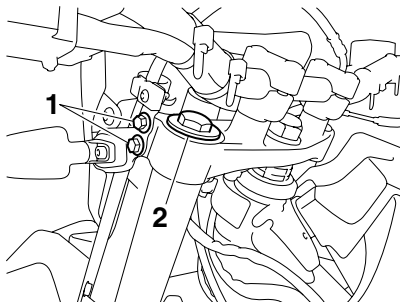

**A**

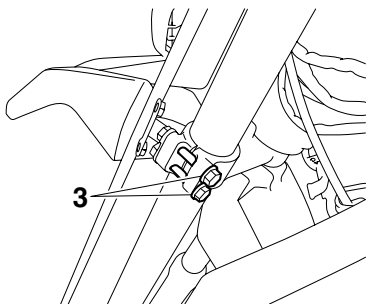

**B**

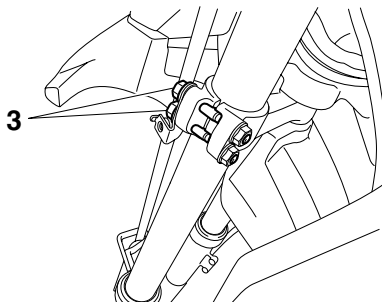

- A. WR125R
- B. WR125X

3. Remove:

- Front fork leg

EAS22980

## DISASSEMBLING THE FRONT FORK LEGS

The following procedure applies to both of the front fork legs.

1. Drain:

- Fork oil

### TIP

Stroke the inner tube several times while draining the fork oil.

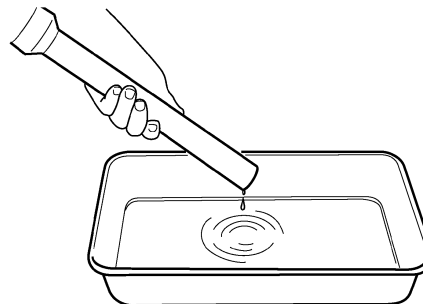

2. Remove:

- Dust seal "1"
- Oil seal clip "2"  
(with a flat-head screwdriver)

ECA14180

### **NOTICE**

**Do not scratch the inner tube.**

### TIP

- Do not remove the fork leg protector from the outer tube (WR125X).
- If the front fork leg protector must be removed, always install a new one (WR125X).

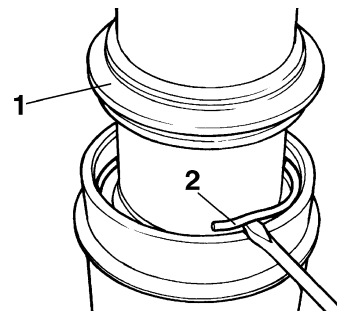

3. Remove:

- Damper rod bolt "1"
- Copper washer

### TIP

While holding the damper rod with the damper rod holder "2" and T-handle "3", loosen the damper rod bolt.



**TIP**

- When assembling the front fork leg, be sure to replace the following parts:
  - Inner tube bushing
  - Outer tube bushing
  - Oil seal
  - Dust seal
- Before assembling the front fork leg, make sure all of the components are clean.

**1. Install:**

- Inner tube bushing "1" **New**
- Damper rod "2"
- Rebound spring "3"
- Oil flow stopper "4"

ECA22B1030

**NOTICE**

**Allow the damper rod assembly to slide slowly down the inner tube "5" until it protrudes from the bottom of the inner tube. Be careful not to damage the inner tube.**

**TIP**

Install the rebound spring "3" with its smaller diameter end "a" facing up.

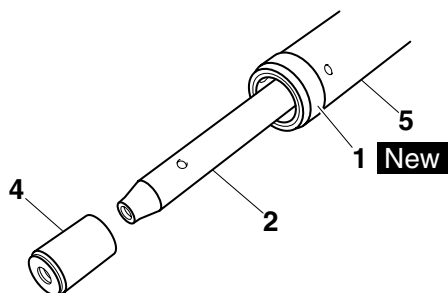
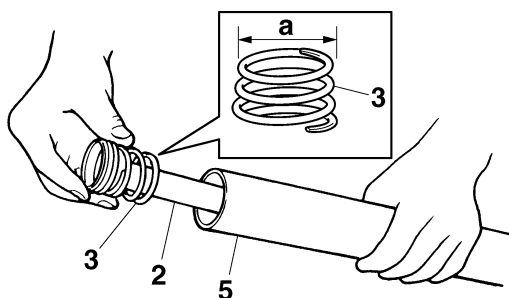

**2. Lubricate:**

- Inner tube outer surface

	<b>Recommended oil</b> Fork oil 10W or equivalent
---	--

**3. Tighten:**

- Damper rod bolt "1"



**Damper rod bolt**  
28 Nm (2.8 m·kgf, 20 ft·lbf)  
LOCTITE®

**TIP**

While holding the damper rod with the damper rod holder "2" and T-handle "3", tighten the damper rod bolt.



**Damper rod holder**  
90890-01460  
**T-handle**  
90890-01326  
T-handle 3/8" drive 60 cm long  
YM-01326

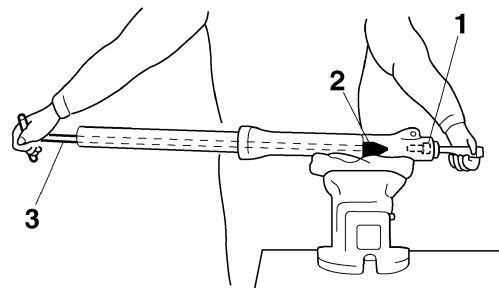

**4. Install:**

- Outer tube bushing "1" **New**
  - Washer "2"
- (with the fork seal driver weight "3" and fork seal driver attachment "4")



**Fork seal driver weight**  
90890-01367  
**Replacement hammer**  
YM-A9409-7  
**Fork seal driver attachment (ø41)**  
90890-01381  
**Replacement 41 mm**  
YM-A5142-2

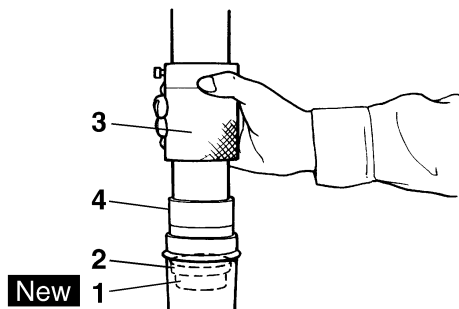

### 5. Install:

- Oil seal “1” **New**  
(with the fork seal driver weight “2” and fork seal driver attachment “3”)

ECA14220

#### NOTICE

**Make sure the numbered side of the oil seal faces up.**

#### TIP

- Before installing the oil seal, lubricate its lips with lithium-soap-based grease.
- Lubricate the outer surface of the inner tube with fork oil.
- Before installing the oil seal, cover the top of the front fork leg with a plastic bag to protect the oil seal during installation.

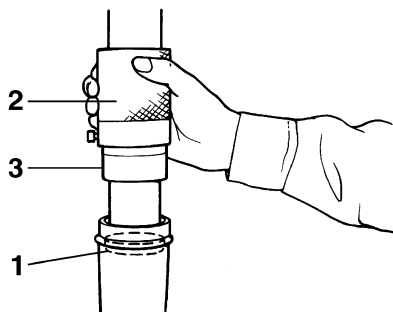
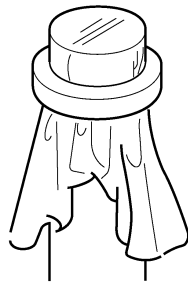

### 6. Install:

- Oil seal clip “1” **New**

#### TIP

Adjust the oil seal clip so that it fits into the outer tube groove.

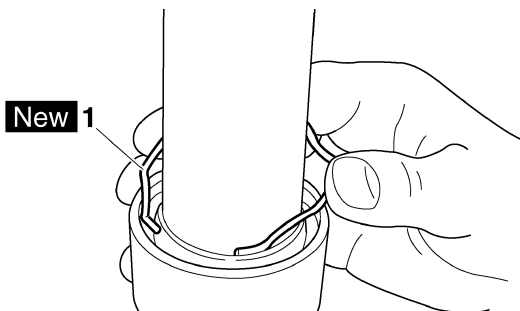

### 7. Install:

- Dust seal “1” **New**  
(with the fork seal driver “2”)



**Fork seal driver weight**  
**90890-01367**  
**Replacement hammer**  
**YM-A9409-7**

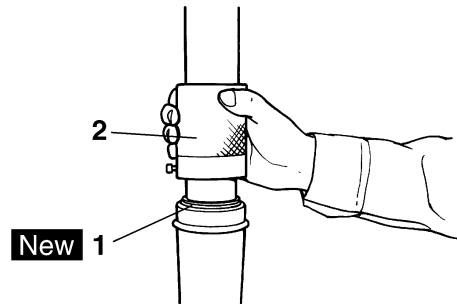

### 8. Fill:

- Front fork leg  
(with the specified amount of the recommended fork oil)



**Quantity**  
**WR125R 560.0 cm<sup>3</sup> (18.93 US oz,**  
**19.75 Imp.oz)**  
**WR125X 610.0 cm<sup>3</sup> (20.62 US oz,**  
**21.51 Imp.oz)**  
**Recommended oil**  
**Fork oil 10W or equivalent**

### 9. Measure:

- Front fork leg oil level “a”  
(from the top of the inner tube, with the outer tube fully compressed and without the fork spring)  
Out of specification → Correct.



**Level**  
**WR125R 165.0 mm (6.50 in)**  
**WR125X 145.0 mm (5.71 in)**

#### TIP

- While filling the front fork leg, keep it upright.
- After filling, slowly pump the front fork leg up and down to distribute the fork oil.

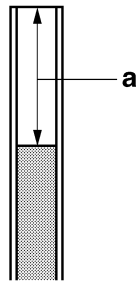

10. Install:

- Spring
- Spring seats
- Spacer
- Cap bolt

(along with the O-ring **New**)

**TIP**

- Before installing the cap bolt, lubricate its O-ring with grease.
- Temporarily tighten the cap bolt.

EAS23050

**INSTALLING THE FRONT FORK LEGS**

The following procedure applies to both of the front fork legs.

1. Install:

- Front fork leg  
Temporarily tighten the upper and lower bracket pinch bolts.

**TIP**

Make sure the inner tube is flush with the top of the upper bracket.

2. Tighten:

- Lower bracket pinch bolts "1"

	<b>Lower bracket pinch bolt</b> 22 Nm (2.2 m·kgf, 16 ft·lbf)
--	---

- Cap bolt "2"

	<b>Cap bolt</b> 20 Nm (2.0 m·kgf, 14 ft·lbf)
--	---

- Upper bracket pinch bolts "3"

	<b>Upper bracket pinch bolt</b> 23 Nm (2.3 m·kgf, 17 ft·lbf)
--	---

EWA22B1018

**WARNING**

Make sure the brake hose is routed properly.

**TIP**

Tighten the lower bracket pinch bolts to specification twice, each time in the order of lower pinch bolt → upper pinch bolt. Do not loosen the bolts after tightening them to specification.

**A**

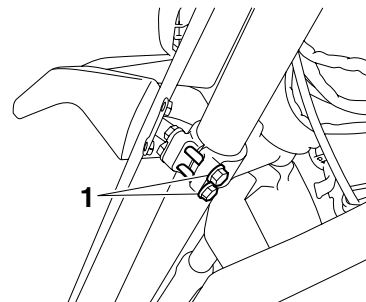

**B**

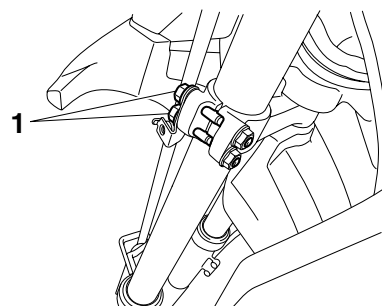

A. WR125R

B. WR125X

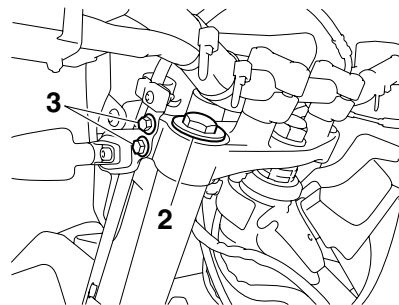

EAS23090

## STEERING HEAD

### Removing the headlight assembly and meter assembly

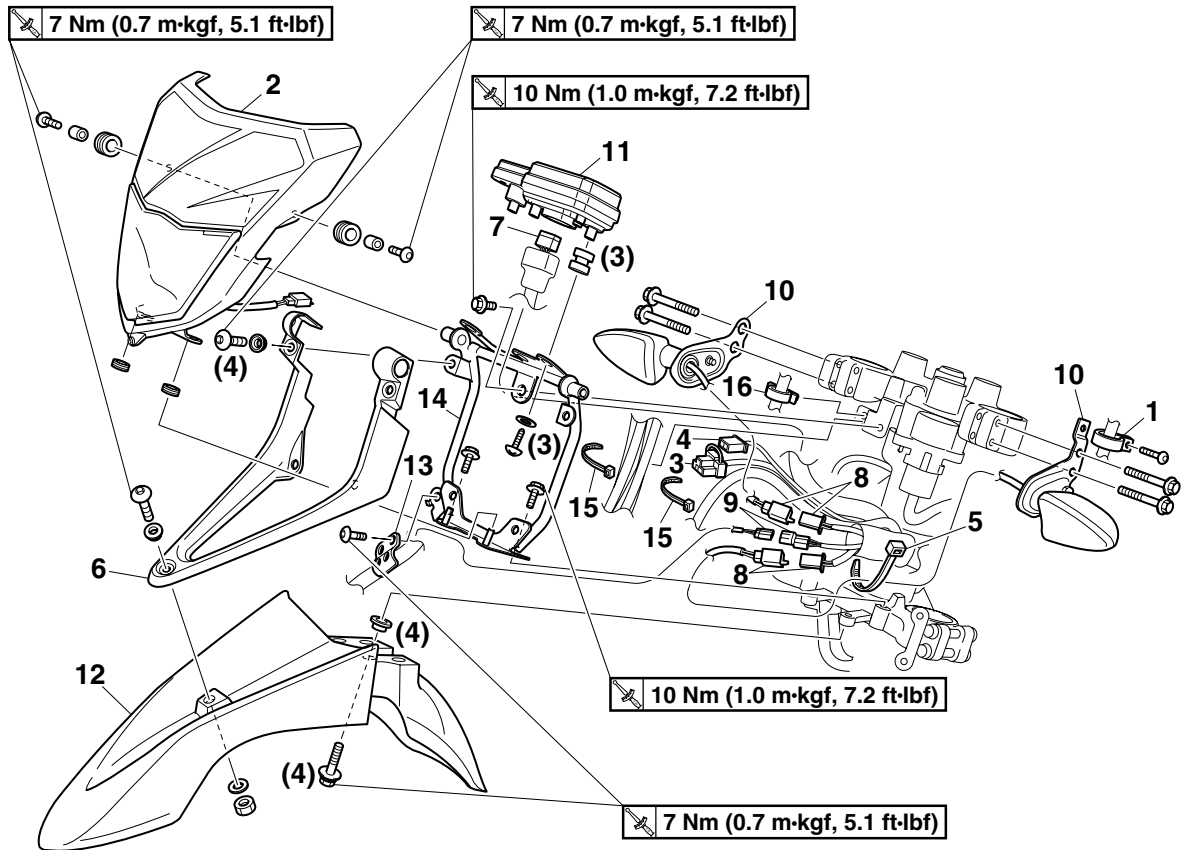

Order	Job/Parts to remove	Q'ty	Remarks
	Handlebar		Refer to "HANDLEBAR" on page 4-41.
	Front fork		Refer to "FRONT FORK" on page 4-46.
	Fuel tank		Refer to "FUEL TANK" on page 7-1.
1	Brake hose guide	1	
2	Headlight assembly	1	
3	Headlight coupler	1	Disconnect.
4	Auxiliary light coupler	1	Disconnect.
5	Plastic locking tie	1	
6	Headlight bracket cover	1	
7	Meter assembly coupler	1	Disconnect.
8	Front turn signal light coupler	2	Disconnect.
9	Speed sensor lead coupler	1	Disconnect.
10	Turn signal light	2	
11	Meter assembly	1	
12	Front fender	1	
13	Speed sensor lead holder	1	

Removing the headlight assembly and meter assembly

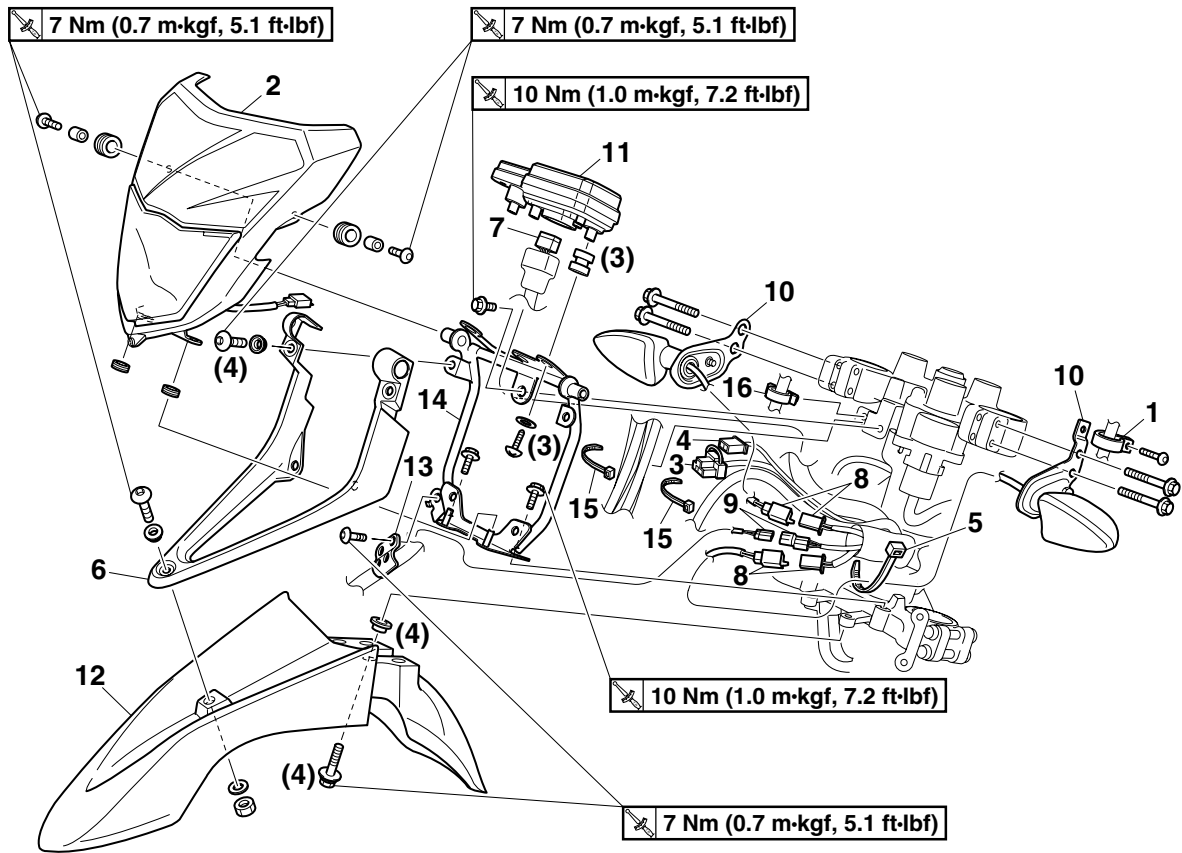

Order	Job/Parts to remove	Q'ty	Remarks
14	Headlight bracket	1	
15	Plastic locking tie	2	
16	Throttle cable holder	1	
			For installation, reverse the removal procedure.

Removing the lower bracket

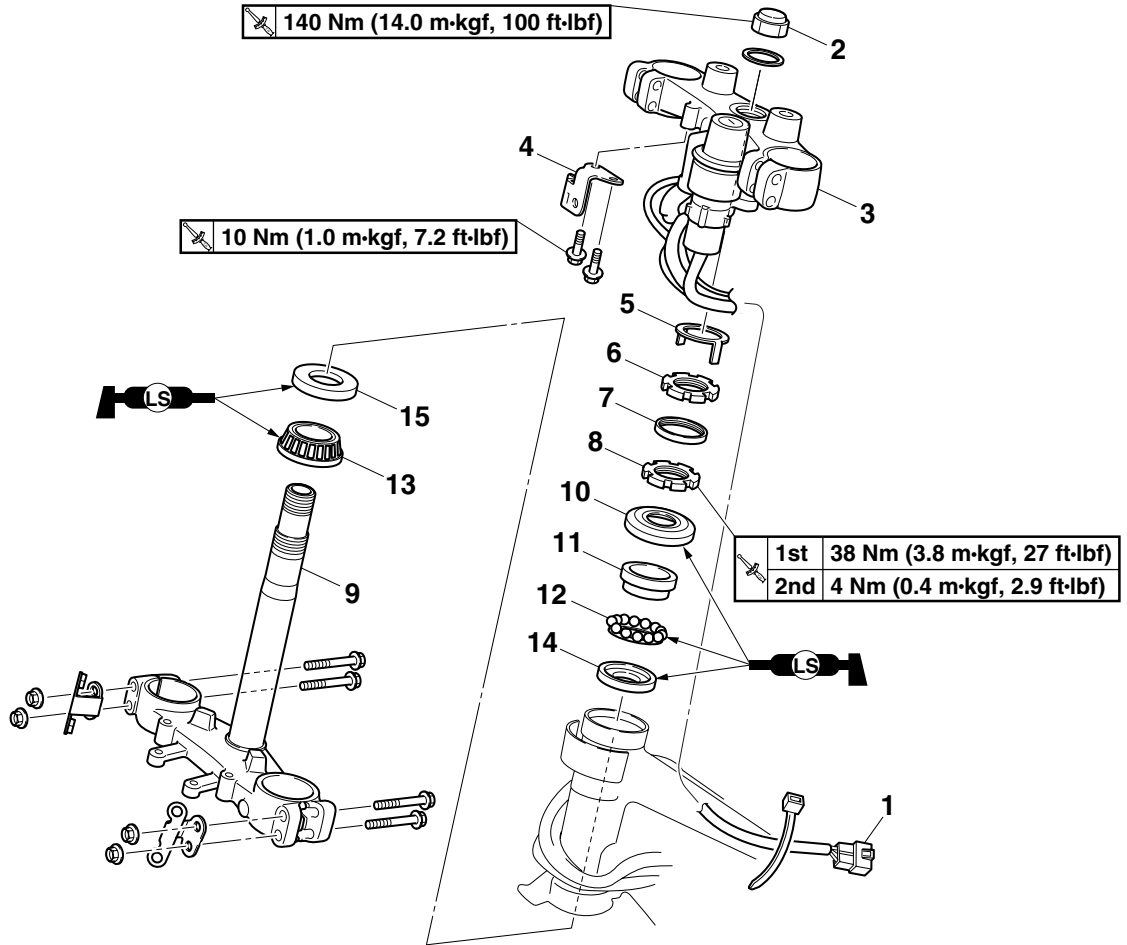

Order	Job/Parts to remove	Q'ty	Remarks
1	Main switch coupler	1	Disconnect.
2	Steering stem nut	1	
3	Upper bracket	1	
4	Upper bracket stay	1	
5	Lock washer	1	
6	Upper ring nut	1	
7	Rubber washer	1	
8	Lower ring nut	1	
9	Lower bracket	1	
10	Bearing cover	1	
11	Upper bearing inner race	1	
12	Upper bearing	1	
13	Lower bearing	1	
14	Upper bearing outer race	1	
15	Lower bearing outer race	1	
			For installation, reverse the removal procedure.



EAS23110

## REMOVING THE LOWER BRACKET

1. Stand the vehicle on a level surface.

EWA13120

### **WARNING**

**Securely support the vehicle so that there is no danger of it falling over.**

2. Remove:

- Upper ring nut
- Rubber washer
- Lower ring nut "1"
- Lower bracket

### TIP

Remove the lower ring nut with the steering nut wrench "2".



**Steering nut wrench**  
90890-01403  
**Exhaust flange nut wrench**  
YU-A9472

EWA13730

### **WARNING**

**Securely support the lower bracket so that there is no danger of it falling.**

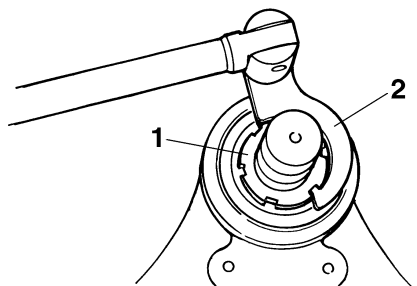

EAS23120

## CHECKING THE STEERING HEAD

1. Wash:

- Bearings
- Bearing races



**Recommended cleaning solvent**  
Kerosene

2. Check:

- Bearings
  - Bearing races
- Damage/pitting → Replace.

3. Replace:

- Bearings
- Bearing races



- a. Remove the bearing races from the steering head pipe with a long rod "1" and hammer.
- b. Remove the bearing race from the lower bracket with a floor chisel "2" and hammer.
- c. Install new bearing races.

ECA14270

### **NOTICE**

**If the bearing race is not installed properly, the steering head pipe could be damaged.**

### TIP

Always replace the bearings and bearing races as a set.

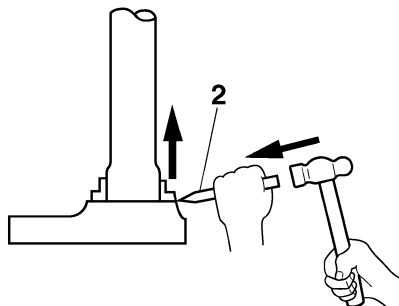
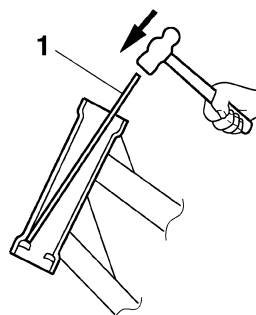

4. Check:

- Upper bracket
  - Lower bracket
- (along with the steering stem)  
Bends/cracks/damage → Replace.

EAS23140

## INSTALLING THE STEERING HEAD

1. Lubricate:

- Upper bearing
- Lower bearing
- Bearing races



**Recommended lubricant**  
Lithium-soap-based grease

2. Install:

- Lower ring nut "1"
- Rubber washer "2"

- Upper ring nut "3"
- Lock washer "4"

Refer to "CHECKING AND ADJUSTING THE STEERING HEAD" on page 3-21.

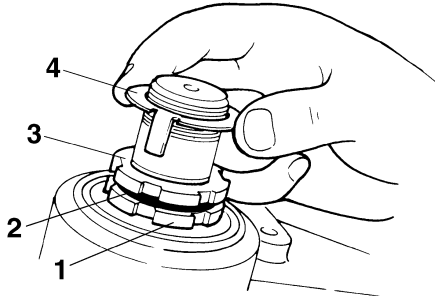

3. Install:
- Upper bracket
  - Steering stem nut

**TIP**

Temporarily tighten the steering stem nut.

4. Install:
- Front fork legs
- Refer to "FRONT FORK" on page 4-46.

**TIP**

Temporarily tighten the upper and lower bracket pinch bolts.

5. Tighten:
- Steering stem nut

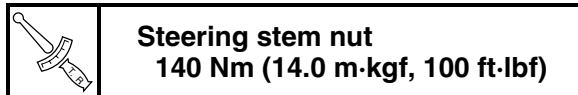

# YamahaR125.COM REAR SHOCK ABSORBER ASSEMBLY

EAS23160

## REAR SHOCK ABSORBER ASSEMBLY

### Removing the rear shock absorber assembly

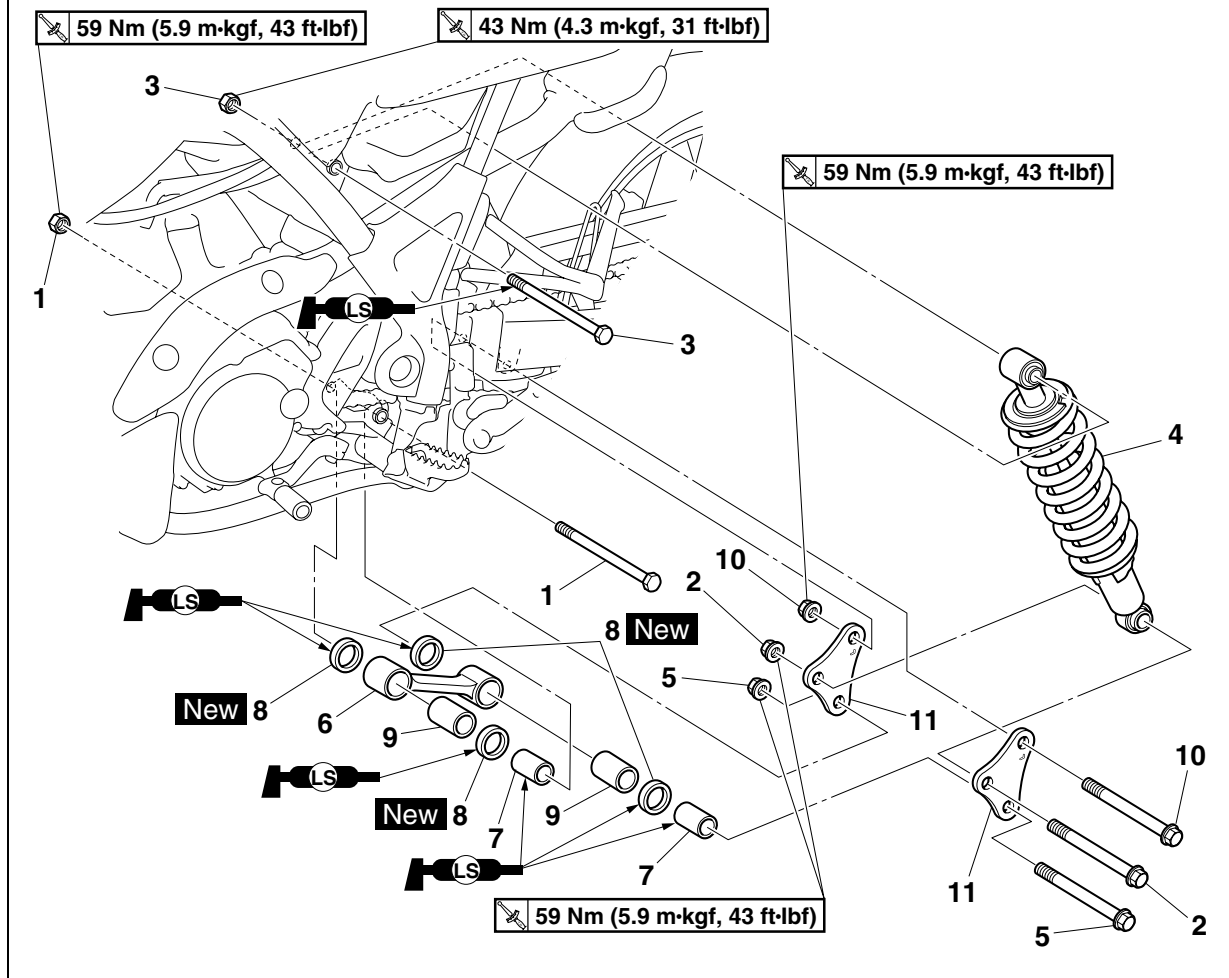

Order	Job/Parts to remove	Q'ty	Remarks
	Right rear side cover		Refer to "GENERAL CHASSIS" on page 4-1.
	Brake fluid reservoir bolt		Refer to "REAR BRAKE" on page 4-30.
1	Connecting rod front nut/ bolt	1/1	
2	Rear shock absorber assembly lower nut/bolt	1/1	
3	Rear shock absorber assembly upper nut/bolt	1/1	
4	Rear shock absorber assembly	1	
5	Connecting rod rear nut/ bolt	1/1	
6	Connecting rod	1	
7	Spacer	2	
8	Oil seal	4	
9	Bushing	2	
10	Relay arm nut/bolt	1/1	
11	Relay arm	2	
			For installation, reverse the removal procedure.

# YamahaR125.COM REAR SHOCK ABSORBER ASSEMBLY

EAS22B1041

## HANDLING THE REAR SHOCK ABSORBER ASSEMBLY (WR125R)

EWA22B1020

### **WARNING**

This rear shock absorber assembly contains highly compressed nitrogen gas. Before handling the rear shock absorber assembly, read and make sure you understand the following information. The manufacturer cannot be held responsible for property damage or personal injury that may result from improper handling of the rear shock absorber assembly.

- Do not tamper or attempt to open the rear shock absorber assembly.
- Do not subject the rear shock absorber assembly to an open flame or any other source of high heat. High heat can cause an explosion due to excessive gas pressure.
- Do not deform or damage the rear shock absorber assembly in any way. Rear shock absorber assembly damage will result in poor damping performance.

EAS22B1042

## DISPOSING OF A REAR SHOCK ABSORBER ASSEMBLY (WR125R)

1. Gas pressure must be released before disposing of a rear shock absorber assembly. To release the gas pressure, drill a 2–3 mm (0.08–0.12 in) hole through the rear shock absorber at a point 15–20 mm (0.59–0.79 in) from its end as shown.

EWA13760

### **WARNING**

Wear eye protection to prevent eye damage from released gas or metal chips.

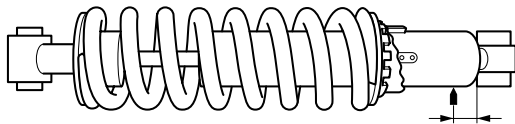

EAS23230

## REMOVING THE REAR SHOCK ABSORBER ASSEMBLY

1. Stand the vehicle on a level surface.

EWA13120

### **WARNING**

Securely support the vehicle so that there is no danger of it falling over.

### TIP

Place the vehicle on a suitable stand so that the rear wheel is elevated.

EAS23240

## CHECKING THE REAR SHOCK ABSORBER ASSEMBLY

1. Check:
  - Rear shock absorber rod  
Bends/damage → Replace the rear shock absorber assembly.
  - Rear shock absorber  
Gas leaks/oil leaks → Replace the rear shock absorber assembly.
  - Spring  
Damage/wear → Replace the rear shock absorber assembly.
  - Bushings  
Damage/wear → Replace the rear shock absorber assembly.
  - Bolts  
Bends/damage/wear → Replace.

EAS22B1031

## CHECKING THE CONNECTING ROD AND RELAY ARMS

1. Check:
  - Connecting rod  
Damage/wear → Replace.
2. Check:
  - Oil seals  
Damage/pitting → Replace.
3. Check:
  - Spacers  
Damage/scratches → Replace.
4. Check:
  - Bushings  
Damage/wear → Replace.

EAS22B1032

## INSTALLING THE RELAY ARMS AND CONNECTING ROD

1. Lubricate:
  - Spacers

# YamahaR125.COM REAR SHOCK ABSORBER ASSEMBLY



## 2. Install:

- Oil seals “1”  
(to the connecting rod)

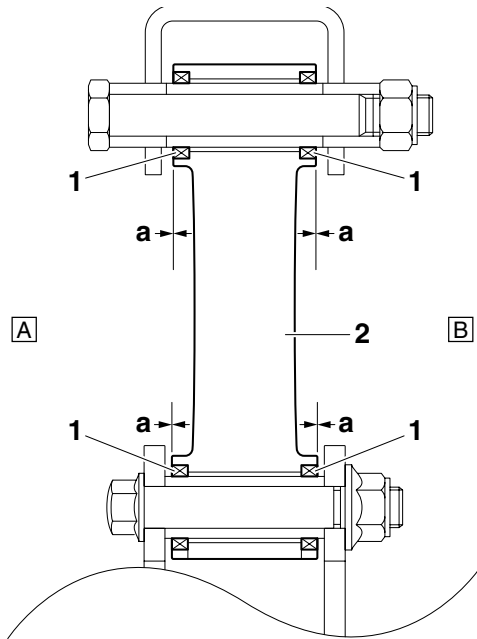
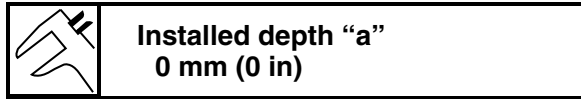

2. Connecting rod

A. Left side

B. Right side

## 3. Install:

- Relay arms “1”

### TIP

Be sure to face the “L” mark “a” on both of the relay arms to the left.

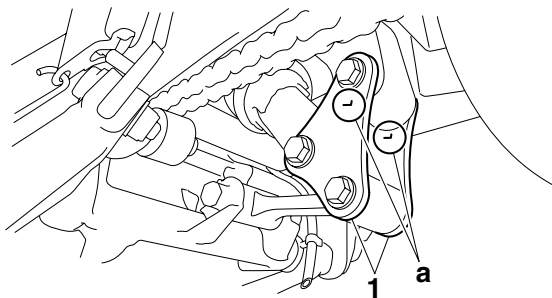

EAS23330

## SWINGARM

### Removing the swingarm

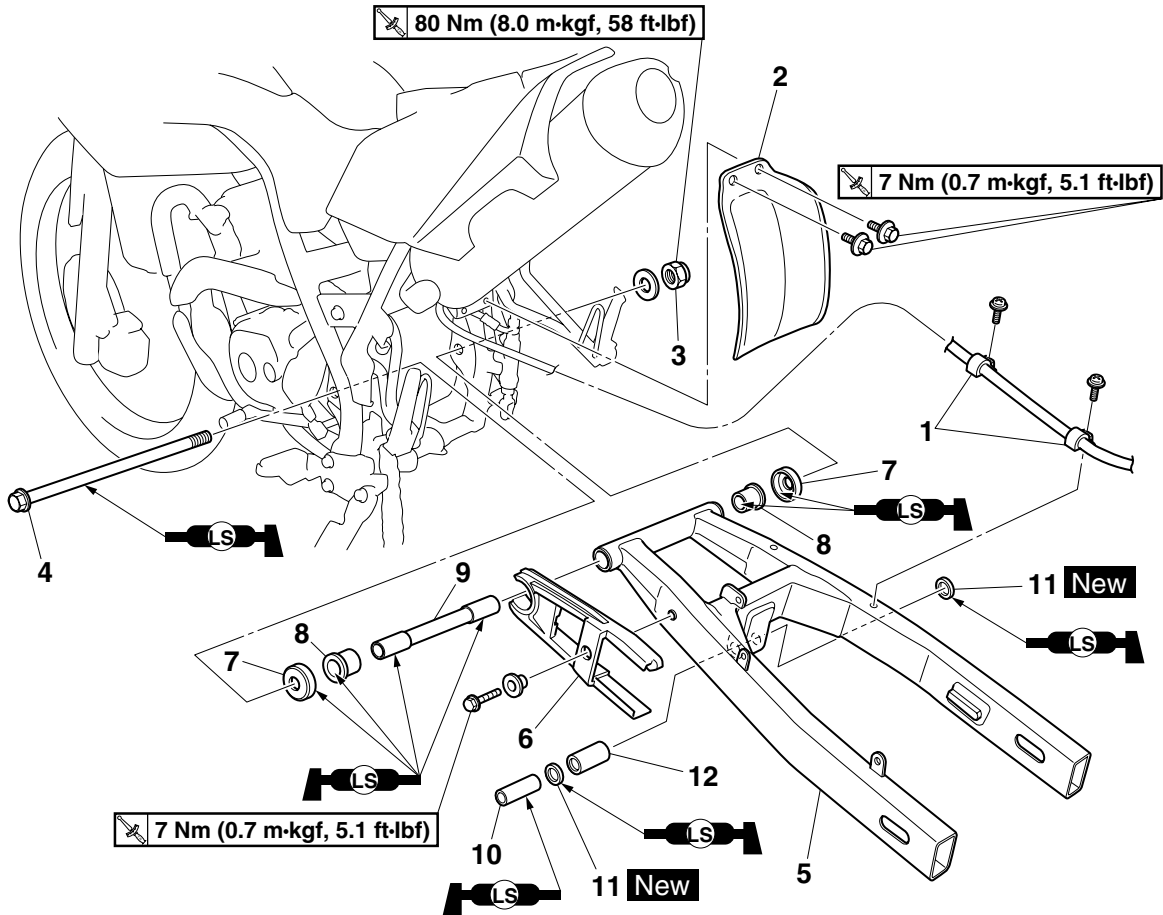

Order	Job/Parts to remove	Q'ty	Remarks
	Side panels		Refer to "GENERAL CHASSIS" on page 4-1.
	Rear wheel		Refer to "REAR WHEEL" on page 4-13.
	Rear shock absorber assembly/Relay arm		Refer to "REAR SHOCK ABSORBER ASSEMBLY" on page 4-60.
1	Rear brake hose holder	2	
2	Rear mudguard	1	
3	Pivot shaft nut	1	
4	Pivot shaft	1	
5	Swingarm	1	
6	Drive chain guide	1	
7	Dust cover	2	
8	Bushing	2	
9	Bushing	1	
10	Spacer	1	
11	Oil seal	2	

Removing the swingarm

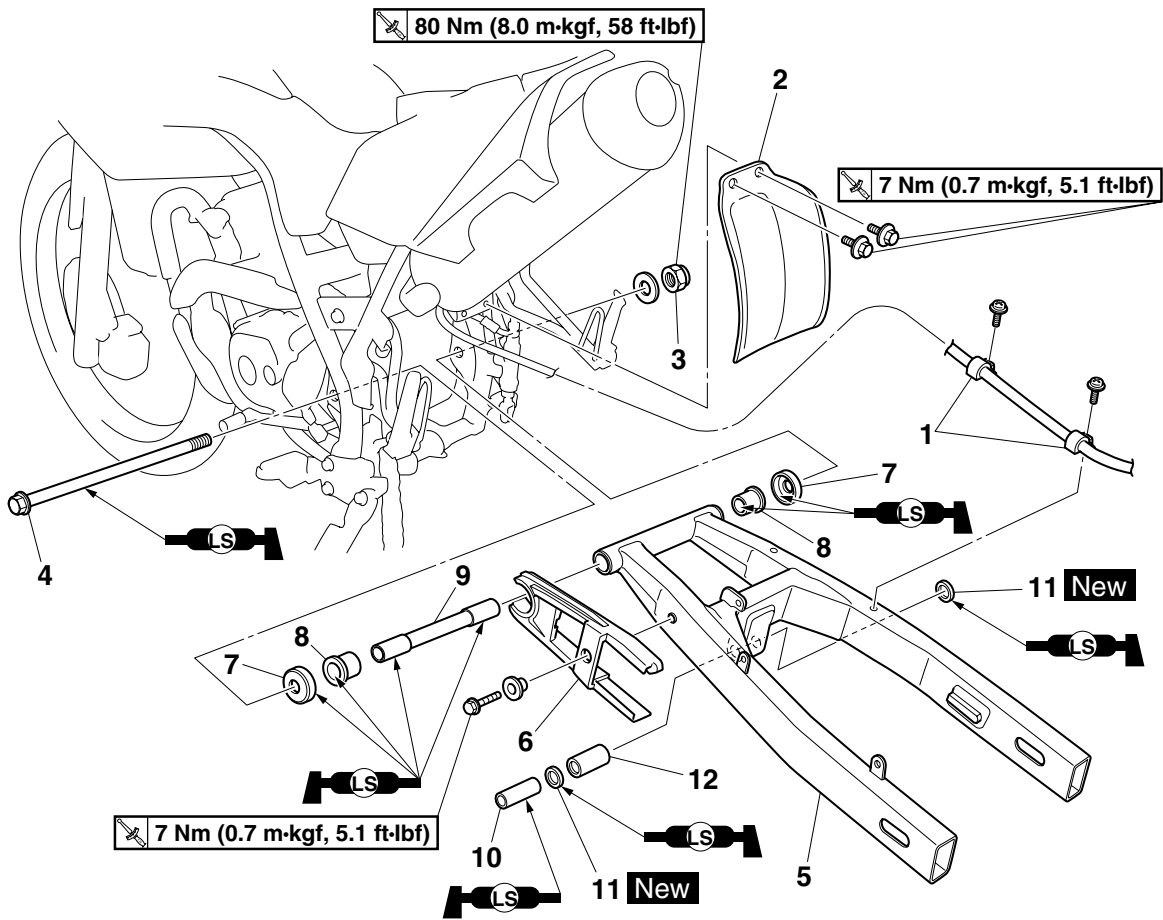

Order	Job/Parts to remove	Q'ty	Remarks
12	Bushing	1	
			For installation, reverse the removal procedure.

EAS23350

## REMOVING THE SWINGARM

- Stand the vehicle on a level surface.

EWA13120

### WARNING

Securely support the vehicle so that there is no danger of it falling over.

- Measure:

- Swingarm side play
- Swingarm vertical movement

- Measure the tightening torque of the pivot shaft nut.

	<b>Pivot shaft nut</b> 80 Nm (8.0 m·kgf, 58 ft·lbf)
---	--

- Measure the swingarm side play "A" by moving the swingarm from side to side.
- If the swingarm side play is out of specification, check the bushings and dust covers.

	<b>Swingarm end free play limit (axial)</b> 0 mm (0 in)
--	--

- Check the swingarm vertical movement "B" by moving the swingarm up and down. If swingarm vertical movement is not smooth or if there is binding, check the bushings and dust covers.

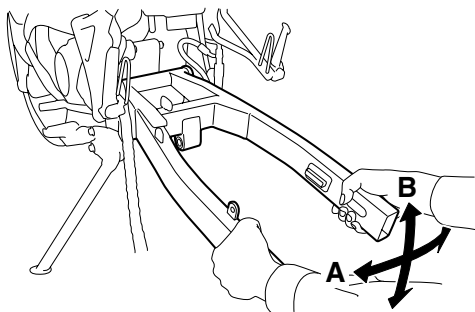

EAS23360

## CHECKING THE SWINGARM

- Check:
  - Swingarm  
Bends/cracks/damage → Replace.
- Check:
  - Pivot shaft  
Roll the pivot shaft on a flat surface.  
Bends → Replace.

EWA13770

### WARNING

Do not attempt to straighten a bent pivot shaft.

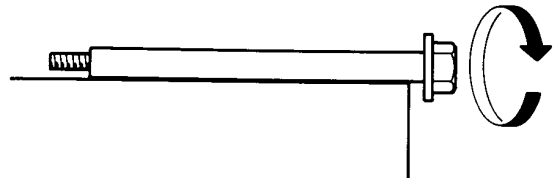

- Wash:

- Pivot shaft
- Dust covers
- Bushings

	<b>Recommended cleaning solvent</b> Kerosene
---	---

- Check:

- Dust covers
  - Bushings
- Damage/wear → Replace.

EAS23380

## INSTALLING THE SWINGARM

- Lubricate:

- Spacer
- Oil seals
- Bushings
- Dust covers
- Pivot shaft

	<b>Recommended lubricant</b> Lithium-soap-based grease
---	---

- Install:

- Oil seals "1"  
(to the swingarm)

	<b>Installed depth "a"</b> 0 mm (0 in)
---	---



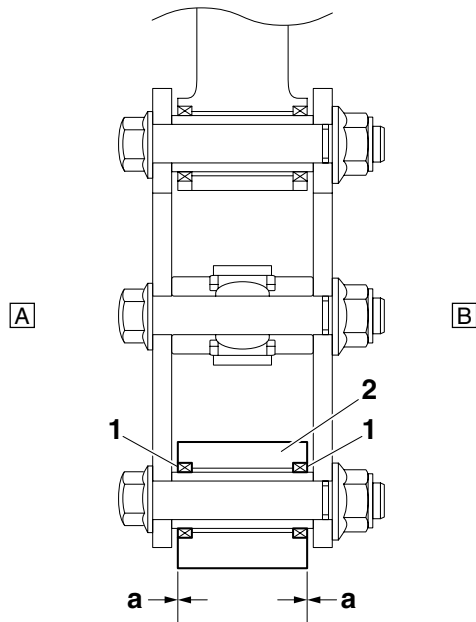

2. Swingarm  
 A. Left side  
 B. Right side

3. Adjust:
- Drive chain slack  
 Refer to "ADJUSTING THE DRIVE CHAIN SLACK" on page 3-20.



ECA13550

**NOTICE**

**A drive chain that is too tight will overload the engine and other vital parts, and one that is too loose can skip and damage the swingarm or cause an accident. Therefore, keep the drive chain slack within the specified limits.**

EAS23400

## CHAIN DRIVE

### Removing the drive chain

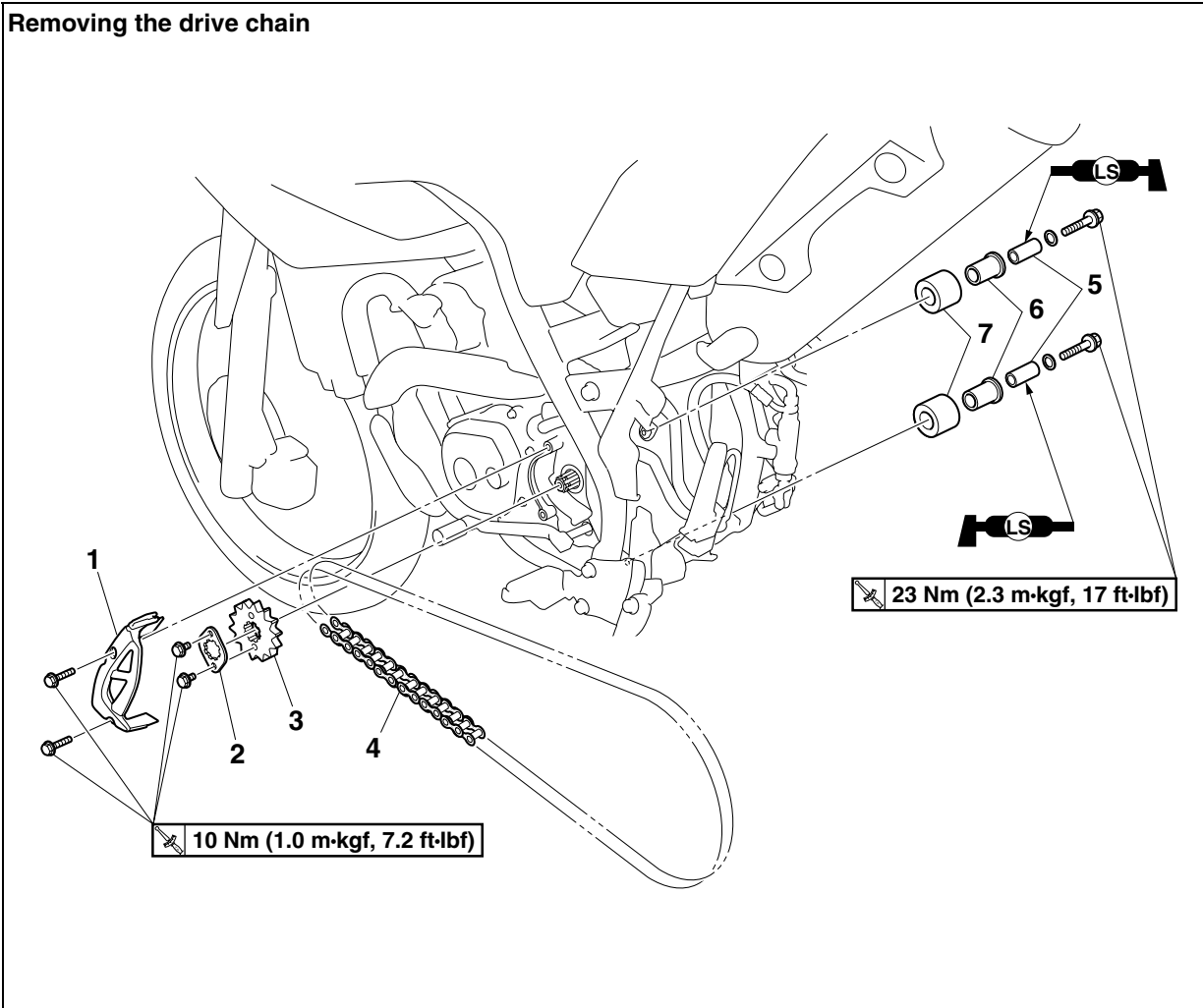

Order	Job/Parts to remove	Q'ty	Remarks
	Swingarm		Refer to "SWINGARM" on page 4-63.
1	Drive sprocket cover	1	
2	Drive sprocket retainer	1	
3	Drive sprocket	1	
4	Drive chain	1	
5	Spacer	2	
6	Bush	2	
7	Chain tensioner	2	
			For installation, reverse the removal procedure.

EAS23410

## REMOVING THE DRIVE CHAIN

- Stand the vehicle on a level surface.

EWA13120

### **WARNING**

Securely support the vehicle so that there is no danger of it falling over.

### TIP

Place the vehicle on a suitable stand so that the rear wheel is elevated.

EAS23441

## CHECKING THE DRIVE CHAIN

- Measure:

- 15-link section "a" of the drive chain
- Out of specification → Replace the drive chain.

	<b>15-link length limit</b> 191.5 mm (7.54 in)
---	---

- Measure the length "a" between the inner sides of the pins and the length "b" between the outer sides of the pins on a 15-link section of the drive chain as shown in the illustration.

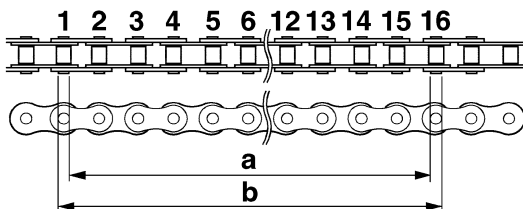

- Calculate the length "c" of the 15-link section of the drive chain using the following formula.  
Drive chain 15-link section length "c" = (length "a" between pin inner sides + length "b" between pin outer sides)/2

### TIP

- When measuring a 15-link section of the drive chain, make sure that the drive chain is taut.
- Perform this procedure 2–3 times, at a different location each time.

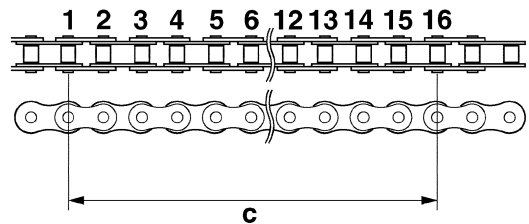

- Check:

- Drive chain
- Stiffness → Clean and lubricate or replace.

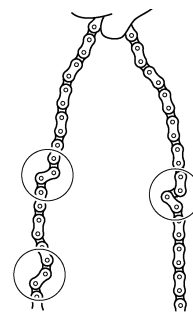

- Clean:

- Drive chain

- Wipe the drive chain with a clean cloth.
- Put the drive chain in kerosene and remove any remaining dirt.
- Remove the drive chain from the kerosene and completely dry it.

ECA22B1025

### **NOTICE**

- This vehicle has a drive chain with small rubber O-rings "1" between the drive chain side plates. Never use high-pressure water or air, steam, gasoline, certain solvents (e.g., benzene), or a coarse brush to clean the drive chain. High-pressure methods could force dirt or water into the drive chain's internals, and solvents will deteriorate the O-rings. A coarse brush can also damage the O-rings. Therefore, use only kerosene to clean the drive chain.
- Do not soak the drive chain in kerosene for more than ten minutes, otherwise the O-rings can be damaged.

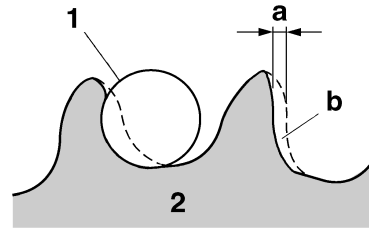
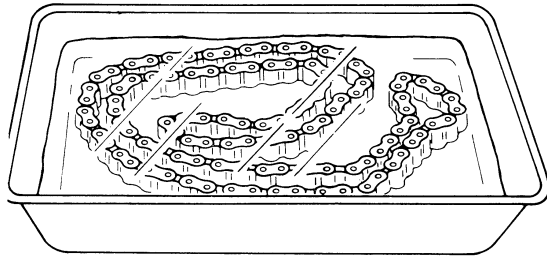

- b. Correct
1. Drive chain roller
  2. Drive sprocket

EAS23470

### CHECKING THE REAR WHEEL SPROCKET

Refer to "CHECKING AND REPLACING THE REAR WHEEL SPROCKET" on page 4-17

EAS28800

### INSTALLING THE DRIVE CHAIN

1. Lubricate:
  - Drive chain

	<b>Recommended lubricant</b> <b>Engine oil or chain lubricant</b> <b>suitable for O-ring chains</b>
--	---

2. Install:
  - Drive sprocket cover "1"

	<b>Drive sprocket cover bolt</b> <b>10 Nm (1.0 m·kgf, 7.2 ft·lbf)</b>
--	--

#### TIP

- Be sure not to pinch the neutral switch lead when installing the drive sprocket cover.
- Pass the sidestand switch lead "2" through the groove "a" in the drive sprocket cover.



4. Check:
  - O-rings "1"  
Damage → Replace the drive chain.
  - Drive chain rollers "2"  
Damage/wear → Replace the drive chain.
  - Drive chain side plates "3"  
Damage/wear → Replace the drive chain.  
Cracks → Replace the drive chain.

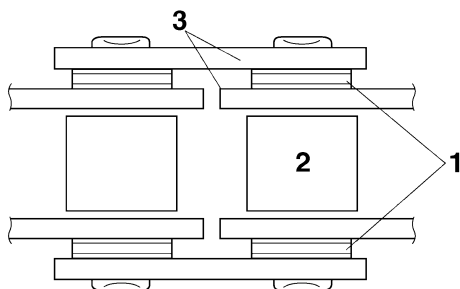

5. Lubricate:
  - Drive chain

	<b>Recommended lubricant</b> <b>Engine oil or chain lubricant</b> <b>suitable for O-ring chains</b>
--	---

EAS23460

### CHECKING THE DRIVE SPROCKET

1. Check:
  - Drive sprocket  
More than 1/4 tooth "a" wear → Replace the drive sprocket.  
Bent teeth → Replace the drive sprocket.

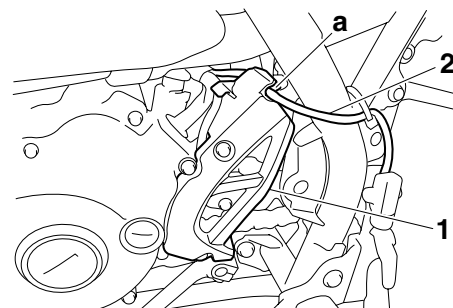

3. Adjust:
  - Drive chain slack  
Refer to "ADJUSTING THE DRIVE CHAIN SLACK" on page 3-20.



**Drive chain slack**  
40.0–50.0 mm (1.57–1.97 in)

ECA13550

**NOTICE**

**A drive chain that is too tight will overload the engine and other vital parts, and one that is too loose can skip and damage the swing-arm or cause an accident. Therefore, keep the drive chain slack within the specified limits.**

---



## ENGINE

<b>ENGINE REMOVAL</b> .....	5-1
REMOVING THE ENGINE .....	5-5
INSTALLING THE ENGINE.....	5-5
INSTALLING THE RIDER FOOTREST/BRAKE PEDAL BRACKET ASSEMBLY .....	5-5
INSTALLING THE SHIFT PEDAL .....	5-6
INSTALLING THE MUFFLER AND EXHAUST PIPE.....	5-6
<b>CYLINDER HEAD</b> .....	5-7
REMOVING THE CYLINDER HEAD.....	5-9
CHECKING THE CYLINDER HEAD .....	5-9
CHECKING THE CAMSHAFT SPROCKET AND TIMING CHAIN GUIDE .....	5-10
CHECKING THE TIMING CHAIN TENSIONER.....	5-10
CHECKING THE DECOMPRESSION SYSTEM.....	5-11
INSTALLING THE CYLINDER HEAD .....	5-11
<b>CAMSHAFT</b> .....	5-14
CHECKING THE CAMSHAFT.....	5-15
CHECKING THE ROCKER ARMS AND ROCKER ARM SHAFTS .....	5-15
INSTALLING THE CAMSHAFT AND ROCKER ARMS .....	5-16
<b>VALVES AND VALVE SPRINGS</b> .....	5-17
REMOVING THE VALVES.....	5-18
CHECKING THE VALVES AND VALVE GUIDES .....	5-18
CHECKING THE VALVE SEATS.....	5-20
CHECKING THE VALVE SPRINGS.....	5-21
INSTALLING THE VALVES .....	5-22
<b>CYLINDER AND PISTON</b> .....	5-24
REMOVING THE PISTON .....	5-25
CHECKING THE CYLINDER AND PISTON .....	5-25
CHECKING THE PISTON RINGS.....	5-26
CHECKING THE PISTON PIN .....	5-27
INSTALLING THE PISTON AND CYLINDER .....	5-27
<b>GENERATOR AND STARTER CLUTCH</b> .....	5-29
REMOVING THE GENERATOR .....	5-31
REMOVING THE STARTER CLUTCH .....	5-31
CHECKING THE STARTER CLUTCH .....	5-32
INSTALLING THE STARTER CLUTCH .....	5-32
INSTALLING THE GENERATOR.....	5-32
<b>ELECTRIC STARTER</b> .....	5-34
CHECKING THE STARTER MOTOR .....	5-36
ASSEMBLING THE STARTER MOTOR.....	5-37

<b>CLUTCH</b> .....	5-38
REMOVING THE CLUTCH .....	5-42
CHECKING THE FRICTION PLATES.....	5-42
CHECKING THE CLUTCH PLATES .....	5-43
CHECKING THE CLUTCH SPRINGS.....	5-43
CHECKING THE CLUTCH HOUSING .....	5-43
CHECKING THE CLUTCH BOSS.....	5-43
CHECKING THE PRESSURE PLATE .....	5-44
CHECKING THE CLUTCH PUSH LEVER AND SHORT CLUTCH PUSH ROD .....	5-44
CHECKING THE PRIMARY DRIVE GEAR.....	5-44
CHECKING THE PRIMARY DRIVEN GEAR .....	5-44
INSTALLING THE CLUTCH.....	5-44
<b>OIL PUMP</b> .....	5-47
CHECKING THE OIL PUMP .....	5-49
ASSEMBLING THE OIL PUMP .....	5-49
INSTALLING THE OIL PUMP .....	5-50
<b>SHIFT SHAFT</b> .....	5-51
CHECKING THE SHIFT SHAFT .....	5-52
CHECKING THE STOPPER LEVER .....	5-52
INSTALLING THE SHIFT SHAFT .....	5-52
<b>BALANCER GEARS</b> .....	5-53
REMOVING THE PRIMARY DRIVE GEAR AND BALANCER GEARS.....	5-54
CHECKING THE BALANCER GEARS AND PRIMARY DRIVE GEAR .....	5-54
INSTALLING THE PRIMARY DRIVE GEAR AND BALANCER GEARS.....	5-54
<b>CRANKCASE</b> .....	5-56
SEPARATING THE CRANKCASE.....	5-59
CHECKING THE CRANKCASE .....	5-59
CHECKING THE TIMING CHAIN AND TIMING CHAIN GUIDE.....	5-59
CHECKING THE OIL STRAINER .....	5-59
CHECKING THE BEARINGS AND OIL SEAL .....	5-59
INSTALLING THE BEARING RETAINER .....	5-60
INSTALLING THE OIL SEAL .....	5-60
ASSEMBLING THE CRANKCASE.....	5-60
<b>CRANKSHAFT</b> .....	5-62
REMOVING THE CRANKSHAFT .....	5-63
CHECKING THE CRANKSHAFT .....	5-63
INSTALLING THE CRANKSHAFT .....	5-63



<b>TRANSMISSION</b> .....	5-65
CHECKING THE SHIFT FORKS.....	5-68
CHECKING THE SHIFT DRUM ASSEMBLY .....	5-68
CHECKING THE TRANSMISSION .....	5-68
CHECKING THE LONG CLUTCH PUSH ROD.....	5-69
ASSEMBLING THE MAIN AXLE AND DRIVE AXLE .....	5-69
INSTALLING THE SHIFT FORKS AND SHIFT DRUM ASSEMBLY .....	5-69

EAS23711

## ENGINE REMOVAL

### Removing the muffler and exhaust pipe

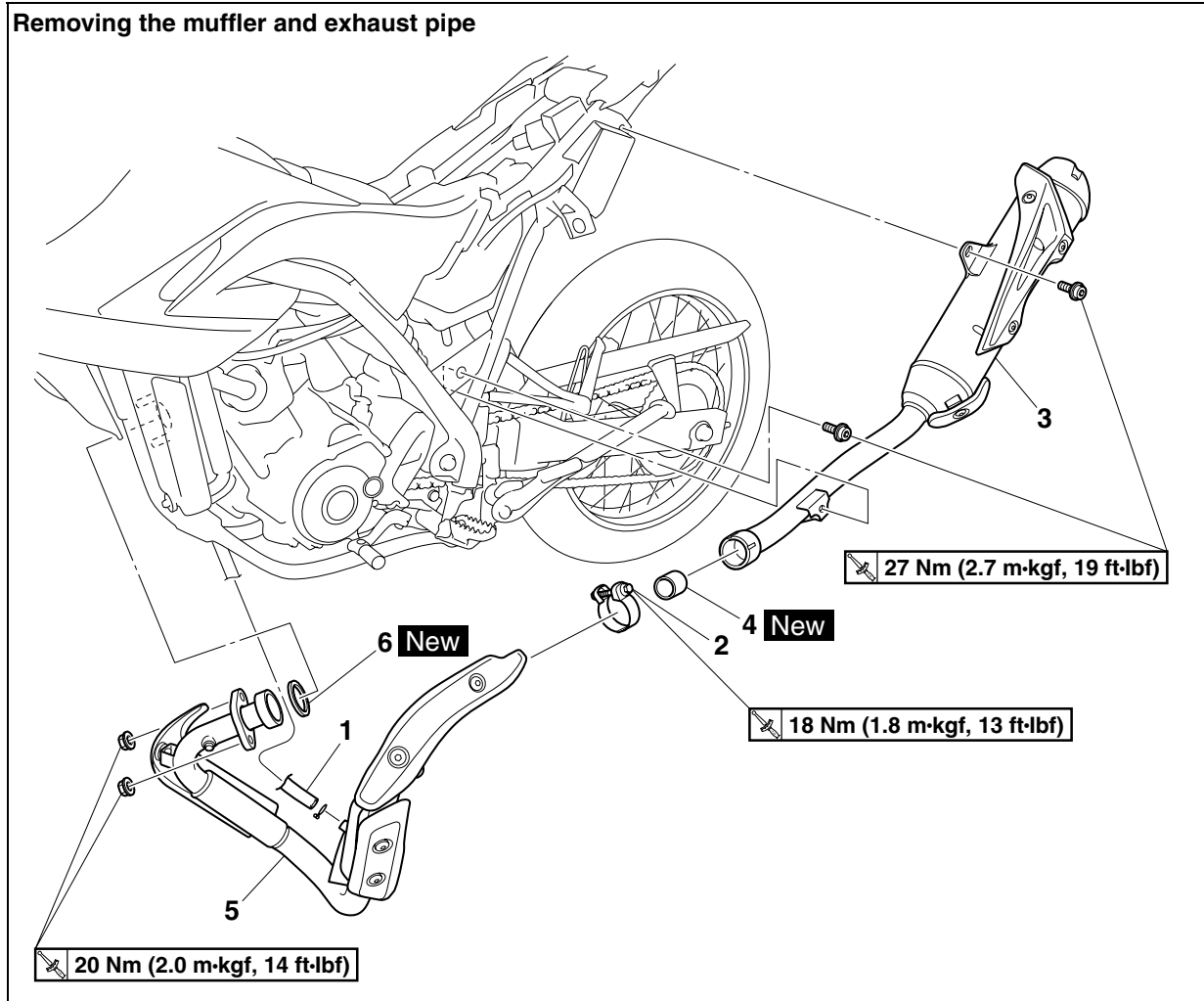

Order	Job/Parts to remove	Q'ty	Remarks
	Left side panel/Left rear side cover		Refer to "GENERAL CHASSIS" on page 4-1.
1	Air induction system hose (reed valve assembly to exhaust pipe)	1	Disconnect.
2	Muffler clamp bolt	1	Loosen.
3	Muffler	1	
4	Gasket	1	
5	Exhaust pipe	1	
6	Gasket	1	
			For installation, reverse the removal procedure.

## Disconnecting the leads and couplers

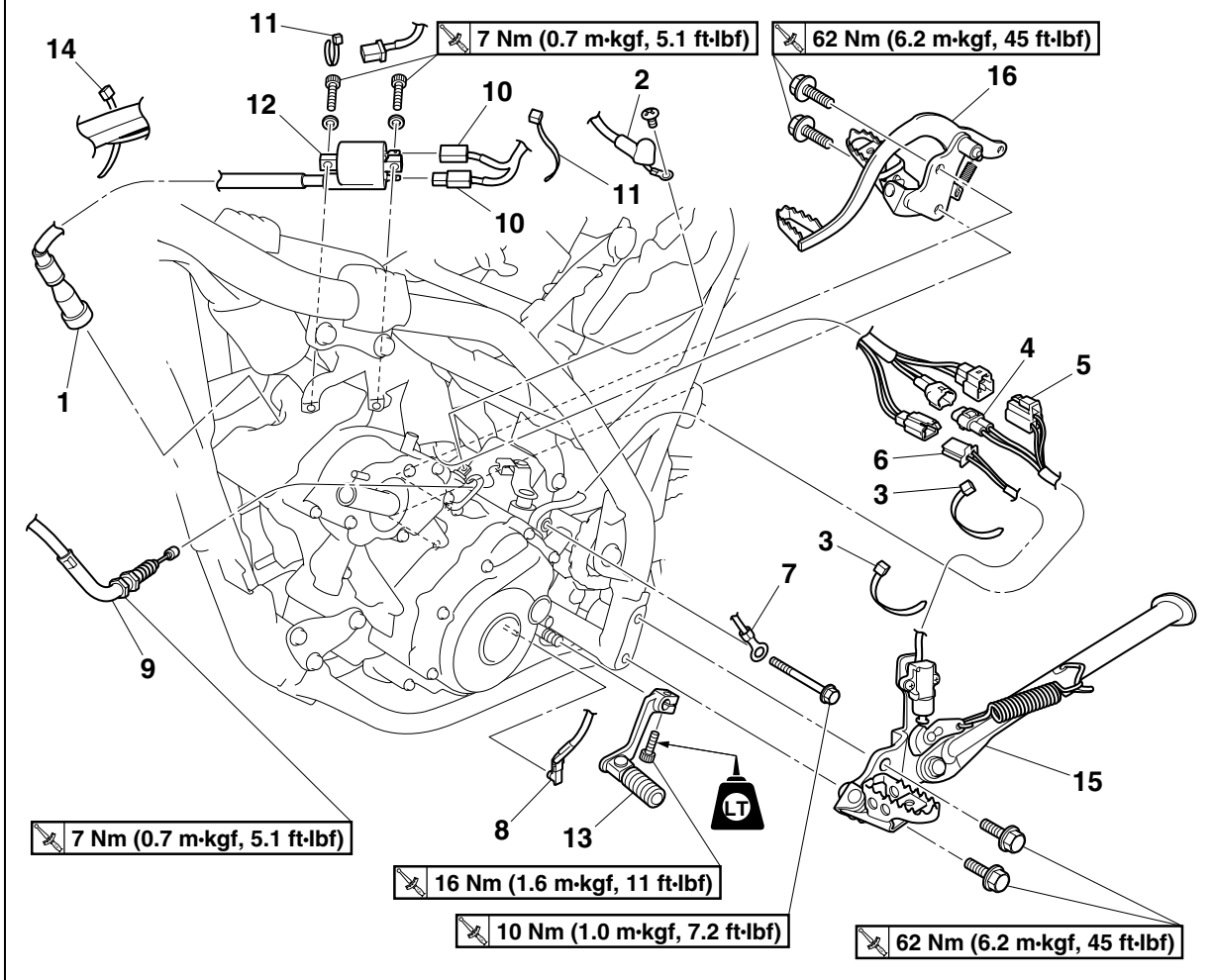

Order	Job/Parts to remove	Q'ty	Remarks
	Seat/Fuel tank cover assembly/Air filter case		Refer to "GENERAL CHASSIS" on page 4-1.
	Engine oil		Drain. Refer to "CHANGING THE ENGINE OIL" on page 3-10.
	Coolant		Drain. Refer to "CHANGING THE COOLANT" on page 3-15.
	Fuel tank		Refer to "FUEL TANK" on page 7-1.
	Throttle body/Intake manifold		Refer to "THROTTLE BODY" on page 7-5.
	Coolant reservoir hose/Water pump breather hose/Radiator hoses/Radiator bracket		Refer to "RADIATOR" on page 6-1.
	Coolant temperature sensor		Refer to "THERMOSTAT" on page 6-4.
	Cylinder head breather hose		Refer to "WATER PUMP" on page 6-6.
	Air induction system reed valve assembly		Refer to "AIR INDUCTION SYSTEM" on page 7-9.
	Drive sprocket cover/Drive sprocket		Refer to "CHAIN DRIVE" on page 4-67.
1	Spark plug cap	1	Disconnect.
2	Starter motor lead	1	Disconnect.
3	Plastic locking tie	2	

## Disconnecting the leads and couplers

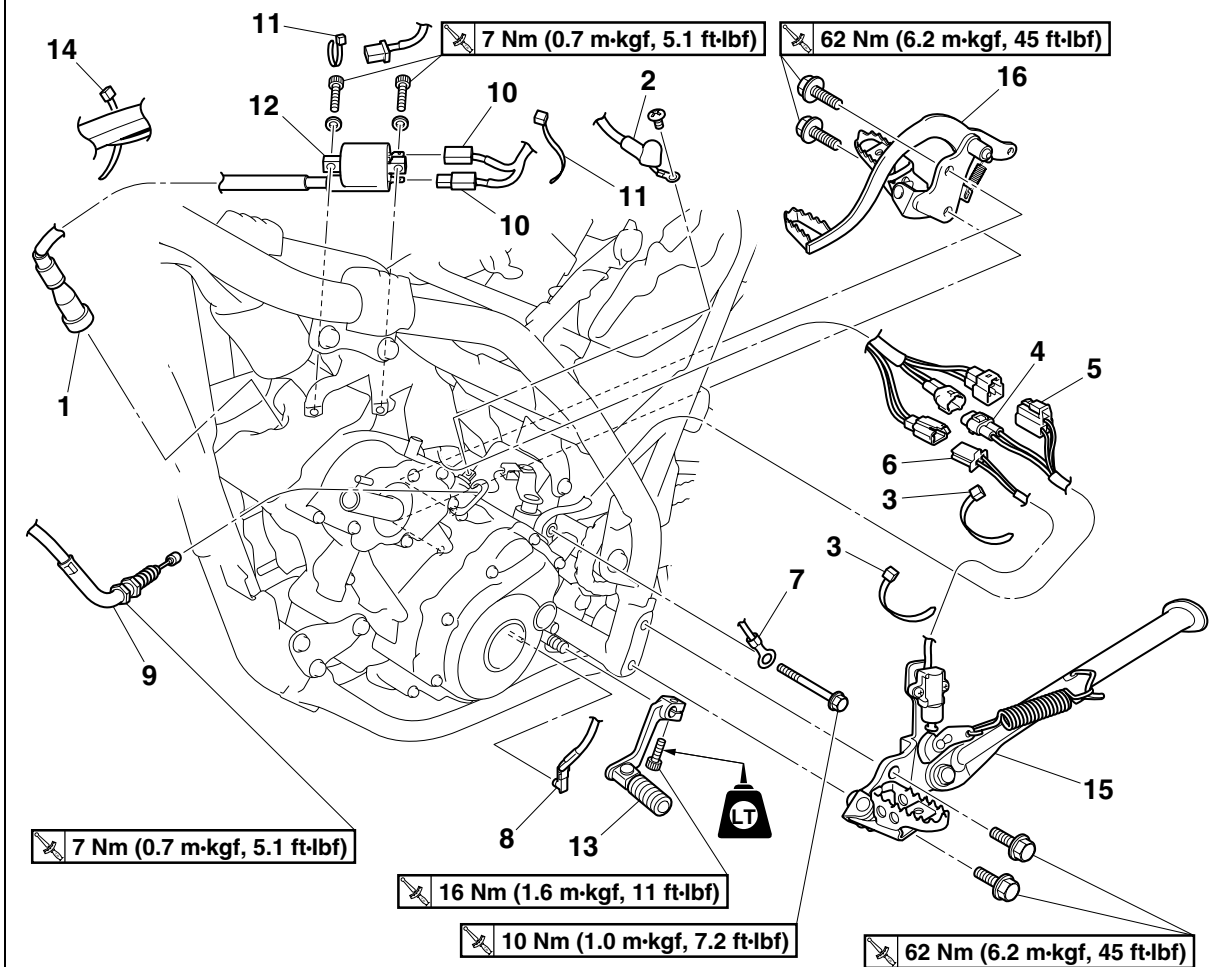

Order	Job/Parts to remove	Q'ty	Remarks
4	Crankshaft position sensor coupler	1	Disconnect.
5	Stator coil coupler	1	Disconnect.
6	Sidestand switch coupler	1	Disconnect.
7	Negative battery lead	1	Disconnect.
8	Neutral switch connector	1	Disconnect.
9	Clutch cable	1	Disconnect.
10	Ignition coil connector	2	Disconnect.
11	Plastic locking tie	2	
12	Ignition coil	1	
13	Shift pedal	1	
14	Plastic locking tie	1	
15	Rider footrest/sidestand bracket assembly	1	
16	Rider footrest/brake pedal bracket assembly	1	
			For installation, reverse the removal procedure.

## Removing the engine

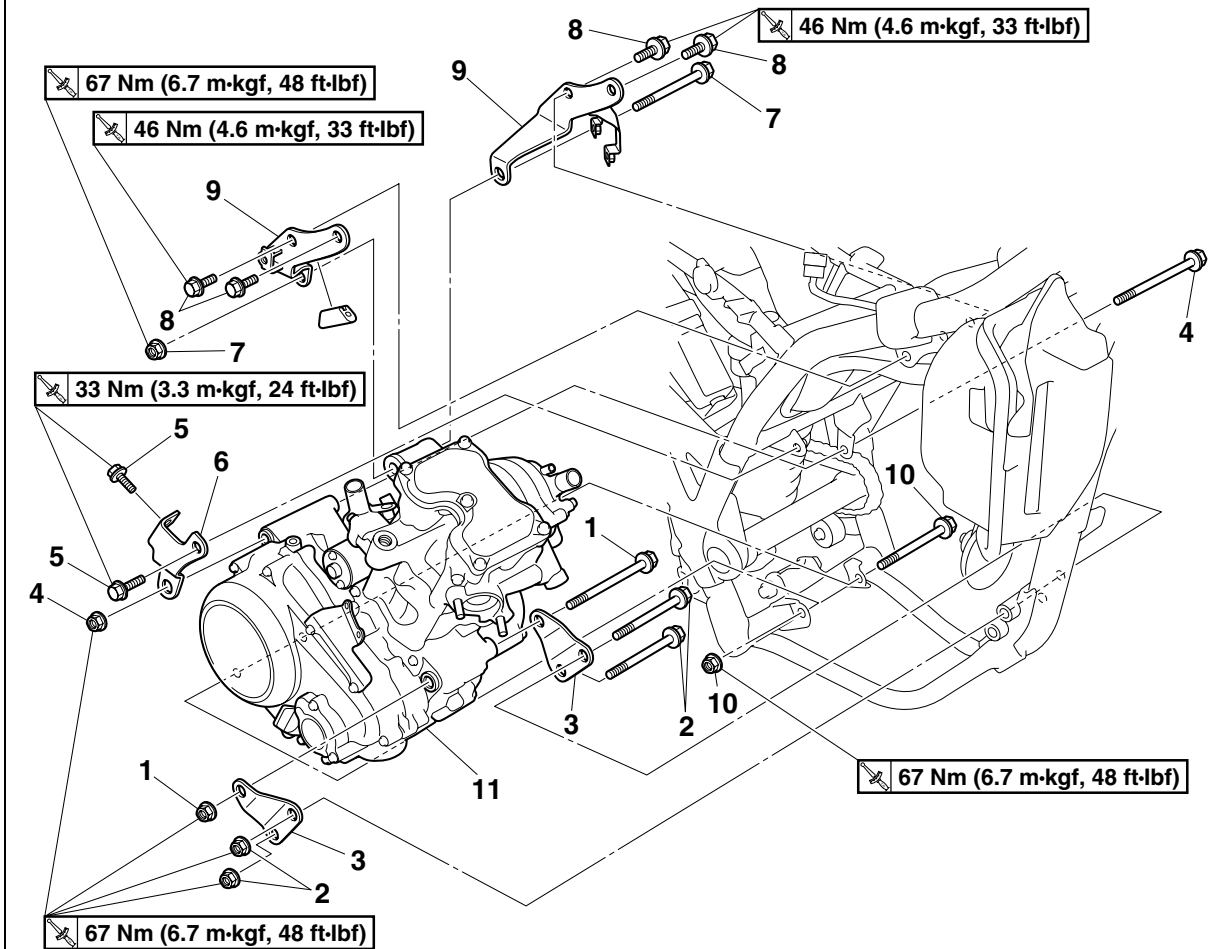

Order	Job/Parts to remove	Q'ty	Remarks
1	Engine front lower mounting bolt/nut	1/1	
2	Engine front lower bracket bolt/nut	2/2	
3	Engine front lower bracket	2	
4	Engine rear upper mounting bolt/nut	1/1	
5	Engine rear bracket bolt	2	
6	Engine rear bracket	1	
7	Engine front upper mounting bolt/nut	1/1	
8	Engine front upper bracket bolt	4	
9	Engine front upper bracket	2	
10	Engine rear lower mounting bolt/nut	1/1	
11	Engine	1	
			For installation, reverse the removal procedure.

EAS22B1039

## REMOVING THE ENGINE

- Remove:
  - Engine

ECA22B1028

### NOTICE

When removing the engine, be careful not to pull on or damage the wire harness and battery breather hose with the engine.

### TIP

Remove the engine from the right side of the vehicle.

EAS23720

## INSTALLING THE ENGINE

- Install:
  - Engine "1"
  - Engine rear lower mounting bolt "2"
  - Engine rear lower mounting nut "3"
  - Engine front upper brackets "4"
  - Engine front upper bracket bolts "5"
  - Engine front upper mounting bolt "6"
  - Engine front upper mounting nut "7"
  - Engine rear bracket "8"
  - Engine rear bracket bolts "9"
  - Engine rear upper mounting bolt "10"
  - Engine rear upper mounting nut "11"
  - Engine front lower brackets "12"
  - Engine front lower bracket bolts "13"
  - Engine front lower bracket nuts "14"
  - Engine front lower mounting bolt "15"
  - Engine front lower mounting nut "16"

ECA22B1029

### NOTICE

When installing the engine, be careful not to pull on or damage the wire harness and battery breather hose with the engine.

### TIP

Do not fully tighten the nuts and bolts.

- Tighten:
  - Engine rear lower mounting nut "3"



**Engine rear lower mounting nut**  
67 Nm (6.7 m·kgf, 48 ft·lbf)

- Engine front upper bracket bolts "5"



**Engine front upper bracket bolt**  
46 Nm (4.6 m·kgf, 33 ft·lbf)

- Engine front upper mounting nut "7"



**Engine front upper mounting nut**  
67 Nm (6.7 m·kgf, 48 ft·lbf)

- Engine rear bracket bolts "9"



**Engine rear bracket bolt**  
33 Nm (3.3 m·kgf, 24 ft·lbf)

- Engine rear upper mounting nut "11"



**Engine rear upper mounting nut**  
67 Nm (6.7 m·kgf, 48 ft·lbf)

- Engine front lower bracket nuts "14"



**Engine front lower bracket nut**  
67 Nm (6.7 m·kgf, 48 ft·lbf)

- Engine front lower mounting nut "16"



**Engine front lower mounting nut**  
67 Nm (6.7 m·kgf, 48 ft·lbf)

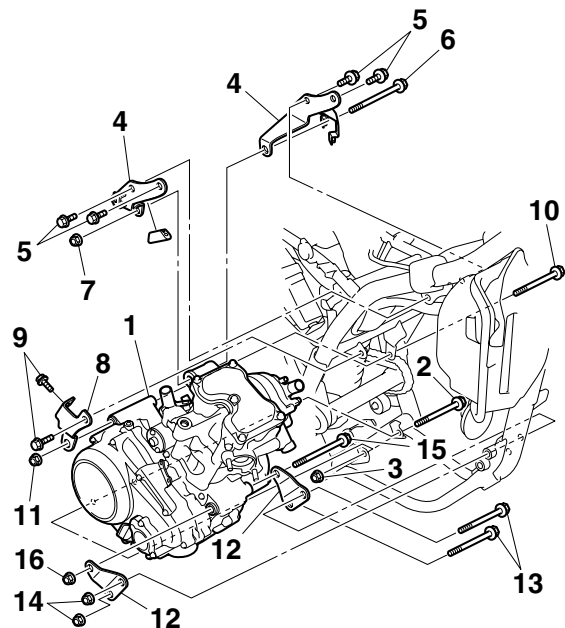

EAS22B1040

## INSTALLING THE RIDER FOOTREST/BRAKE PEDAL BRACKET ASSEMBLY

- Install:
  - Rider footrest/brake pedal bracket assembly



**Rider footrest/brake pedal bracket assembly bolt**  
62 Nm (6.2 m·kgf, 45 ft·lbf)

2. Check:

- Brake pedal position  
Refer to "ADJUSTING THE REAR DISC BRAKE" on page 3-17.

	<b>Brake pedal position</b> 12.0 mm (0.47 in)
---	--

EAS22B1027

### INSTALLING THE SHIFT PEDAL

1. Install:

- Shift pedal "1"

	<b>Shift pedal bolt</b> 16 Nm (1.6 m·kgf, 11 ft·lbf) LOCTITE®
---	---

**TIP**

Install the shift pedal so that its end is positioned in the range "a" shown in the illustration.

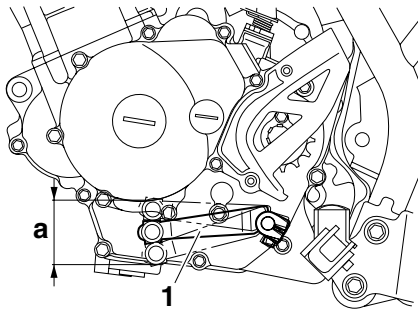

EAS22B1028

### INSTALLING THE MUFFLER AND EXHAUST PIPE

1. Install:

- Gaskets **New**
- Exhaust pipe
- Muffler clamp
- Muffler

**TIP**

Do not fully tighten the nuts and bolts.

2. Tighten:

- Exhaust pipe nuts "1"

	<b>Exhaust pipe nut</b> 20 Nm (2.0 m·kgf, 14 ft·lbf)
---	---

- Muffler bolts "2"

	<b>Muffler bolt</b> 27 Nm (2.7 m·kgf, 19 ft·lbf)
---	---

- Muffler clamp bolt "3"

	<b>Muffler clamp bolt</b> 18 Nm (1.8 m·kgf, 13 ft·lbf)
---	---

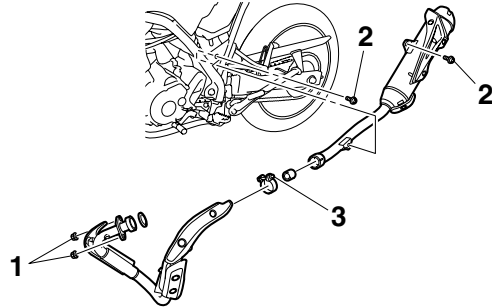

EAS24100

## CYLINDER HEAD

### Removing the cylinder head

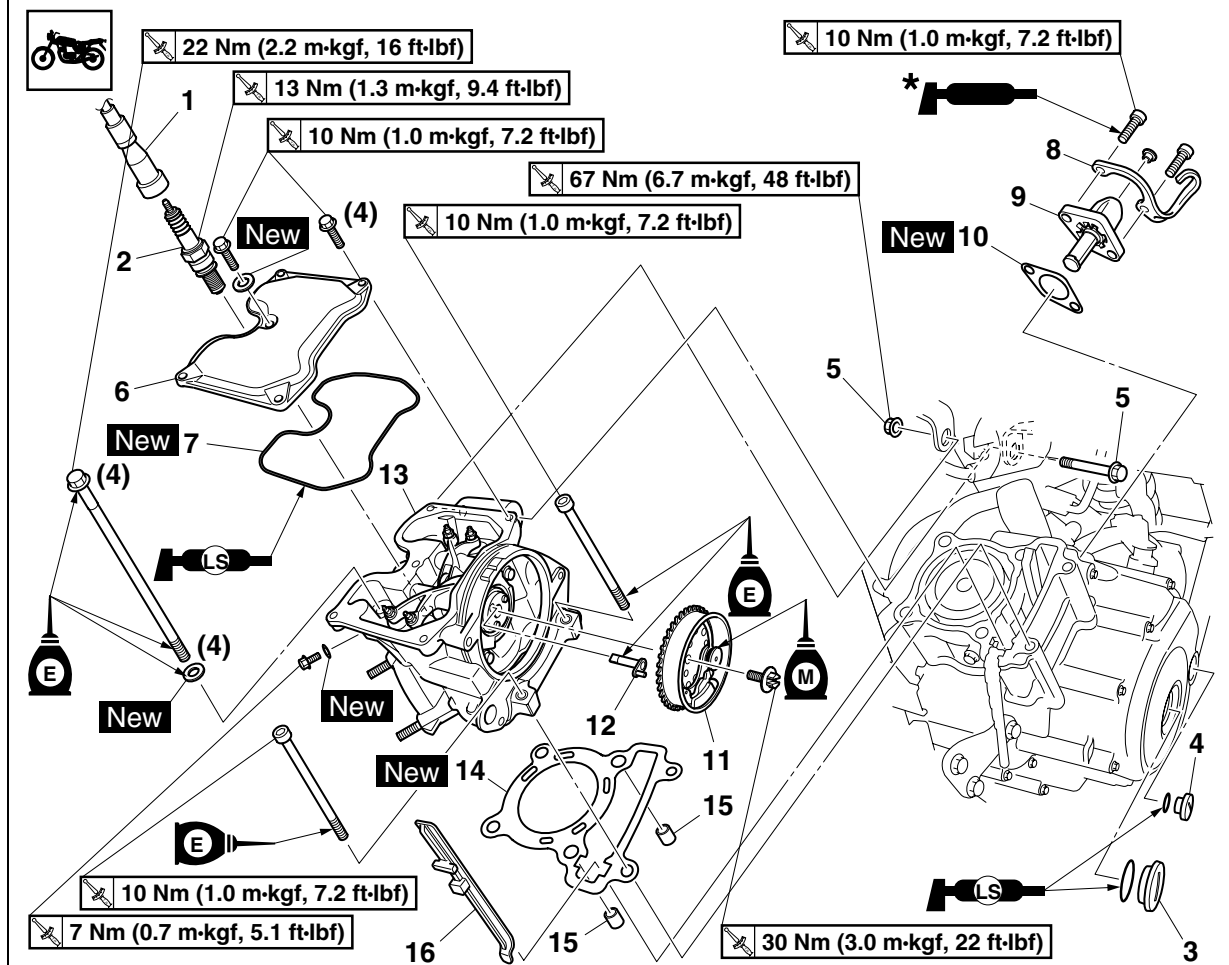

Order	Job/Parts to remove	Q'ty	Remarks
	Seat/Fuel tank cover assembly/Air filter case		Refer to "GENERAL CHASSIS" on page 4-1.
	Coolant		Drain. Refer to "CHANGING THE COOLANT" on page 3-15.
	Muffler/Exhaust pipe		Refer to "ENGINE REMOVAL" on page 5-1.
	Clutch cable		Disconnect. Refer to "CLUTCH" on page 5-38.
	Fuel tank		Refer to "FUEL TANK" on page 7-1.
	Throttle body/Intake manifold		Refer to "THROTTLE BODY" on page 7-5.
	Radiator		Refer to "RADIATOR" on page 6-1.
	Thermostat/Coolant temperature sensor		Refer to "THERMOSTAT" on page 6-4.
	Water pump		Refer to "WATER PUMP" on page 6-6.
1	Spark plug cap	1	Disconnect.
2	Spark plug	1	
3	Crankshaft end accessing screw	1	
4	Timing mark accessing screw	1	



Removing the cylinder head

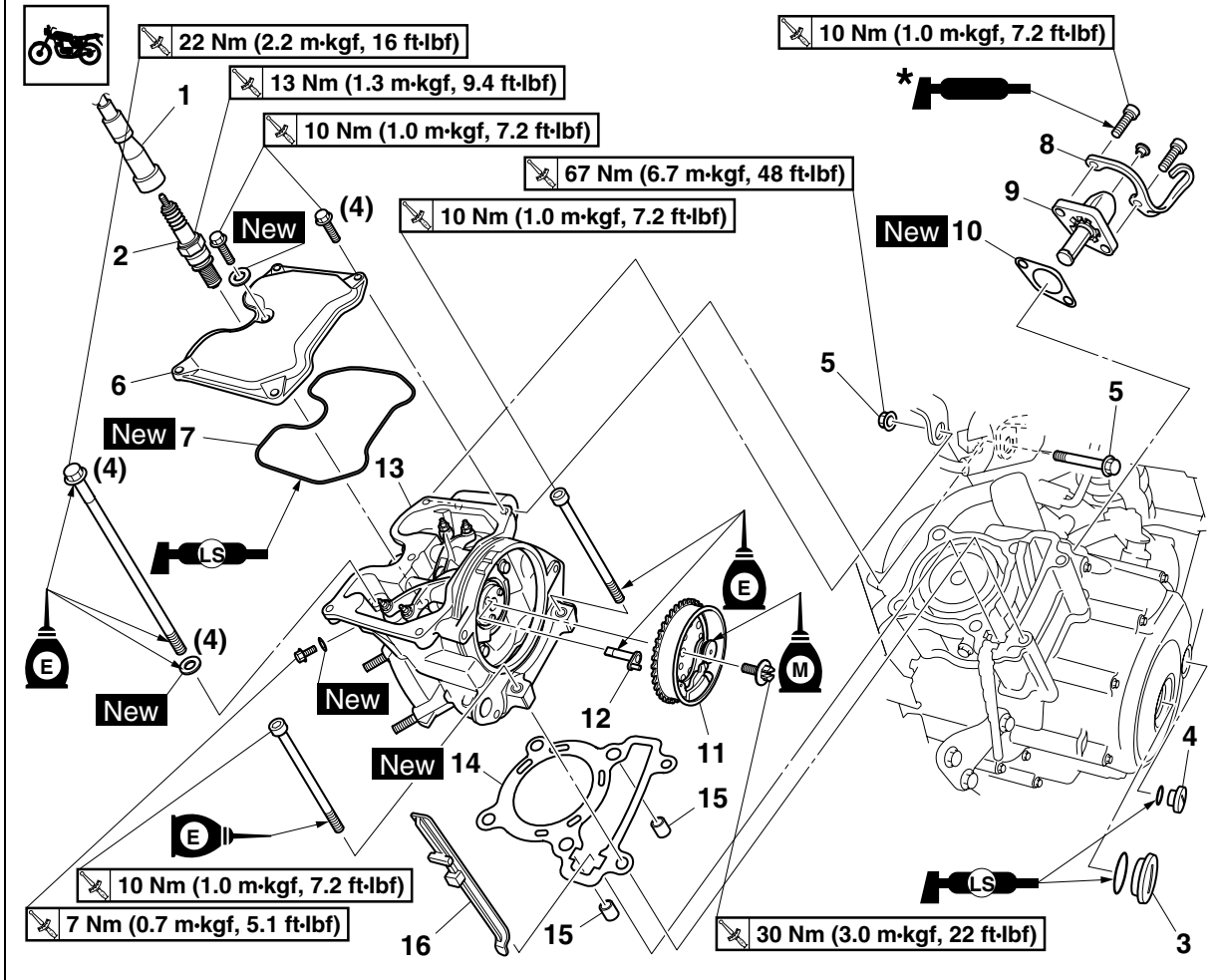

Order	Job/Parts to remove	Q'ty	Remarks
5	Engine front upper mounting bolt/nut	1/1	
6	Cylinder head cover	1	
7	Cylinder head cover gasket	1	
8	Clutch cable holder	1	
9	Timing chain tensioner	1	
10	Timing chain tensioner gasket	1	
11	Camshaft sprocket	1	
12	Decompression cam	1	
13	Cylinder head	1	
14	Cylinder head gasket	1	
15	Dowel pin	2	
16	Timing chain guide (exhaust side)	1	
			For installation, reverse the removal procedure.

\* Yamaha bond No. 1215 (Three Bond No.1215®)

EAS24130

## REMOVING THE CYLINDER HEAD

### 1. Align:

- "I" mark "a" on the generator rotor (with the stationary pointer "b" on the generator cover)



- Turn the crankshaft counterclockwise.
- When the piston is at TDC on the compression stroke, align the "I" mark "c" on the camshaft sprocket with the stationary pointer "d" on the cylinder head.

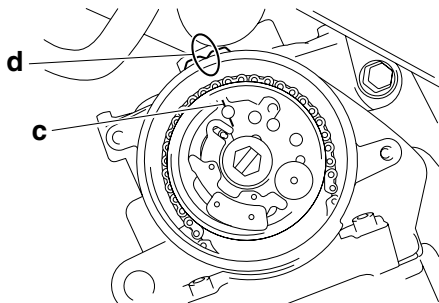
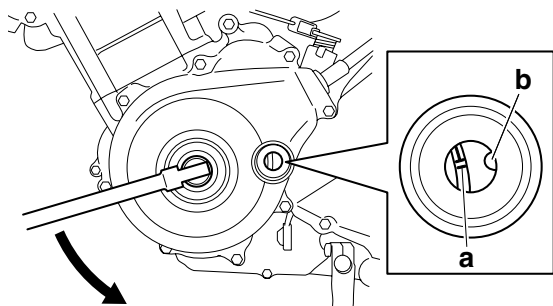

### 2. Loosen:

- Camshaft sprocket bolt "1"

### TIP

While holding the generator rotor nut with a wrench "2", loosen the camshaft sprocket bolt.

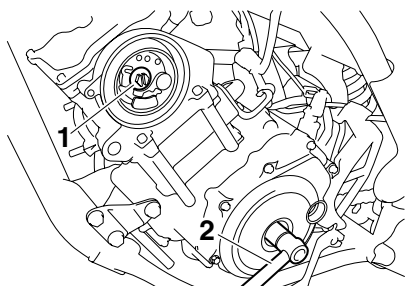

### 3. Remove:

- Camshaft sprocket

### TIP

To prevent the timing chain from falling into the crankcase, fasten it with a wire "1".

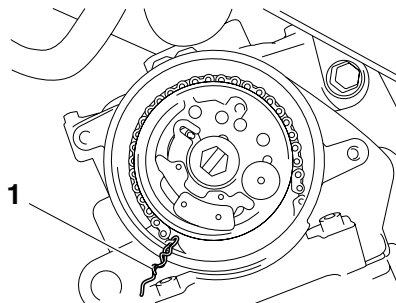

### 4. Remove:

- Cylinder head

### TIP

- Loosen the bolts in the proper sequence as shown.
- Loosen each bolt 1/2 of a turn at a time. After all of the bolts are fully loosened, remove them.
- Remove the cylinder head from the right side of the vehicle.

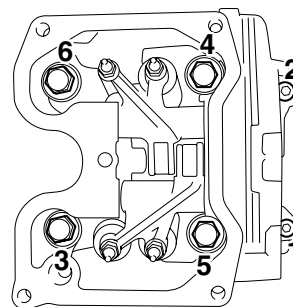

EAS24160

## CHECKING THE CYLINDER HEAD

### 1. Eliminate:

- Combustion chamber carbon deposits (with a rounded scraper)

### TIP

Do not use a sharp instrument to avoid damaging or scratching:

- Spark plug bore threads
- Valve seats

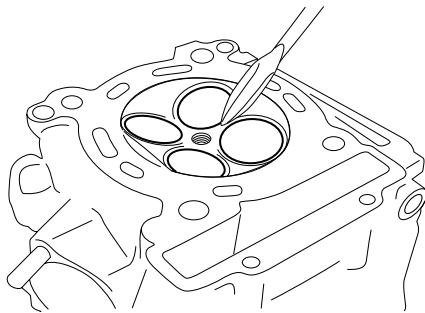

2. Check:
  - Cylinder head  
Damage/scratches → Replace.
  - Cylinder head water jacket  
Mineral deposits/rust → Eliminate.
3. Measure:
  - Cylinder head warpage  
Out of specification → Resurface the cylinder head.

	<p><b>Warpage limit</b> <b>0.03 mm (0.0012 in)</b></p>
--	--

- a. Place a straightedge "1" and a thickness gauge "2" across the cylinder head.

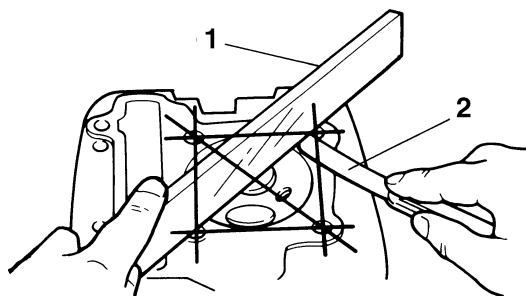

- b. Measure the warpage.
- c. If the limit is exceeded, resurface the cylinder head as follows.
- d. Place a 400–600 grit wet sandpaper on the surface plate and resurface the cylinder head using a figure-eight sanding pattern.

**TIP**

To ensure an even surface, rotate the cylinder head several times.

EAS22B1004

### CHECKING THE CAMSHAFT SPROCKET AND TIMING CHAIN GUIDE

1. Check:
  - Camshaft sprocket  
More than 1/4 tooth wear "a" → Replace the camshaft sprocket, timing chain and crankshaft as a set.

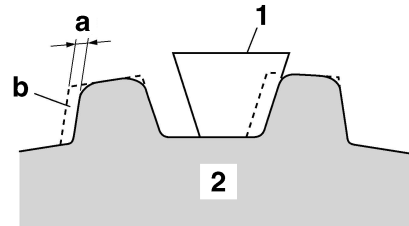

- a. 1/4 tooth
- b. Correct
1. Timing chain roller
2. Camshaft sprocket

2. Check:
  - Timing chain guide (exhaust side)  
Damage/wear → Replace.

EAS24200

### CHECKING THE TIMING CHAIN TENSIONER

1. Check:
  - Timing chain tensioner  
Cracks/damage/rough movement → Replace.

- a. Remove the timing chain tensioner cap.
- b. While lightly pressing the timing chain tensioner rod by hand, turn it clockwise with a thin screwdriver "1" until it stops.

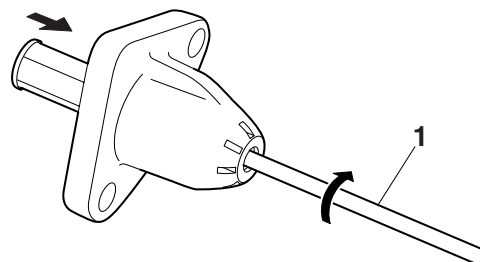

- c. Remove the screwdriver and slowly release the timing chain tensioner rod.

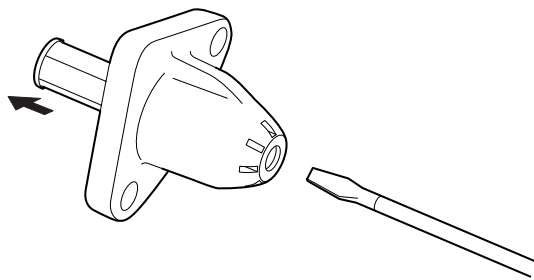

- d. Make sure that the timing chain tensioner rod comes out of the timing chain tensioner housing smoothly. If there is rough movement, replace the timing chain tensioner.
- e. Install the timing chain tensioner cap.



EAS22B1005

**CHECKING THE DECOMPRESSION SYSTEM**

1. Check:
    - Decompression system
- 
- a. Check the decompression system with the camshaft sprocket and the decompression cam installed to the camshaft.
  - b. Check that the decompression lever "1" moves smoothly.
  - c. Without operating the decompression lever, check that the decompression cam "2" projects from the camshaft (exhaust cam) as shown in the illustration "A".
  - d. Move the decompression lever "1" in the direction of the arrow shown and check that the decompression cam does not project from the camshaft (exhaust cam) as shown in the illustration "B".

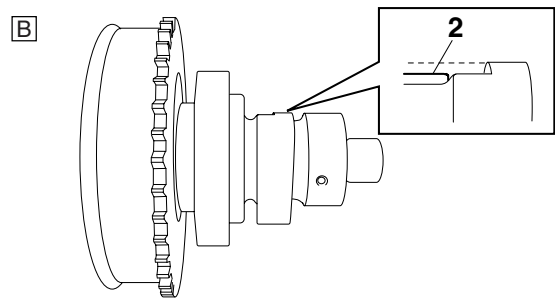
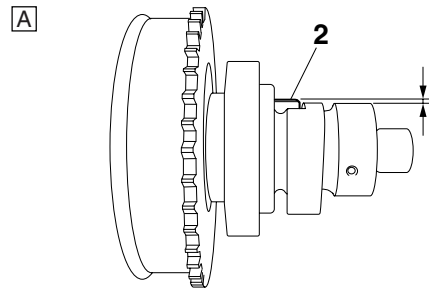
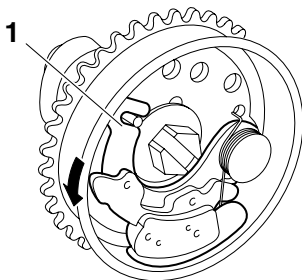

EAS24230

**INSTALLING THE CYLINDER HEAD**

1. Install:
    - Cylinder head
- TIP** \_\_\_\_\_
- Pass the timing chain through the timing chain cavity.
- 
2. Tighten:
    - Cylinder head bolts "1"

	<b>Cylinder head bolt</b> <b>22 Nm (2.2 m·kgf, 16 ft·lbf)</b>
--	--

- Cylinder head bolts "2"

	<b>Cylinder head bolt</b> <b>10 Nm (1.0 m·kgf, 7.2 ft·lbf)</b>
--	---

- TIP** \_\_\_\_\_
- Lubricate the cylinder head bolts and washers with engine oil.
  - Tighten the cylinder head bolts in the proper tightening sequence as shown and torque them in two stages.

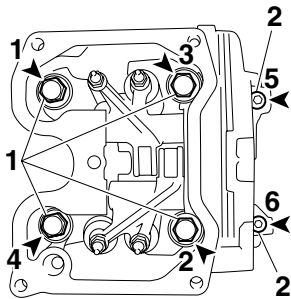

3. Install:
- Camshaft sprocket

- 
- Turn the crankshaft counterclockwise.
  - Align the “I” mark “a” on the generator rotor with the stationary pointer “b” on the generator cover.
  - Align the “I” mark “c” on the camshaft sprocket with the stationary pointer “d” on the cylinder head.
  - Install the timing chain onto the camshaft sprocket, and then install the camshaft sprocket onto the camshaft.

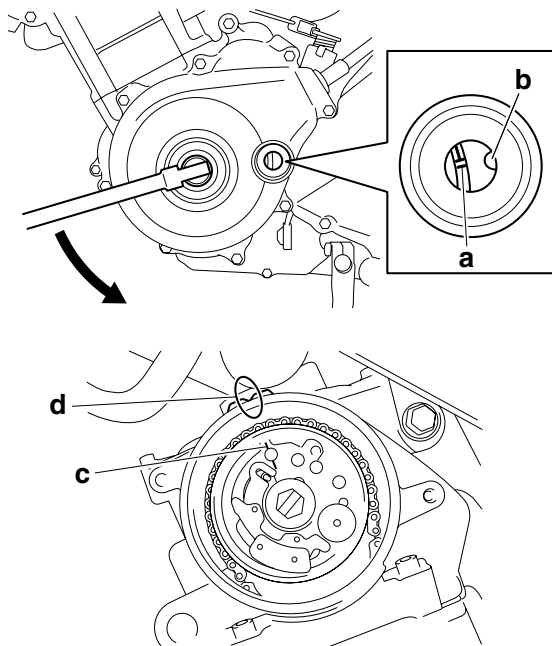

**TIP** \_\_\_\_\_  
 When installing the camshaft sprocket, be sure to keep the timing chain as tight as possible on the exhaust side.

ECA22B1009

**NOTICE**

**Do not turn the crankshaft when installing the camshaft to avoid damage or improper valve timing.**

- While holding the camshaft, temporarily tighten the camshaft sprocket bolt.
- Remove the wire from the timing chain.

4. Install:

- Timing chain tensioner gasket **New**
- Timing chain tensioner

- 
- Remove the timing chain tensioner cap.
  - While lightly pressing the timing chain tensioner rod by hand, turn it clockwise with a thin screwdriver “1” until it stops.
  - Install the gasket and the timing chain tensioner “2” onto the cylinder, and tighten the timing chain tensioner bolts “3” to specification.

**TIP** \_\_\_\_\_  
 Apply sealant to the timing chain tensioner bolt threads.

	<b>Yamaha bond No. 1215</b> <b>90890-85505</b> <b>(Three Bond No.1215®)</b>
	<b>Timing chain tensioner bolt</b> <b>10 Nm (1.0 m·kgf, 7.2 ft·lbf)</b>

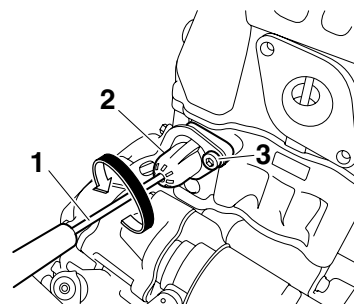
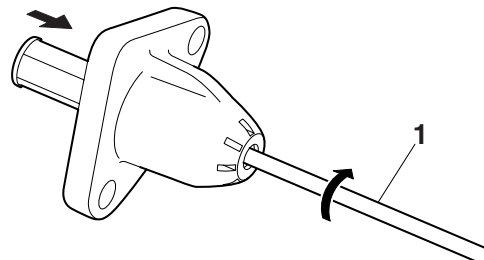

- Turn the timing chain tensioner rod counterclockwise with a thin screwdriver “1”, make sure the rod releases, and then install the timing chain tensioner cap.

## 5. Turn:

- Crankshaft  
(several turns counterclockwise)

## 6. Check:

- "I" mark "a"  
Align the "I" mark on the generator rotor with the stationary pointer "b" on the generator cover.
- "I" mark "c"  
Align the "I" mark on the camshaft sprocket with the stationary pointer "d" on the cylinder head.

Out of alignment → Correct.

Refer to the installation steps above.

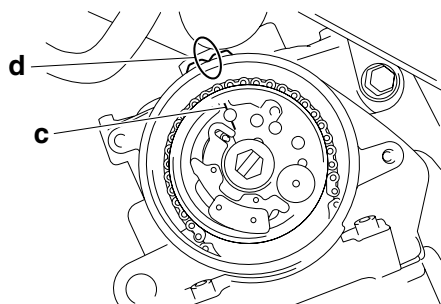
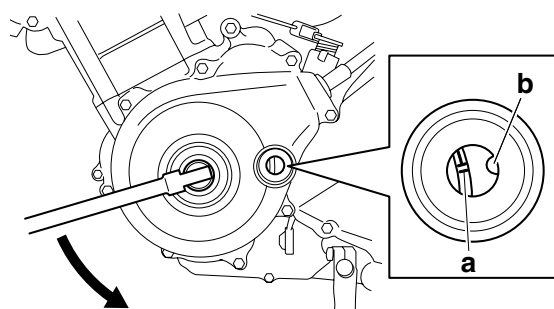

## 7. Tighten:

- Camshaft sprocket bolt



**Camshaft sprocket bolt**  
**30 Nm (3.0 m·kgf, 22 ft·lbf)**

ECA22B1010

**NOTICE**

**Be sure to tighten the camshaft sprocket bolt to the specified torque to avoid the possibility of the bolt coming loose and damaging the engine.**

## 8. Measure:

- Valve clearance  
Out of specification → Adjust.  
Refer to "ADJUSTING THE VALVE CLEARANCE" on page 3-4.

EAS23730

## CAMSHAFT

### Removing the rocker arms and camshaft

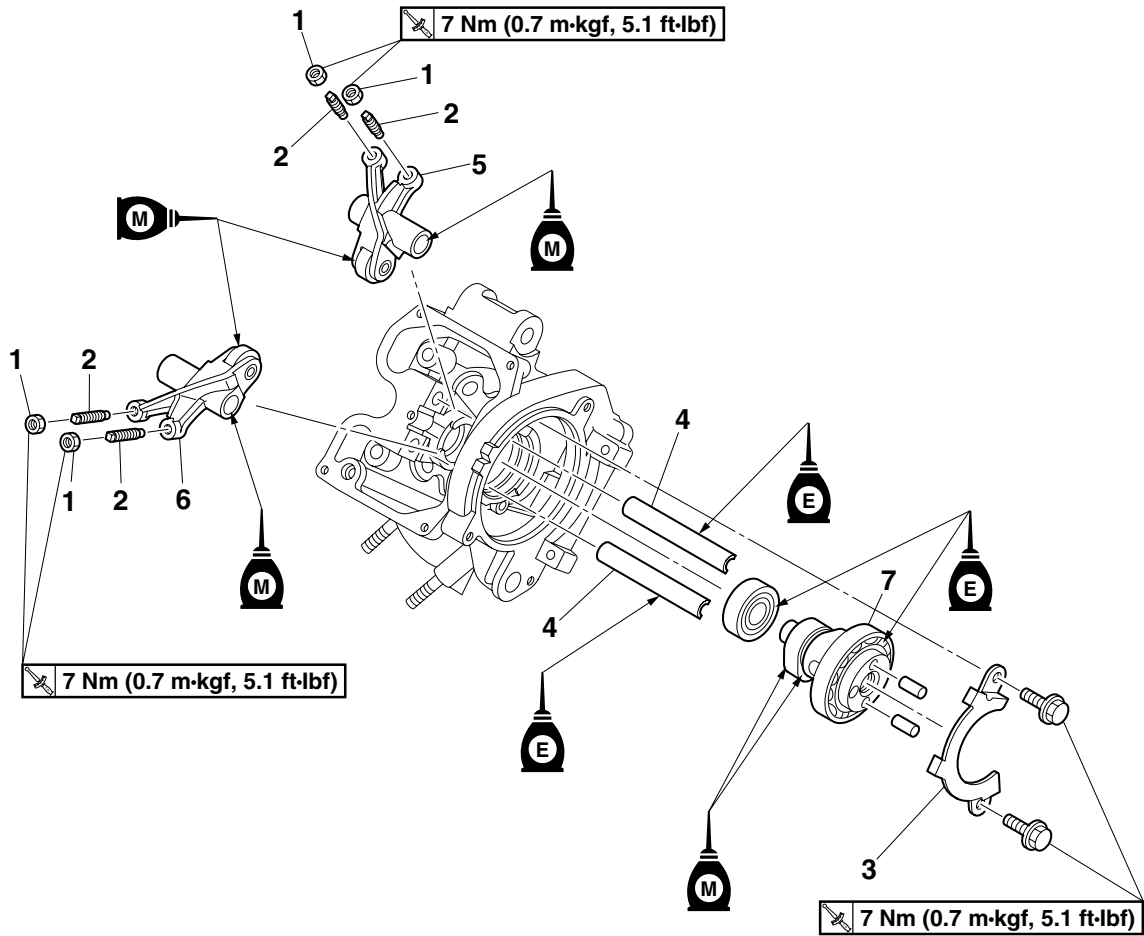

Order	Job/Parts to remove	Q'ty	Remarks
	Cylinder head		Refer to "CYLINDER HEAD" on page 5-7.
1	Locknut	4	
2	Adjusting screw	4	
3	Camshaft retainer	1	
4	Rocker arm shaft	2	
5	Intake rocker arm	1	
6	Exhaust rocker arm	1	
7	Camshaft	1	
			For installation, reverse the removal procedure.

EAS23840

## CHECKING THE CAMSHAFT

1. Check:
  - Camshaft lobes  
Blue discoloration/pitting/scratches → Replace the camshaft.
2. Measure:
  - Camshaft lobe dimensions “a” and “b”  
Out of specification → Replace the camshaft.



**Camshaft lobe dimensions**

**Intake A**  
30.225–30.325 mm (1.1900–1.1939 in)  
**Limit**  
30.125 mm (1.1860 in)

**Intake B**  
25.127–25.227 mm (0.9893–0.9932 in)  
**Limit**  
25.027 mm (0.9853 in)

**Exhaust A**  
30.232–30.332 mm (1.1902–1.1942 in)  
**Limit**  
30.132 mm (1.1863 in)

**Exhaust B**  
25.065–25.165 mm (0.9868–0.9907 in)  
**Limit**  
24.965 mm (0.9829 in)

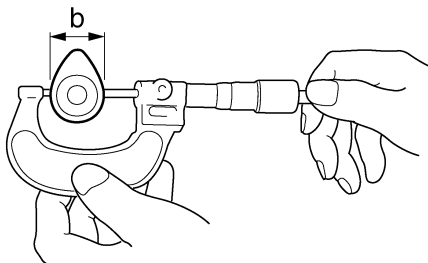
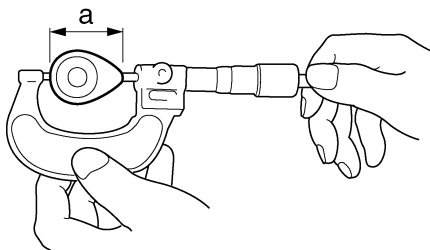

3. Check:
  - Camshaft oil passage  
Obstruction → Blow out with compressed air.

EAS23880

## CHECKING THE ROCKER ARMS AND ROCKER ARM SHAFTS

The following procedure applies to all of the rocker arms and rocker arm shafts.

1. Check:
  - Rocker arm  
Damage/wear → Replace.
2. Check:
  - Rocker arm shaft  
Blue discoloration/excessive wear/pitting/scratches → Replace or check the lubrication system.
3. Measure:
  - Rocker arm inside diameter “a”  
Out of specification → Replace.



**Rocker arm inside diameter**  
9.985–10.000 mm (0.3931–0.3937 in)  
**Limit**  
10.015 mm (0.3943 in)

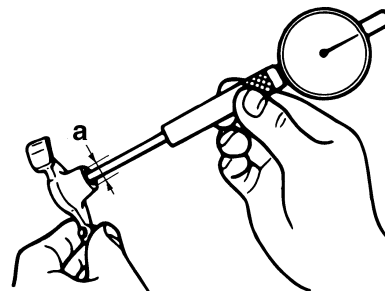

4. Measure:
  - Rocker arm shaft outside diameter “a”  
Out of specification → Replace.



**Rocker arm shaft outside diameter**  
9.966–9.976 mm (0.3924–0.3928 in)  
**Limit**  
9.941 mm (0.3914 in)

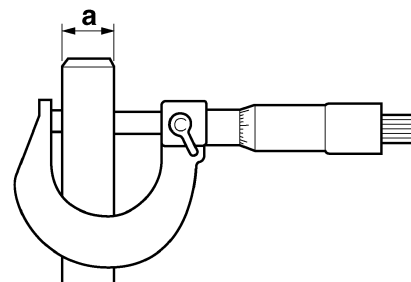



5. Calculate:

- Rocker-arm-to-rocker-arm-shaft clearance

**TIP** \_\_\_\_\_

Calculate the clearance by subtracting the rocker arm shaft outside diameter from the rocker arm inside diameter.

Out of specification → Replace the defective part(s).

	<p><b>Rocker-arm-to-rocker-arm-shaft clearance</b>  <b>0.009–0.034 mm (0.0004–0.0013 in)</b>  <b>Limit</b>  <b>0.074 mm (0.0029 in)</b></p>
---	---

EAS24040

### INSTALLING THE CAMSHAFT AND ROCKER ARMS

1. Lubricate:

- Rocker arms
- Rocker arm shafts

	<p><b>Recommended lubricant</b>  <b>Rocker arm inner surface</b>  <b>Molybdenum disulfide oil</b>  <b>Rocker arm shaft</b>  <b>Engine oil</b></p>
--	---

2. Lubricate:

- Camshaft

	<p><b>Recommended lubricant</b>  <b>Camshaft</b>  <b>Molybdenum disulfide oil</b>  <b>Camshaft bearing</b>  <b>Engine oil</b></p>
---	---

3. Install:

- Camshaft “1”

**TIP** \_\_\_\_\_

Make sure that the camshaft projections “a” and hole “b” are positioned as shown in the illustration.

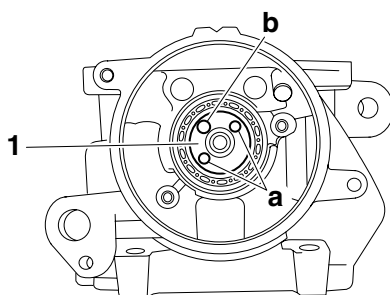

4. Install:

- Rocker arms
- Rocker arm shafts “1”

**TIP** \_\_\_\_\_

- Make sure that the cutout “a” in each rocker arm shaft is facing downward as shown in the illustration.
- Make sure the rocker arm shafts (intake and exhaust) are completely pushed into the cylinder head.

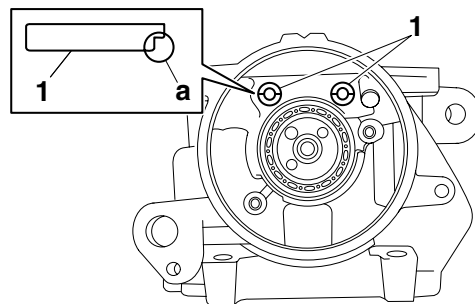

EAS24270

**VALVES AND VALVE SPRINGS**

**Removing the valves and valve springs**

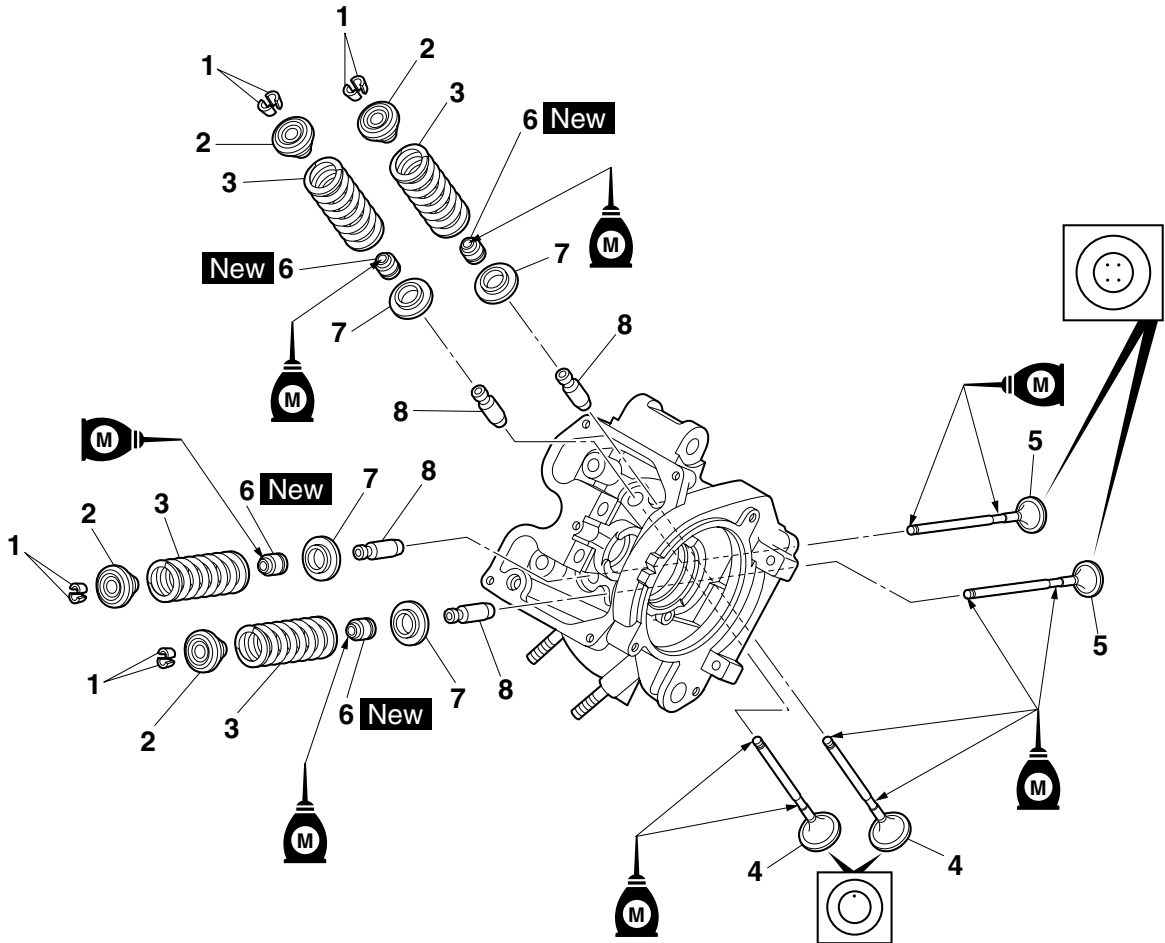

Order	Job/Parts to remove	Q'ty	Remarks
	Cylinder head		Refer to "CYLINDER HEAD" on page 5-7.
	Rocker arms/Camshaft		Refer to "CAMSHAFT" on page 5-14.
1	Valve cotter	8	
2	Upper spring seat	4	
3	Valve spring	4	
4	Intake valve	2	
5	Exhaust valve	2	
6	Valve stem seal	4	
7	Lower spring seat	4	
8	Valve guide	4	
			For installation, reverse the removal procedure.

EAS24280

## REMOVING THE VALVES

The following procedure applies to all of the valves and related components.

**TIP** \_\_\_\_\_

Before removing the internal parts of the cylinder head (e.g., valves, valve springs, valve seats), make sure the valves properly seal.

1. Check:

- Valve sealing

Leakage at the valve seat → Check the valve face, valve seat, and valve seat width.

Refer to “CHECKING THE VALVE SEATS” on page 5-20.



a. Pour a clean solvent “a” into the intake and exhaust ports.

b. Check that the valves properly seal.

**TIP** \_\_\_\_\_

There should be no leakage at the valve seat “1”.

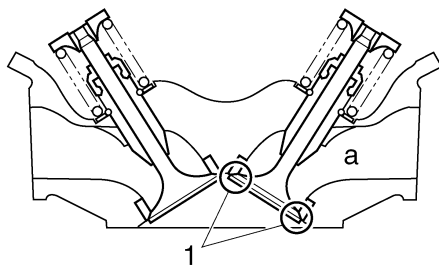

2. Remove:

- Valve cotters “1”

**TIP** \_\_\_\_\_

Remove the valve cotters by compressing the valve spring with the valve spring compressor and the valve spring compressor attachment.



- Valve spring compressor**  
90890-04019  
YM-04019
- Valve spring compressor attachment**  
90890-04108
- Valve spring compressor adapter 22 mm**  
YM-04108

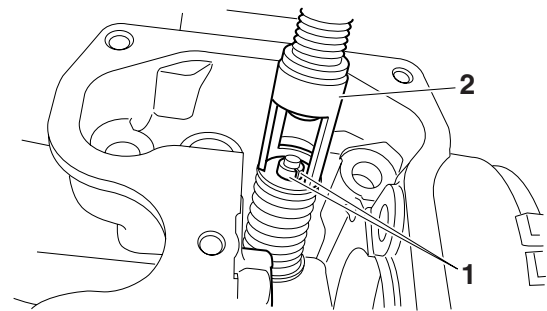

3. Remove:

- Upper spring seat “1”
- Valve spring “2”
- Valve “3”
- Valve stem seal “4”
- Lower spring seat “5”

**TIP** \_\_\_\_\_

Identify the position of each part very carefully so that it can be reinstalled in its original place.

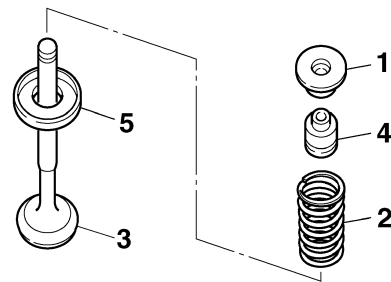

EAS24290

## CHECKING THE VALVES AND VALVE GUIDES

The following procedure applies to all of the valves and valve guides.

1. Measure:

- Valve-stem-to-valve-guide clearance  
Out of specification → Replace the valve guide.

<ul style="list-style-type: none"> <li>• Valve-stem-to-valve-guide clearance = Valve guide inside diameter “a” - Valve stem diameter “b”</li> </ul>
---



**Valve-stem-to-valve-guide clearance (intake)**  
 0.010–0.037 mm (0.0004–0.0015 in)  
**Limit**  
 0.080 mm (0.0032 in)  
**Valve-stem-to-valve-guide clearance (exhaust)**  
 0.025–0.052 mm (0.0010–0.0020 in)  
**Limit**  
 0.100 mm (0.0039 in)

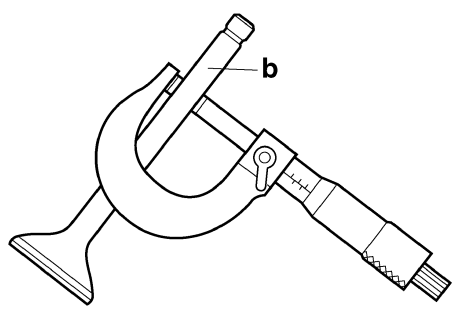
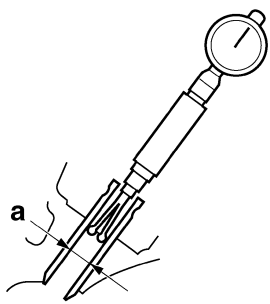

2. Replace:  
 • Valve guide

**TIP**  
 To ease valve guide removal and installation, and to maintain the correct fit, heat the cylinder head to 100 °C (212 °F) in an oven.

a. Remove the valve guide with the valve guide remover "1".

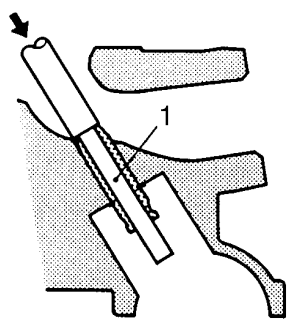

b. Install the new valve guide with the valve guide installer "2" and valve guide remover "1".



**Valve guide position (intake)**  
 17.0–17.4 mm (0.669–0.685 in)  
**Valve guide position (exhaust)**  
 14.0–14.4 mm (0.551–0.567 in)

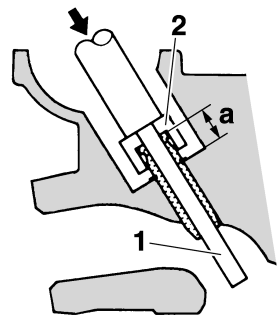

a. Valve guide position

c. After installing the valve guide, bore the valve guide with the valve guide reamer "3" to obtain the proper valve-stem-to-valve-guide clearance.

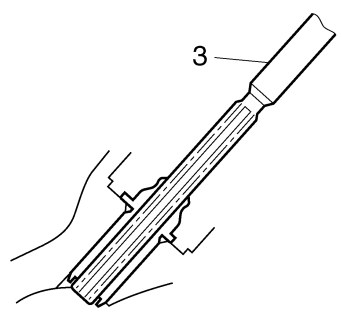

**TIP**  
 After replacing the valve guide, reface the valve seat.



**Valve guide remover (ø4.5)**  
 90890-04116  
**Valve guide remover (4.5 mm)**  
 YM-04116  
**Valve guide installer (ø4.5)**  
 90890-04117  
**Valve guide installer (4.5 mm)**  
 YM-04117  
**Valve guide reamer (ø4.5)**  
 90890-04118  
**Valve guide reamer (4.5 mm)**  
 YM-04118

3. Eliminate:
  - Carbon deposits  
(from the valve face and valve seat)
4. Check:
  - Valve face  
Pitting/wear → Grind the valve face.
  - Valve stem end  
Mushroom shape or diameter larger than the body of the valve stem → Replace the valve.
5. Measure:
  - Valve margin thickness D “a”  
Out of specification → Replace the valve.



**Valve margin thickness D (intake)**  
0.50–0.90 mm (0.0197–0.0354 in)  
**Valve margin thickness D (exhaust)**  
0.50–0.90 mm (0.0197–0.0354 in)

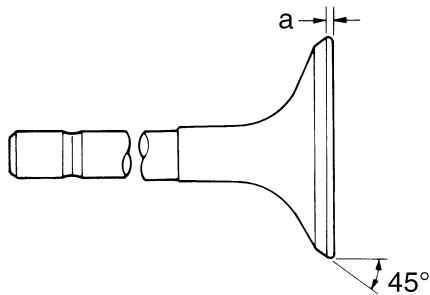

6. Measure:
  - Valve stem runout  
Out of specification → Replace the valve.

**TIP**

- When installing a new valve, always replace the valve guide.
- If the valve is removed or replaced, always replace the valve stem seal.



**Valve stem runout**  
0.010 mm (0.0004 in)

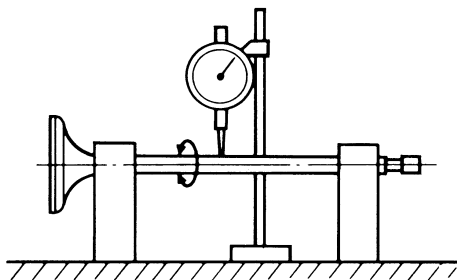

EAS24300

**CHECKING THE VALVE SEATS**

The following procedure applies to all of the valves and valve seats.

1. Eliminate:
  - Carbon deposits  
(from the valve face and valve seat)
2. Check:
  - Valve seat  
Pitting/wear → Replace the cylinder head.
3. Measure:
  - Valve seat width C “a”  
Out of specification → Replace the cylinder head.



**Valve seat width C (intake)**  
0.90–1.10 mm (0.0354–0.0433 in)  
**Valve seat width C (exhaust)**  
0.90–1.10 mm (0.0354–0.0433 in)

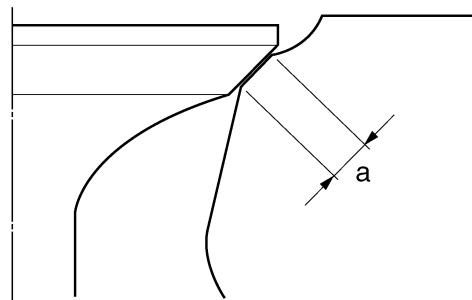

- a. Apply Mechanic’s blueing dye (Dykem) “b” onto the valve face.

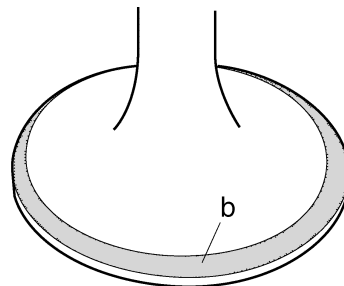

- b. Install the valve into the cylinder head.
- c. Press the valve through the valve guide and onto the valve seat to make a clear impression.
- d. Measure the valve seat width.

**TIP**

Where the valve seat and valve face contacted one another, the blueing will have been removed.





**Free length (intake)**  
41.71 mm (1.64 in)  
**Limit**  
39.62 mm (1.56 in)  
**Free length (exhaust)**  
41.71 mm (1.64 in)  
**Limit**  
39.62 mm (1.56 in)

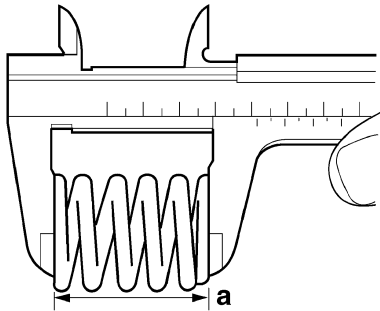

2. Measure:
- Compressed valve spring force "a"  
Out of specification → Replace the valve spring.



**Installed compression spring force (intake)**  
140.00–162.00 N (14.28–16.52 kgf, 31.47–36.42 lbf)  
**Installed compression spring force (exhaust)**  
140.00–162.00 N (14.28–16.52 kgf, 31.47–36.42 lbf)  
**Installed length (intake)**  
35.30 mm (1.39 in)  
**Installed length (exhaust)**  
35.30 mm (1.39 in)

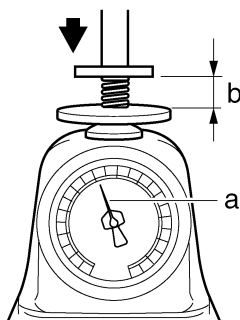

b. Installed length

3. Measure:
- Valve spring tilt "a"  
Out of specification → Replace the valve spring.



**Spring tilt (intake)**  
2.5°/1.8 mm  
**Spring tilt (exhaust)**  
2.5°/1.8 mm

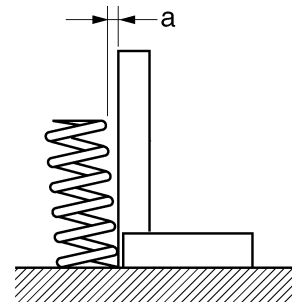

EAS24340

**INSTALLING THE VALVES**

The following procedure applies to all of the valves and related components.

1. Deburr:
- Valve stem end  
(with an oil stone)

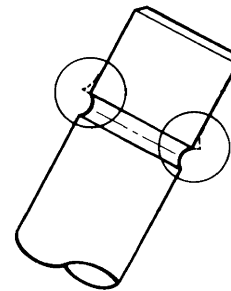

2. Lubricate:
- Valve stem "1"
  - Valve stem seal "2" **New**  
(with the recommended lubricant)



**Recommended lubricant**  
Molybdenum disulfide oil

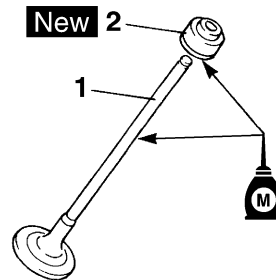

3. Install:
- Lower spring seat "1"
  - Valve stem seal "2" **New**

- Valve "3"
- Valve spring "4"
- Upper spring seat "5"  
(into the cylinder head)

**TIP**

- Make sure each valve is installed in its original place.
- Install the valve springs with the larger pitch "a" facing up.

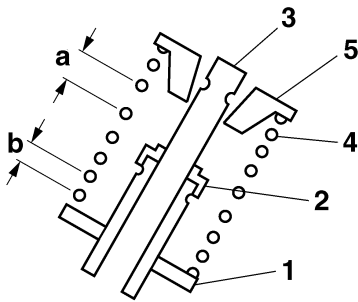
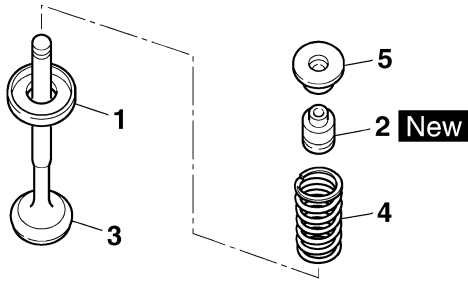

b. Smaller pitch

**4. Install:**

- Valve cotters "1"

**TIP**

Install the valve cotters by compressing the valve spring with the valve spring compressor and the valve spring compressor attachment "2".



**Valve spring compressor**  
90890-04019  
YM-04019  
**Valve spring compressor attachment**  
90890-04108  
**Valve spring compressor adapter 22 mm**  
YM-04108

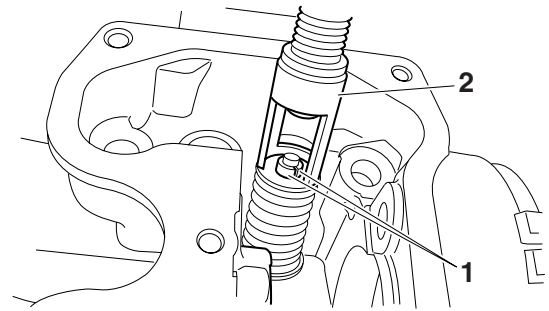

5. To secure the valve cotters onto the valve stem, lightly tap the valve tip with a soft-face hammer.

ECA13800

**NOTICE**

Hitting the valve tip with excessive force could damage the valve.

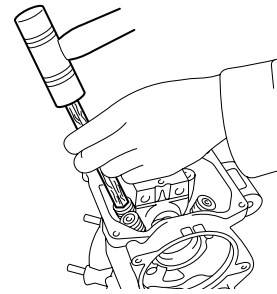



EAS24350

**CYLINDER AND PISTON**

**Removing the cylinder and piston**

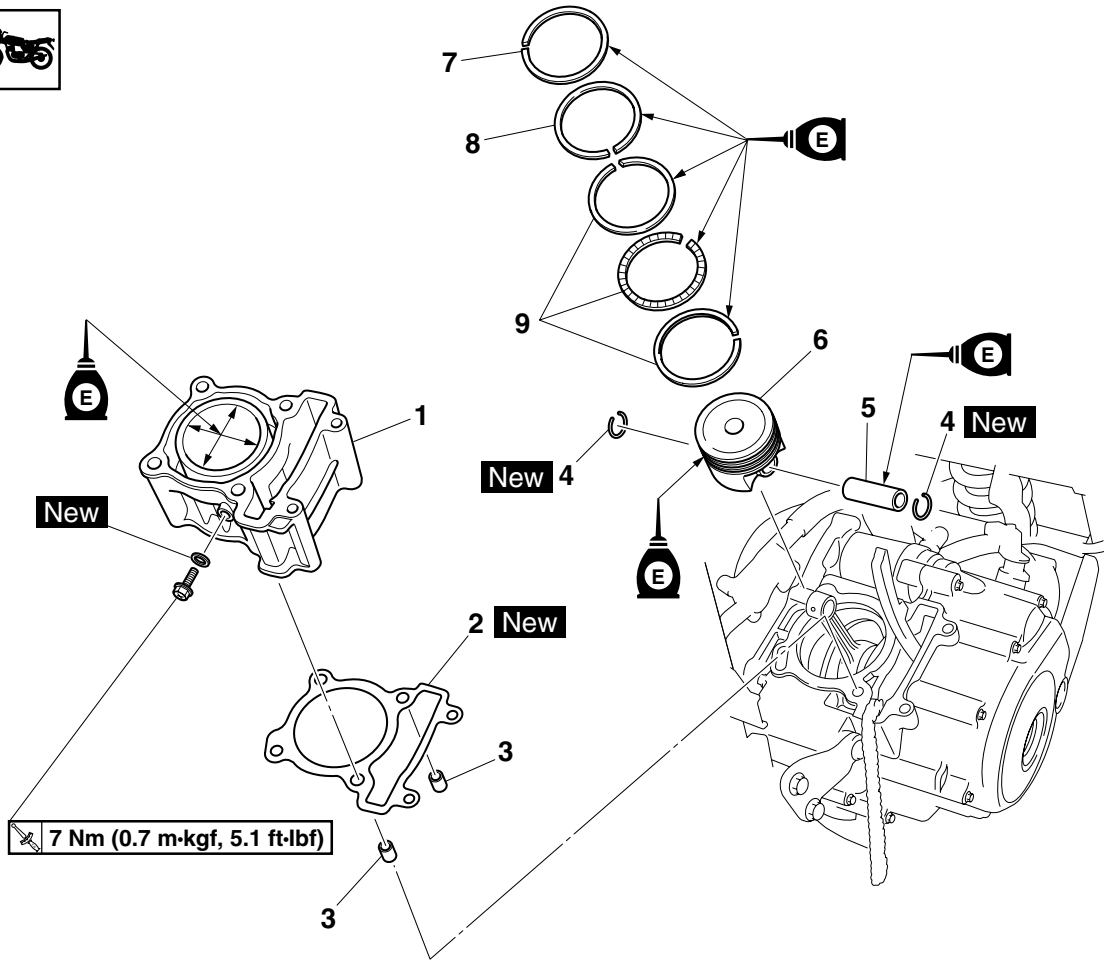

Order	Job/Parts to remove	Q'ty	Remarks
	Cylinder head		Refer to "CYLINDER HEAD" on page 5-7.
1	Cylinder	1	
2	Cylinder gasket	1	
3	Dowel pin	2	
4	Piston pin clip	2	
5	Piston pin	1	
6	Piston	1	
7	Top ring	1	
8	2nd ring	1	
9	Oil ring	1	
			For installation, reverse the removal procedure.

EAS24380

## REMOVING THE PISTON

### 1. Remove:

- Piston pin clips “1”
- Piston pin “2”
- Piston “3”

ECA13810

### NOTICE

**Do not use a hammer to drive the piston pin out.**

### TIP

- Before removing the piston pin clips, cover the crankcase opening with a clean rag to prevent the piston pin clips from falling into the crankcase.
- Before removing the piston pin, deburr the piston pin clip grooves and the piston pin bore area. If both areas are deburred and the piston pin is still difficult to remove, remove it with the piston pin puller set “4”.

	<p><b>Piston pin puller set 90890-01304</b></p> <p><b>Piston pin puller YU-01304</b></p>
--	--

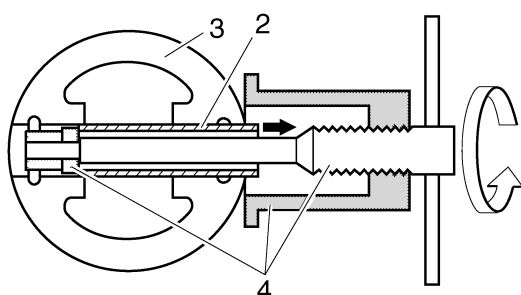
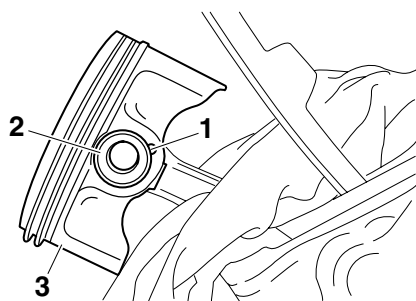

### 2. Remove:

- Top ring
- 2nd ring
- Oil ring

### TIP

When removing a piston ring, open the end gap with your fingers and lift the other side of the ring over the piston crown.

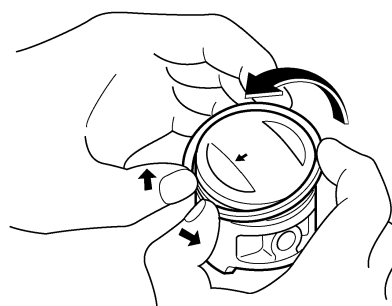

EAS24390

## CHECKING THE CYLINDER AND PISTON

### 1. Check:

- Piston wall
- Cylinder wall  
Vertical scratches → Replace the cylinder, and replace the piston and piston rings as a set.

### 2. Measure:

- Piston-to-cylinder clearance

- Measure cylinder bore “C” with the cylinder bore gauge.

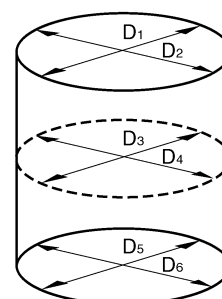

### TIP

Measure cylinder bore “C” by taking side-to-side and front-to-back measurements of the cylinder. Then, find the average of the measurements.



**Bore**  
52.000–52.010 mm (2.0472–2.0476 in)  
**Taper limit**  
0.050 mm (0.0020 in)  
**Out of round limit**  
0.005 mm (0.0002 in)

"C" = maximum of D <sub>1</sub> -D <sub>2</sub>
"T" = maximum of D <sub>1</sub> or D <sub>2</sub> - maximum of D <sub>5</sub> or D <sub>6</sub>
"R" = maximum of D <sub>1</sub> , D <sub>3</sub> or D <sub>5</sub> - minimum of D <sub>2</sub> , D <sub>4</sub> or D <sub>6</sub>

- b. If out of specification, replace the cylinder, and replace the piston and piston rings as a set.
- c. Measure piston skirt diameter D "a" with the micrometer.

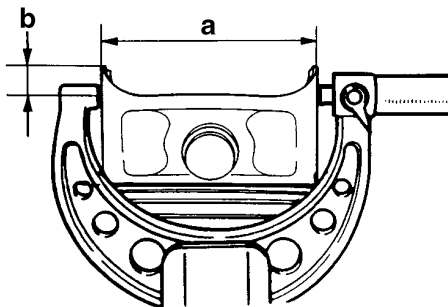

b. 5.0 mm (0.20 in) from the bottom edge of the piston

**Piston Diameter D**  
51.962–51.985 mm (2.0457–2.0466 in)

- d. If out of specification, replace the piston and piston rings as a set.
- e. Calculate the piston-to-cylinder clearance with the following formula.

- Piston-to-cylinder clearance =  
Cylinder bore "C" -  
Piston skirt diameter "D"

**Piston-to-cylinder clearance**  
0.015–0.048 mm (0.0006–0.0019 in)  
**Limit**  
0.15 mm (0.0059 in)

- f. If out of specification, replace the cylinder, and replace the piston and piston rings as a set.



EAS24430

## CHECKING THE PISTON RINGS

1. Measure:
  - Piston ring side clearance  
Out of specification → Replace the piston and piston rings as a set.

### TIP

Before measuring the piston ring side clearance, eliminate any carbon deposits from the piston ring grooves and piston rings.

**Piston ring**  
**Top ring**  
**Ring side clearance**  
0.030–0.065 mm (0.0012–0.0026 in)  
**Limit**  
0.100 mm (0.0039 in)  
**2nd ring**  
**Ring side clearance**  
0.020–0.055 mm (0.0008–0.0022 in)  
**Limit**  
0.100 mm (0.0039 in)

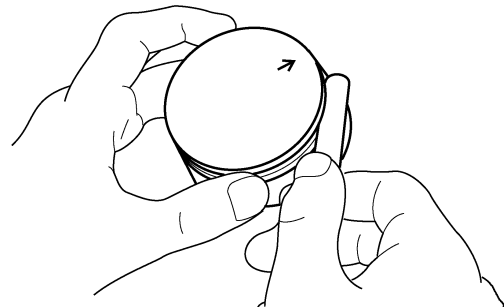

2. Install:
  - Piston ring  
(into the cylinder)

### TIP

Level the piston ring into the cylinder with the piston crown.

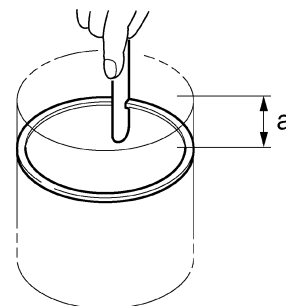

a. 40 mm (1.57 in)

### 3. Measure:

- Piston ring end gap  
Out of specification → Replace the piston ring.

#### TIP

The oil ring expander end gap cannot be measured. If the oil ring rail gap is excessive, replace all three piston rings.



**Piston ring**  
**Top ring**  
**End gap (installed)**  
 0.10–0.25 mm (0.0039–0.0098 in)  
**Limit**  
 0.50 mm (0.0197 in)  
**2nd ring**  
**End gap (installed)**  
 0.10–0.25 mm (0.0039–0.0098 in)  
**Limit**  
 0.60 mm (0.0236 in)  
**Oil ring**  
**End gap (installed)**  
 0.20–0.70 mm (0.0079–0.0276 in)

EAS24440

### CHECKING THE PISTON PIN

#### 1. Check:

- Piston pin  
Blue discoloration/grooves → Replace the piston pin, and then check the lubrication system.

#### 2. Measure:

- Piston pin outside diameter “a”  
Out of specification → Replace the piston pin.



**Piston pin outside diameter**  
 13.995–14.000 mm (0.5510–0.5512 in)  
**Limit**  
 13.975 mm (0.5502 in)

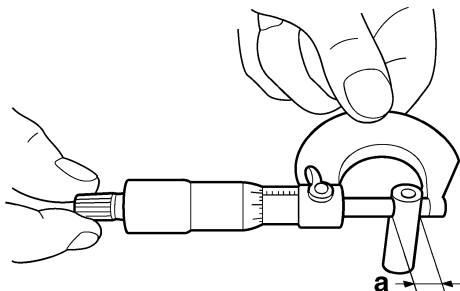

### 3. Measure:

- Piston pin bore inside diameter “b”  
Out of specification → Replace the piston.



**Piston pin bore inside diameter**  
 14.002–14.013 mm (0.5513–0.5517 in)  
**Limit**  
 14.043 mm (0.5529 in)

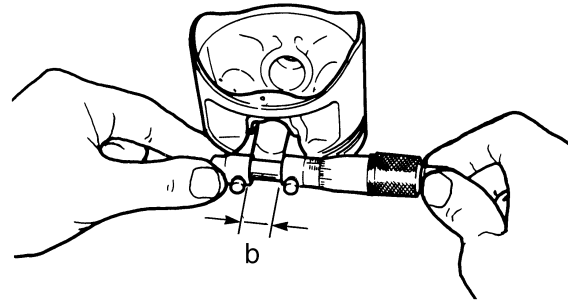

### 4. Calculate:

- Piston-pin-to-piston-pin-bore clearance  
Out of specification → Replace the piston pin and piston as a set.

• Piston-pin-to-piston-pin-bore clearance =  
 Piston pin bore inside diameter “b” -  
 Piston pin outside diameter “a”



**Piston-pin-to-piston-pin-bore clearance**  
 0.002–0.018 mm (0.0001–0.0007 in)  
**Limit**  
 0.068 mm (0.0027 in)

EAS24450

### INSTALLING THE PISTON AND CYLINDER

#### 1. Install:

- Top ring “1”
- 2nd ring “2”
- Oil ring expander “3”
- Lower oil ring rail “4”
- Upper oil ring rail “5”

#### TIP

Be sure to install the piston rings so that the manufacturer marks or numbers face up.

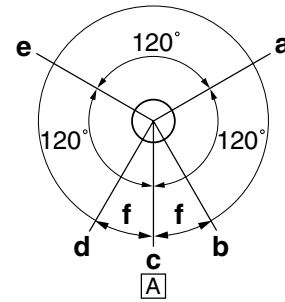
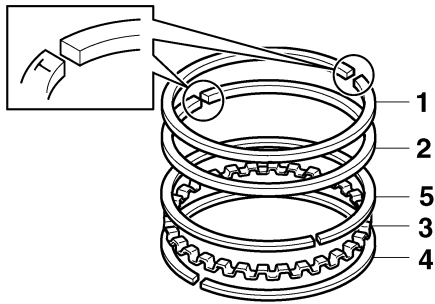

## 2. Install:

- Piston "1"
- Piston pin "2"
- Piston pin clips "3" **New**

### TIP

- Apply engine oil to the piston pin.
- Make sure the punch mark "a" on the piston points towards the exhaust side of the cylinder.
- Before installing the piston pin clips, cover the crankcase opening with a clean rag to prevent the clips from falling into the crankcase.

- a. Top ring
- b. Upper oil ring rail
- c. Oil ring expander
- d. Lower oil ring rail
- e. 2nd ring
- f. 20 mm (0.79 in)
- A. Intake side

## 5. Install:

- Dowel pins
- Cylinder gasket **New**
- Cylinder "1"

### TIP

- While compressing the piston rings with one hand, install the cylinder with the other hand.
- Pass the timing chain and timing chain guide (intake side) through the timing chain cavity.

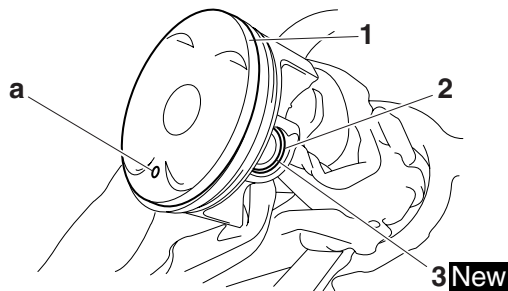

## 3. Lubricate:

- Piston
- Piston rings
- Cylinder  
(with the recommended lubricant)



## 4. Offset:

- Piston ring end gaps

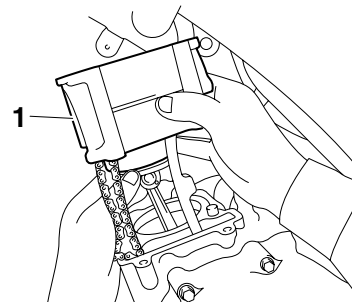

# YamahaR125.COM GENERATOR AND STARTER CLUTCH

EAS22B1006

## GENERATOR AND STARTER CLUTCH

### Removing the generator and starter clutch

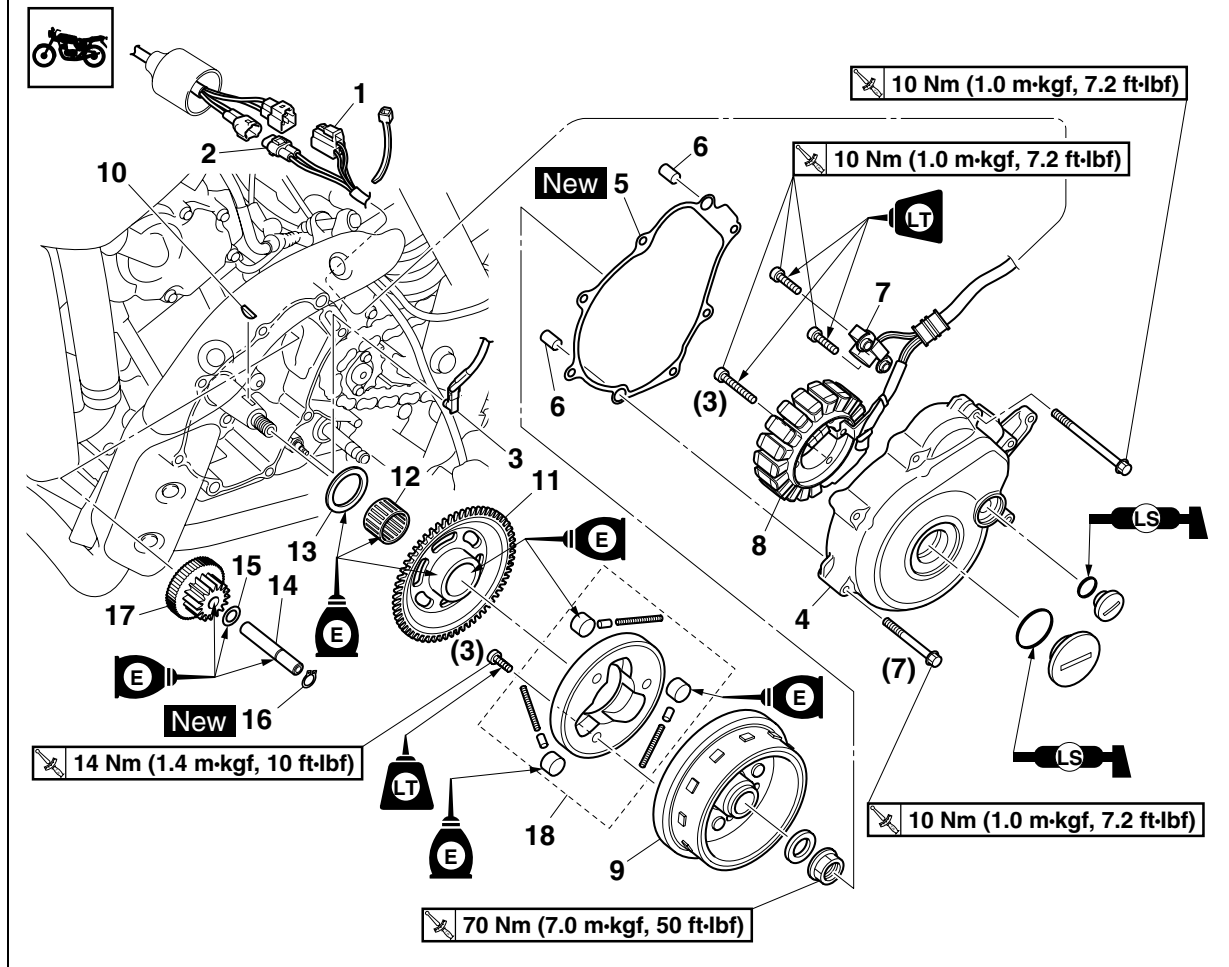

Order	Job/Parts to remove	Q'ty	Remarks
	Engine oil		Drain. Refer to "CHANGING THE ENGINE OIL" on page 3-10.
	Drive sprocket cover		Refer to "CHAIN DRIVE" on page 4-67.
	Shift pedal		Refer to "ENGINE REMOVAL" on page 5-1.
1	Stator coil coupler	1	Disconnect.
2	Crankshaft position sensor coupler	1	Disconnect.
3	Neutral switch lead connector	1	Disconnect.
4	Generator cover	1	
5	Generator cover gasket	1	
6	Dowel pin	2	
7	Crankshaft position sensor	1	
8	Stator coil	1	
9	Generator rotor	1	
10	Woodruff key	1	
11	Starter clutch gear	1	
12	Bearing	1	

# YamahaR125.COM GENERATOR AND STARTER CLUTCH

## Removing the generator and starter clutch

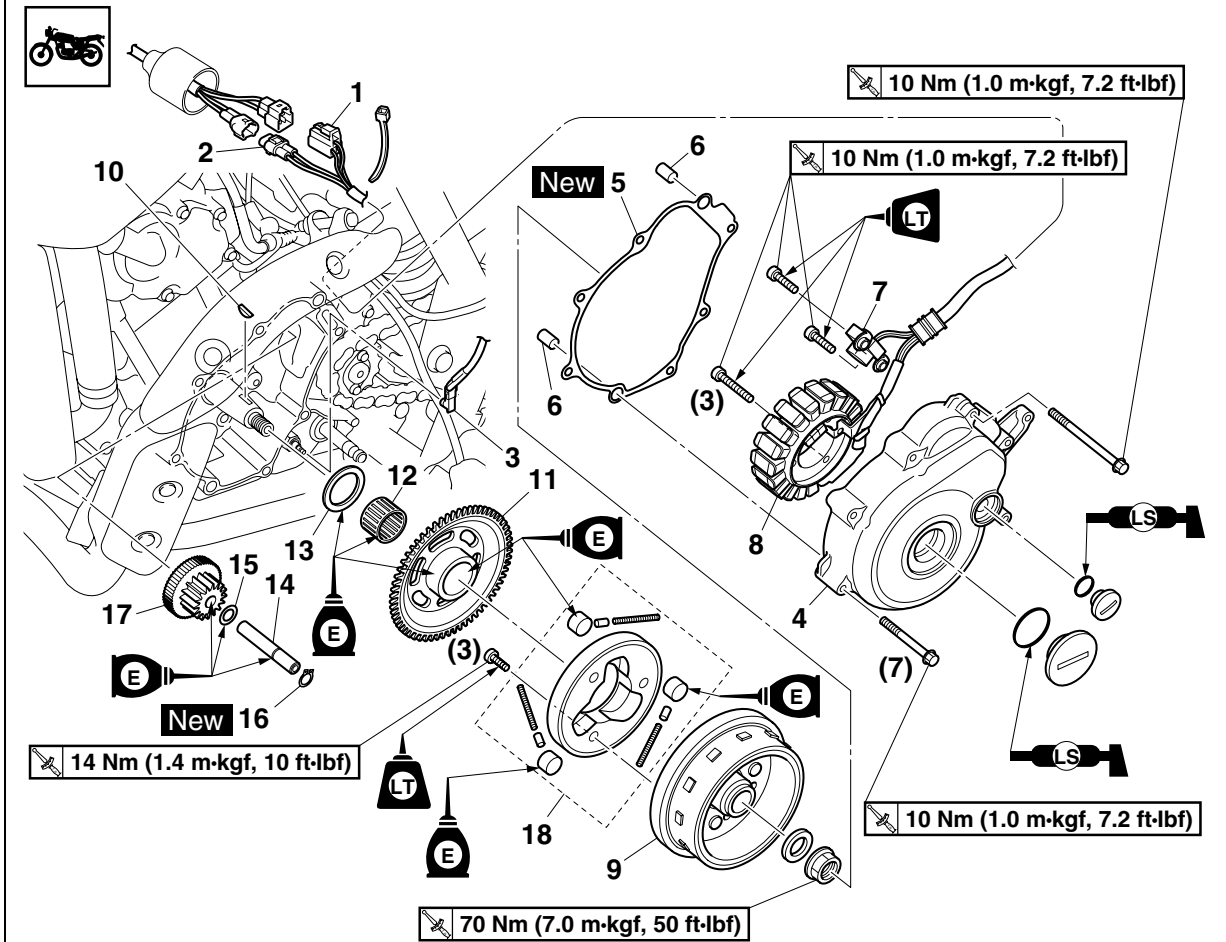

Order	Job/Parts to remove	Q'ty	Remarks
13	Washer	1	
14	Starter clutch idle gear shaft	1	
15	Washer	1	
16	Circlip	1	
17	Starter clutch idle gear	1	
18	Starter clutch assembly	1	
			For installation, reverse the removal procedure.

# YamahaR125.COM GENERATOR AND STARTER CLUTCH

EAS24490

## REMOVING THE GENERATOR

1. Remove:
  - Generator cover

### TIP

Loosen each bolt 1/4 of a turn at a time, in stages and in a crisscross pattern. After all of the bolts are fully loosened, remove them.

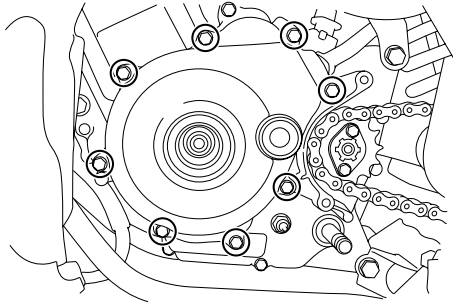

2. Remove:
  - Generator rotor nut "1"
  - Washer

### TIP

- While holding the generator rotor "2" with the sheave holder "3", loosen the generator rotor nut.
- Do not allow the sheave holder to touch the projections on the generator rotor.



**Sheave holder**  
90890-01701  
**Primary clutch holder**  
YS-01880-A

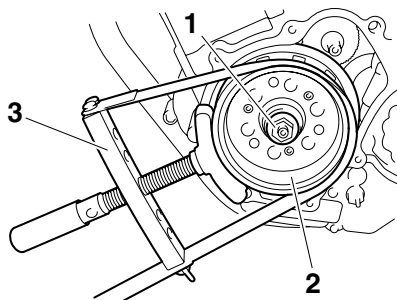

3. Remove:
  - Generator rotor "1"  
(with the flywheel puller "2")
  - Woodruff key

ECA13880

## NOTICE

To protect the end of the crankshaft, place an appropriate sized socket between the flywheel puller set center bolt and the crankshaft.

### TIP

Make sure the flywheel puller is centered over the generator rotor.



**Flywheel puller**  
90890-01362  
**Heavy duty puller**  
YU-33270-B

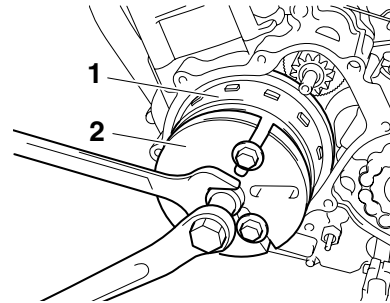

EAS24560

## REMOVING THE STARTER CLUTCH

1. Remove:
  - Starter clutch bolts "1"

### TIP

- While holding the generator rotor "2" with the sheave holder "3", remove the starter clutch bolts.
- Do not allow the sheave holder to touch the projections on the generator rotor.



**Sheave holder**  
90890-01701  
**Primary clutch holder**  
YS-01880-A

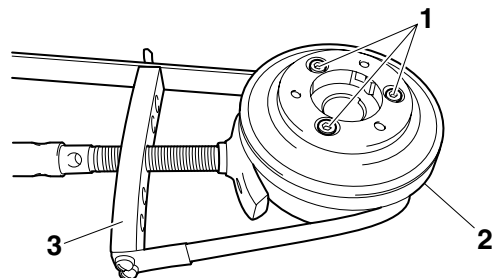



# YamahaR125.COM GENERATOR AND STARTER CLUTCH

EAS24570

## CHECKING THE STARTER CLUTCH

1. Check:
- Starter clutch rollers "1"
  - Starter clutch spring caps "2"
  - Starter clutch springs "3"
- Damage/wear → Replace the starter clutch assembly.

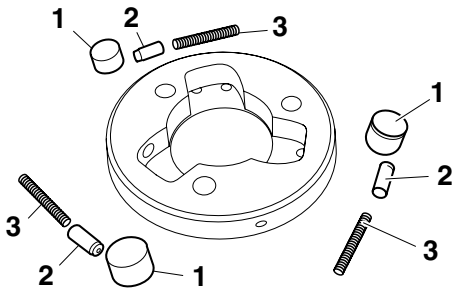

2. Check:
- Starter clutch idle gear
  - Starter clutch gear
- Burrs/chips/roughness/wear → Replace the defective part(s).
3. Check:
- Starter clutch gear contact surfaces
- Damage/pitting/wear → Replace the starter clutch gear.
4. Check:
- Starter clutch operation
- 
- a. Install the starter clutch gear "1" onto the starter clutch and hold the generator rotor.
- b. When turning the starter clutch gear clockwise "A", the starter clutch and the starter clutch gear should engage, otherwise the starter clutch is faulty and must be replaced.
- c. When turning the starter clutch gear counter-clockwise "B", it should turn freely, otherwise the starter clutch is faulty and must be replaced.

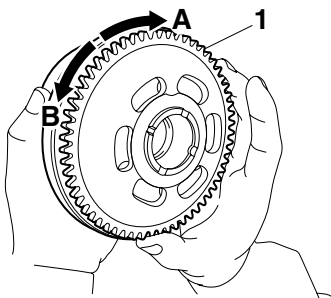

EAS24600

## INSTALLING THE STARTER CLUTCH

1. Install:
- Starter clutch assembly
  - Starter clutch bolts "1"



**Starter clutch bolt**  
**14 Nm (1.4 m·kgf, 10 ft·lbf)**  
**LOCTITE®**

### TIP

- While holding the generator rotor "2" with the sheave holder "3", tighten the starter clutch bolts.
- Do not allow the sheave holder to touch the projections on the generator rotor.



**Sheave holder**  
**90890-01701**  
**Primary clutch holder**  
**YS-01880-A**

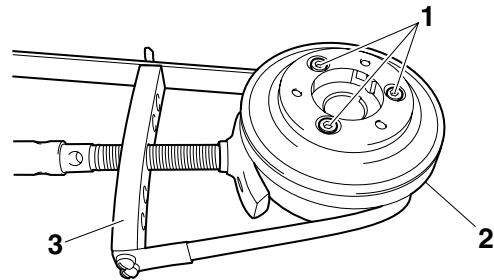

EAS24500

## INSTALLING THE GENERATOR

1. Install:
- Woodruff key
  - Generator rotor
  - Washer
  - Generator rotor nut

### TIP

- Clean the tapered portion of the crankshaft and the generator rotor hub.
- When installing the generator rotor, make sure the woodruff key is properly sealed in the key-way of the crankshaft.

2. Tighten:
- Generator rotor nut "1"



**Generator rotor nut**  
**70 Nm (7.0 m·kgf, 50 ft·lbf)**

# YamahaR125.COM GENERATOR AND STARTER CLUTCH

## TIP

- While holding the generator rotor "2" with the sheave holder "3", tighten the generator rotor nut.
- Do not allow the sheave holder to touch the projections on the generator rotor.

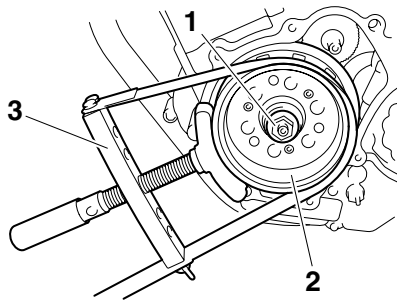
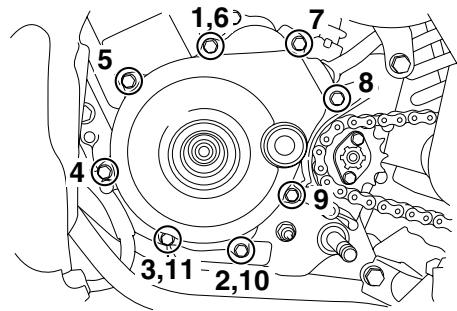

3. Apply:
- Sealant  
(to the crankshaft position sensor/stator assembly lead grommet)

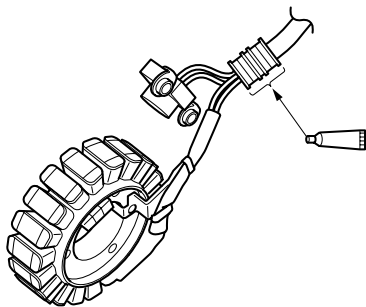
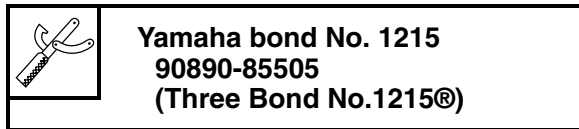

4. Install:
- Generator cover

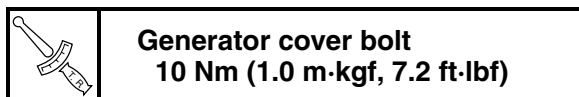

## TIP

Tighten the generator cover bolts in the proper tightening sequence as shown.

EAS24780

## ELECTRIC STARTER

### Removing the starter motor



 10 Nm (1.0 m·kgf, 7.2 ft·lbf)

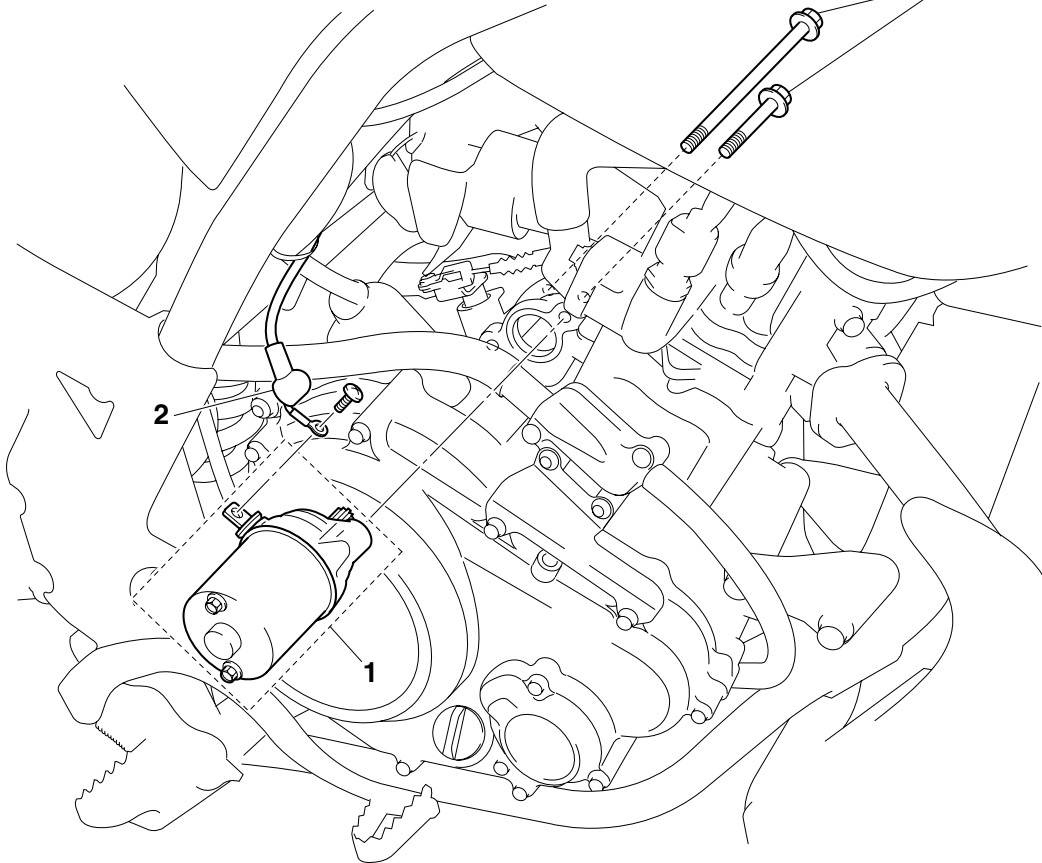

Order	Job/Parts to remove	Q'ty	Remarks
1	Starter motor	1	
2	Starter motor lead	1	Disconnect.
			For installation, reverse the removal procedure.

Disassembling the starter motor

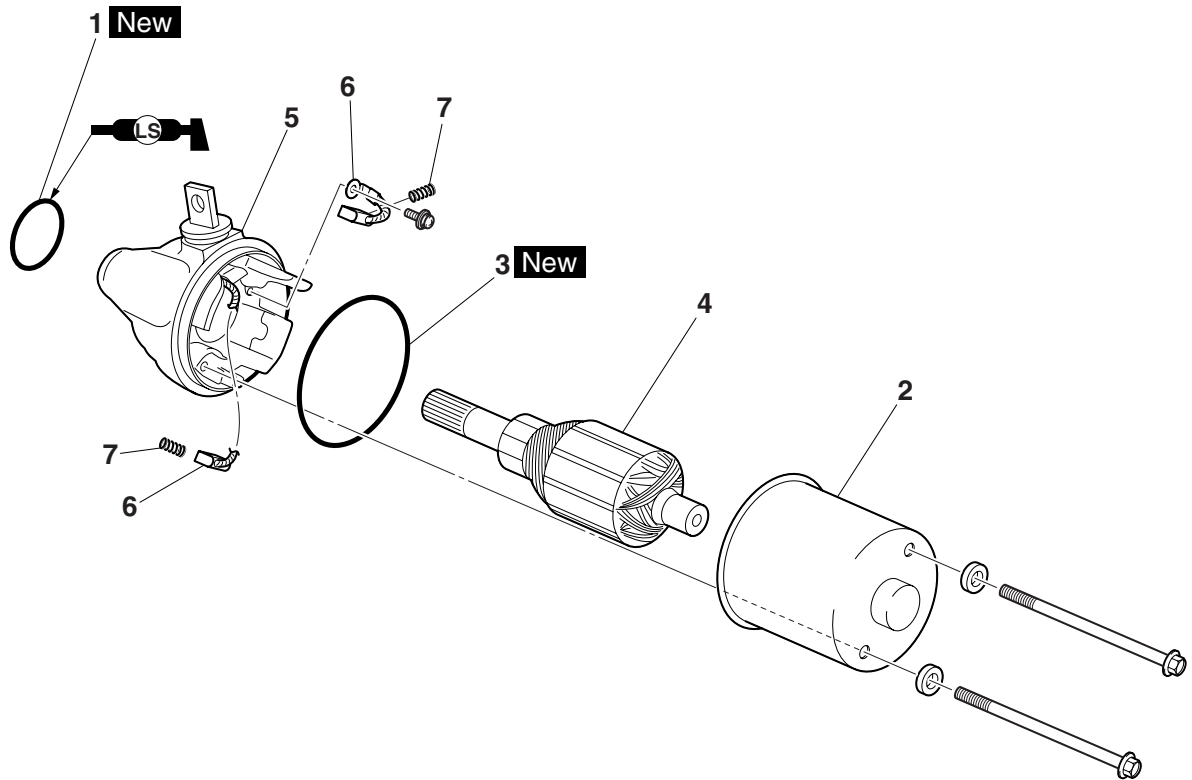

Order	Job/Parts to remove	Q'ty	Remarks
1	O-ring	1	
2	Starter motor yoke	1	
3	O-ring	1	
4	Armature assembly	1	
5	Starter motor front cover/brush holder set	1	
6	Brush	2	
7	Brush spring	2	
			For assembly, reverse the disassembly procedure.



7. Check:

- Gear teeth  
Damage/wear → Replace the starter motor.

8. Check:

- Bearing
- Oil seal  
Damage/wear → Replace the starter motor front cover/brush holder set.

EAS24800

### ASSEMBLING THE STARTER MOTOR

1. Install:

- Starter motor front cover/brush holder set "1"
- Starter motor yoke "2"

**TIP**

Align the marks "a" on the starter motor yoke and starter motor front cover/brush holder set.

---

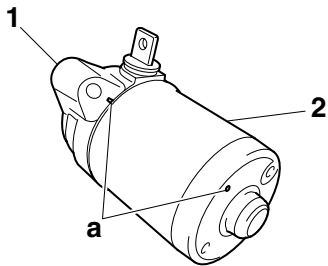

EAS25061

## CLUTCH

### Removing the clutch cover

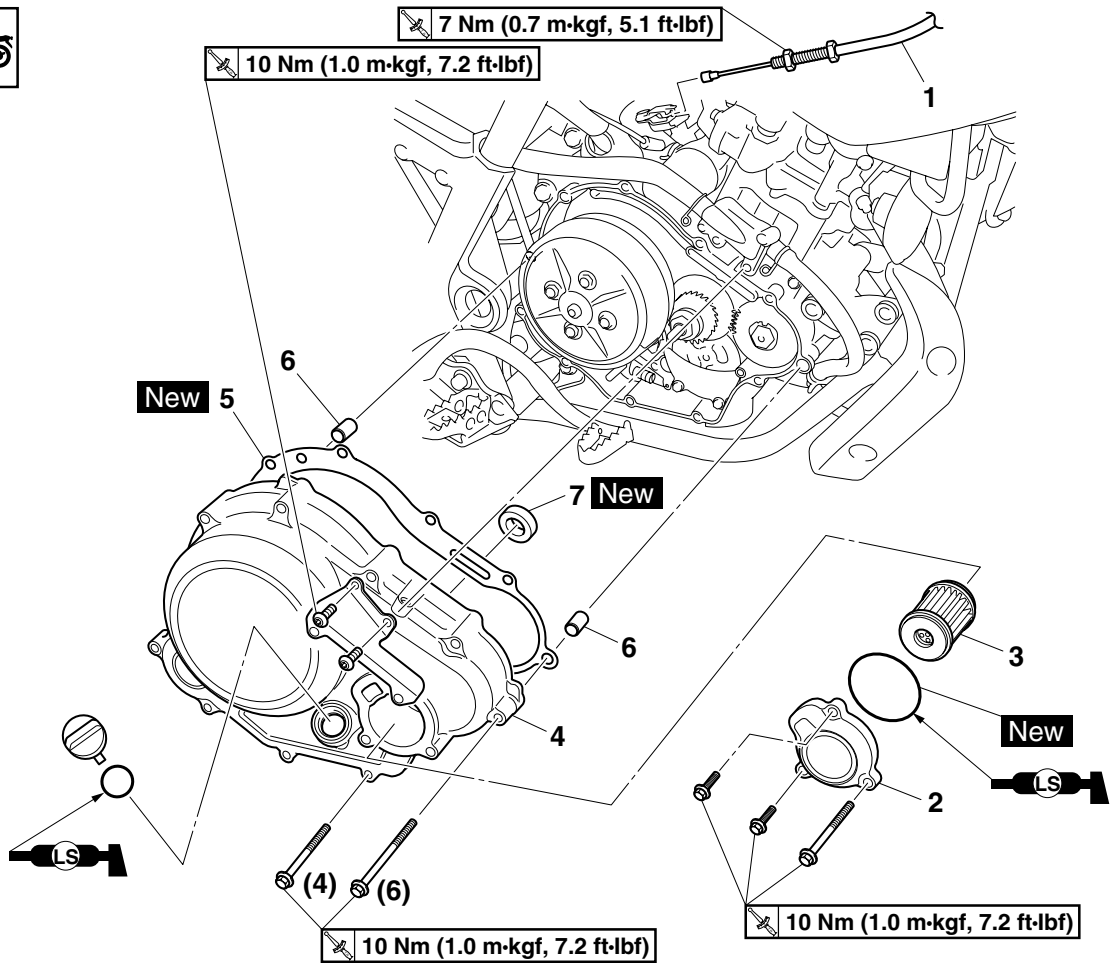

Order	Job/Parts to remove	Q'ty	Remarks
	Engine oil		Drain. Refer to "CHANGING THE ENGINE OIL" on page 3-10.
1	Clutch cable	1	Disconnect.
2	Oil filter element cover	1	
3	Oil filter element	1	
4	Clutch cover	1	
5	Clutch cover gasket	1	
6	Dowel pin	2	
7	Oil seal	1	
			For installation, reverse the removal procedure.

Removing the clutch

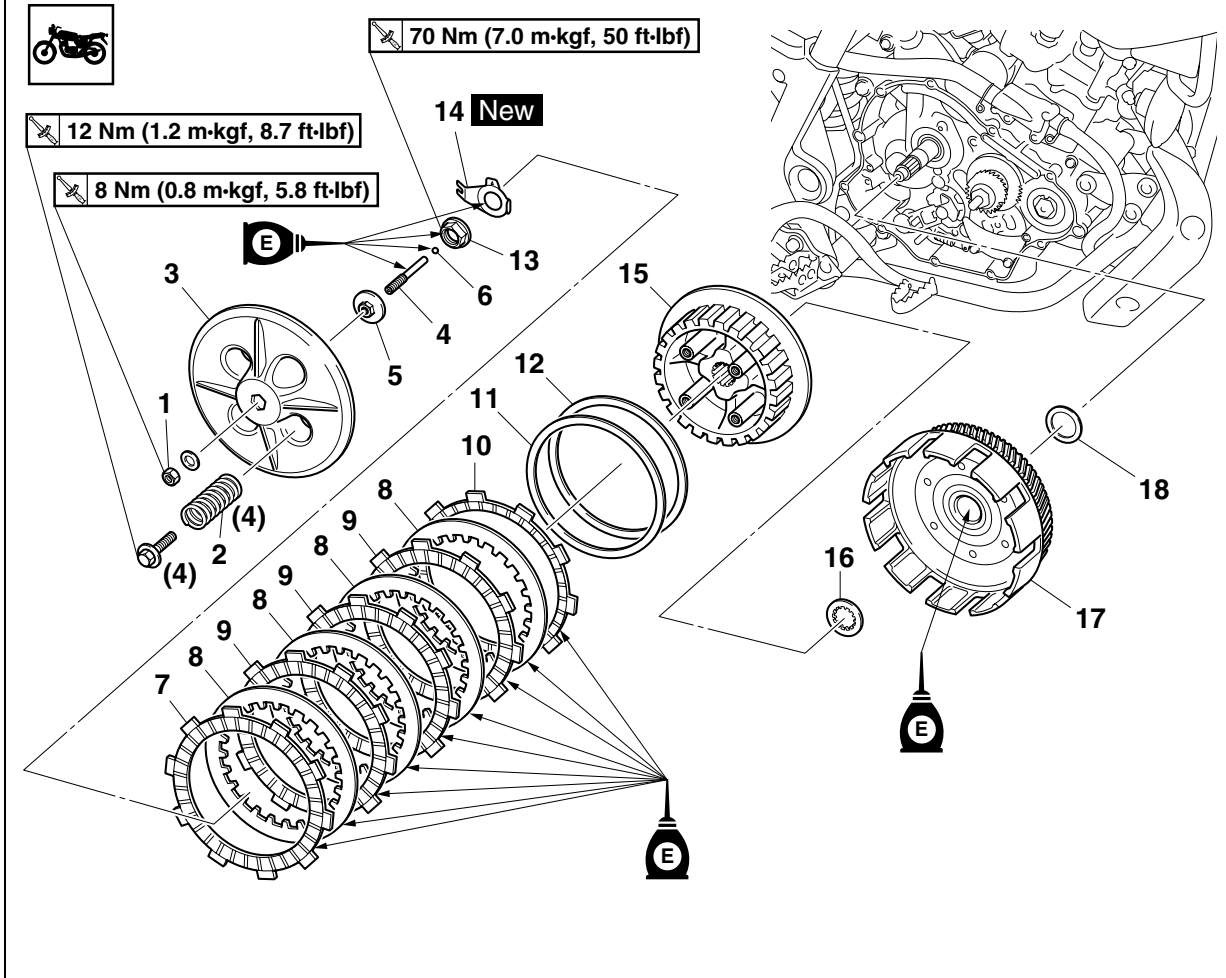

Order	Job/Parts to remove	Q'ty	Remarks
1	Locknut	1	
2	Clutch spring	4	
3	Pressure plate	1	
4	Short clutch push rod	1	
5	Short clutch push rod holder	1	
6	Ball	1	
7	Friction plate 1	1	
8	Clutch plate	4	
9	Friction plate 3	3	Green paint mark
10	Friction plate 2	1	
11	Clutch damper spring	1	
12	Clutch damper spring seat	1	
13	Clutch boss nut	1	
14	Lock washer	1	
15	Clutch boss	1	
16	Thrust washer	1	
17	Clutch housing	1	



Removing the clutch

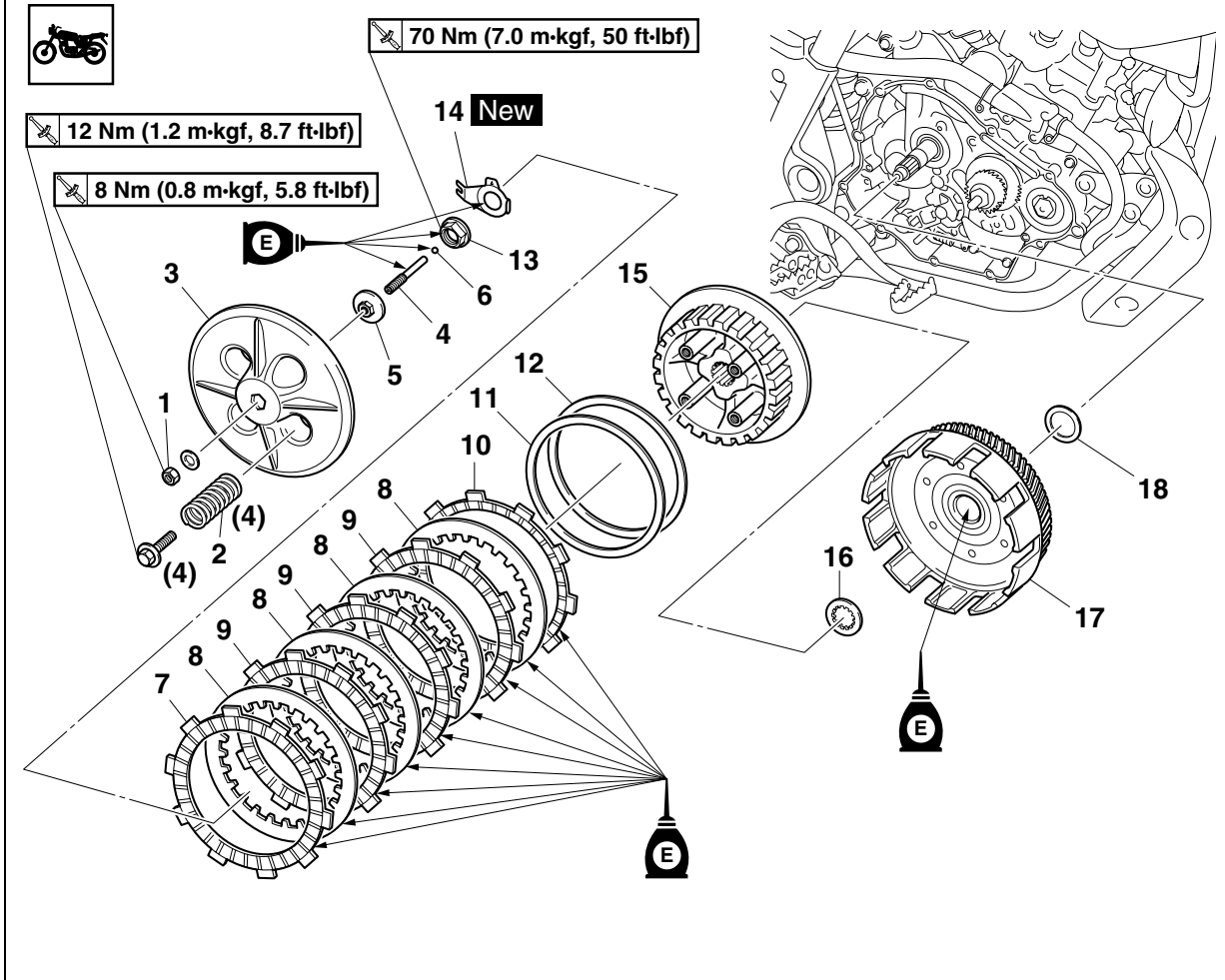

Order	Job/Parts to remove	Q'ty	Remarks
18	Conical spring washer	1	
			For installation, reverse the removal procedure.

Removing the push lever

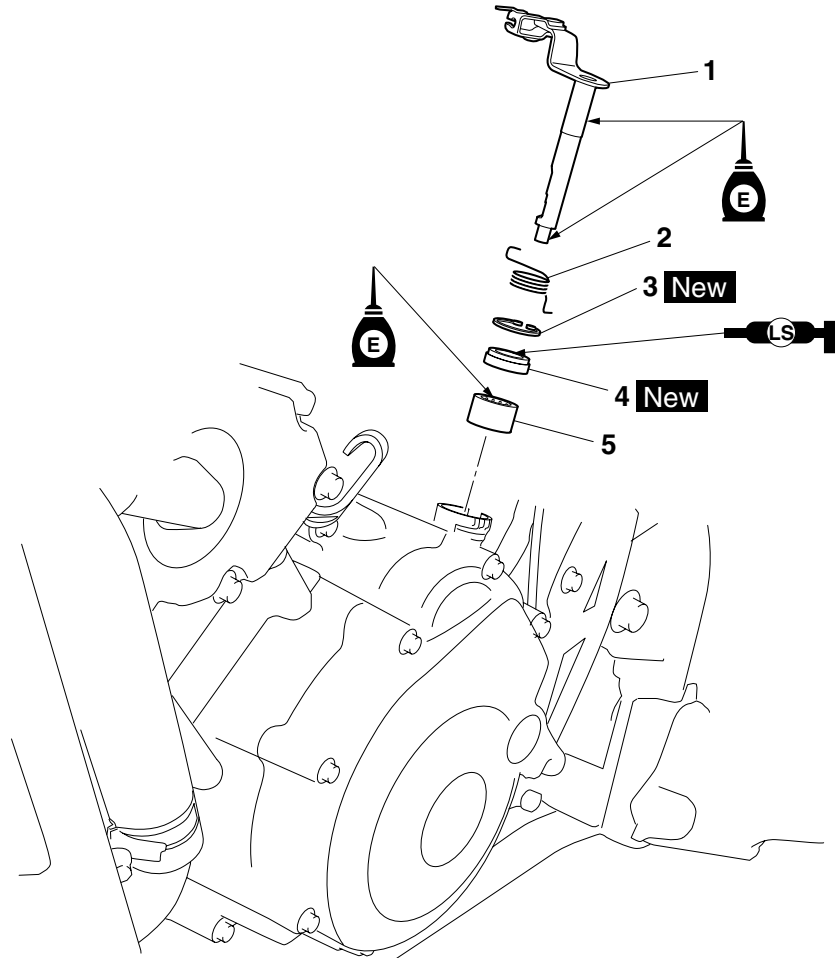

Order	Job/Parts to remove	Q'ty	Remarks
	Exhaust pipe		Refer to "ENGINE REMOVAL" on page 5-1.
1	Clutch push lever	1	
2	Clutch push lever spring	1	
3	Circlip	1	
4	Oil seal	1	
5	Bearing	1	
			For installation, reverse the removal procedure.

EAS25070

## REMOVING THE CLUTCH

- Remove:
  - Clutch cover

### TIP

Loosen each bolt 1/4 of a turn at a time, in stages and in a crisscross pattern. After all of the bolts are fully loosened, remove them.

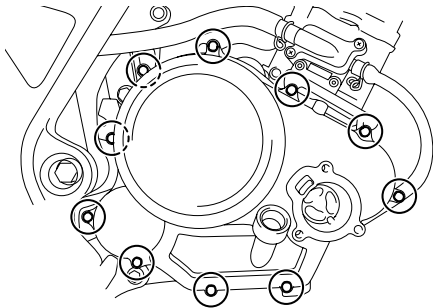

- Straighten the lock washer tab.
- Loosen:
  - Clutch boss nut "1"

### TIP

While holding the clutch boss "2" with the universal clutch holder "3", loosen the clutch boss nut.



**Universal clutch holder**  
90890-04086  
YM-91042

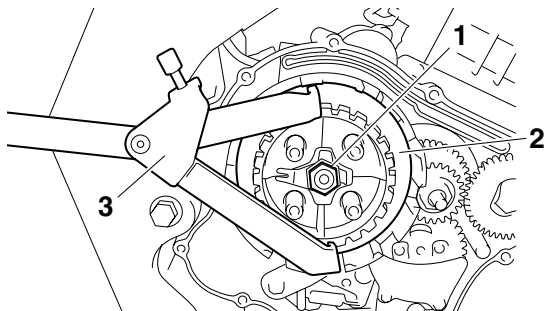

EAS25100

## CHECKING THE FRICTION PLATES

The following procedure applies to all of the friction plates.

- Check:
  - Friction plate  
Damage/wear → Replace the friction plates as a set.
- Measure:
  - Friction plate thickness  
Out of specification → Replace the friction plates as a set.

### TIP

Measure the friction plate at four places.



**Friction plate 1 thickness**  
2.90–3.10 mm (0.114–0.122 in)  
**Wear limit**  
2.80 mm (0.110 in)  
**Friction plate 2 thickness**  
2.90–3.10 mm (0.114–0.122 in)  
**Wear limit**  
2.80 mm (0.1102 in)  
**Friction plate 3 thickness**  
2.90–3.10 mm (0.114–0.122 in)  
**Wear limit**  
2.80 mm (0.1102 in)

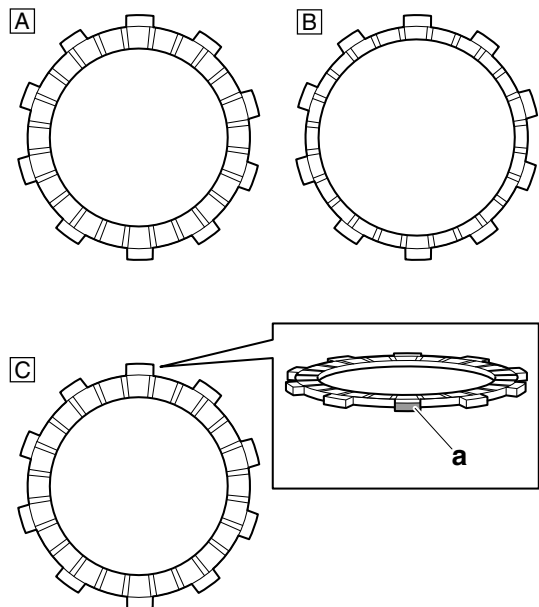
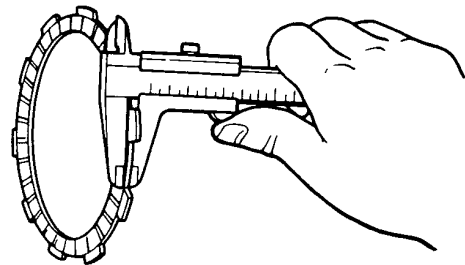

- A. Friction plate 1
- B. Friction plate 2
- C. Friction plate 3
- a. Green paint mark

EAS25110

## CHECKING THE CLUTCH PLATES

The following procedure applies to all of the clutch plates.

1. Check:
  - Clutch plate  
Damage → Replace the clutch plates as a set.
2. Measure:
  - Clutch plate warpage  
(with a surface plate and thickness gauge "1")  
Out of specification → Replace the clutch plates as a set.



**Thickness gauge**  
90890-03180  
**Feeler gauge set**  
YU-26900-9



**Clutch plate thickness**  
1.45–1.75 mm (0.057–0.069 in)  
**Warpage limit**  
0.20 mm (0.0079 in)

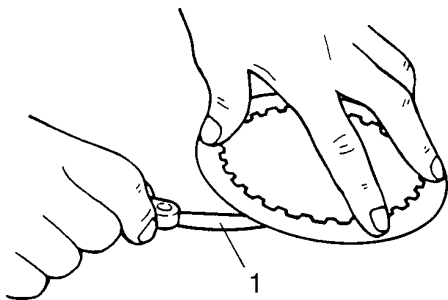

EAS25140

## CHECKING THE CLUTCH SPRINGS

The following procedure applies to all of the clutch springs.

1. Check:
  - Clutch spring  
Damage → Replace the clutch springs as a set.
2. Measure:
  - Clutch spring free length "a"  
Out of specification → Replace the clutch springs as a set.



**Clutch spring free length**  
38.71 mm (1.52 in)  
**Minimum length**  
36.77 mm (1.45 in)

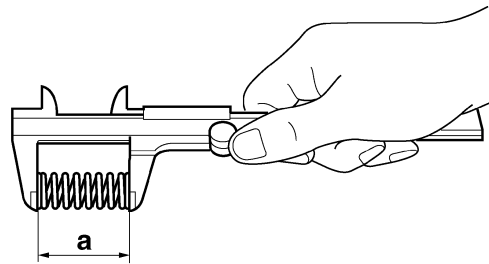

EAS25150

## CHECKING THE CLUTCH HOUSING

1. Check:
  - Clutch housing dogs "1"  
Damage/pitting/wear → Deburr the clutch housing dogs or replace the clutch housing.

### TIP

Pitting on the clutch housing dogs will cause erratic clutch operation.

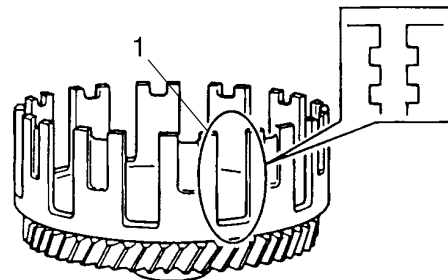

2. Check:
  - Bearing  
Damage/wear → Replace the bearing and clutch housing.

EAS25160

## CHECKING THE CLUTCH BOSS

1. Check:
  - Clutch boss splines  
Damage/pitting/wear → Replace the clutch boss.

### TIP

Pitting on the clutch boss splines will cause erratic clutch operation.

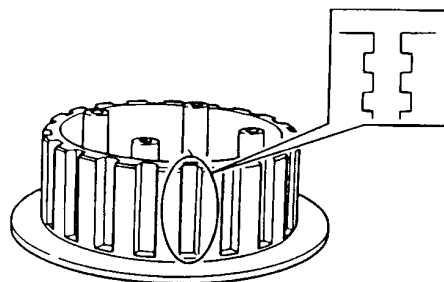

EAS25170

## CHECKING THE PRESSURE PLATE

1. Check:
  - Pressure plate  
Cracks/damage → Replace.

EAS22B1007

## CHECKING THE CLUTCH PUSH LEVER AND SHORT CLUTCH PUSH ROD

1. Check:
  - Clutch push lever
  - Short clutch push rod  
Damage/wear → Replace the defective part(s).

EAS25200

## CHECKING THE PRIMARY DRIVE GEAR

1. Remove:
  - Primary drive gear  
Refer to “BALANCER GEARS” on page 5-53.
2. Check:
  - Primary drive gear  
Damage/wear → Replace the primary drive gear and clutch housing as a set.  
Excessive noise during operation → Replace the primary drive gear and clutch housing as a set.
3. Install:
  - Primary drive gear  
Refer to “BALANCER GEARS” on page 5-53.

EAS25210

## CHECKING THE PRIMARY DRIVEN GEAR

1. Check:
  - Primary driven gear “1”  
Damage/wear → Replace the primary drive gear and clutch housing as a set.  
Excessive noise during operation → Replace the primary drive gear and clutch housing as a set.

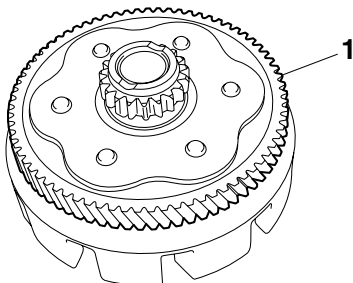

EAS25240

## INSTALLING THE CLUTCH

1. Install:
  - Conical spring washer “1”

### TIP

Install the conical spring washer as shown in the illustration.

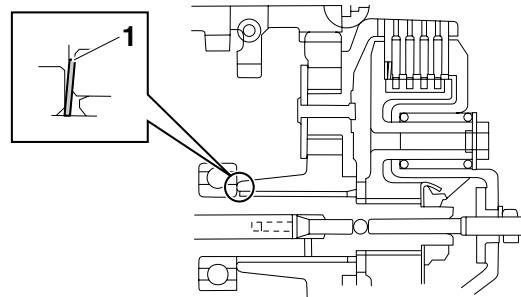

2. Install:
  - Clutch housing
  - Thrust washer “1”

### TIP

Be sure to install the thrust washer so that its sharp edge “a” is facing away from the clutch boss.

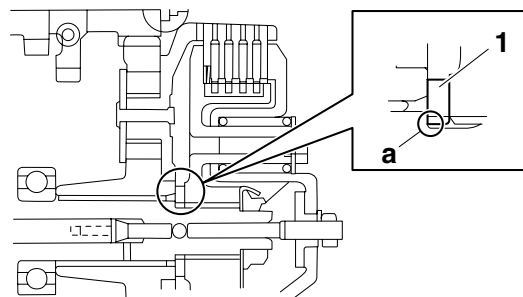

3. Install:
  - Clutch boss “1”
  - Lock washer “2” **New**
  - Clutch boss nut

### TIP

- Lubricate the clutch boss nut threads and lock washer mating surfaces with engine oil.
- Align the notch “a” in the lock washer with a rib “b” on the clutch boss.

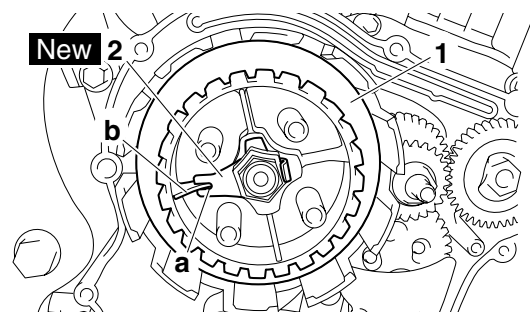

4. Tighten:

- Clutch boss nut “1”

	<b>Clutch boss nut</b> 70 Nm (7.0 m·kgf, 50 ft·lbf)
---	--

**TIP**

While holding the clutch boss “2” with the universal clutch holder “3”, tighten the clutch boss nut.

	<b>Universal clutch holder</b> 90890-04086 YM-91042
---	---

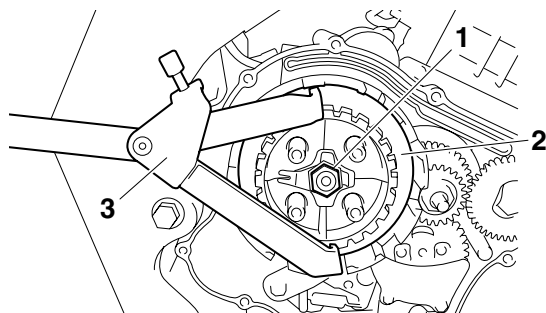

5. Bend the lock washer tab along a flat side of the nut.
6. Lubricate:
  - Friction plates
  - Clutch plates (with the recommended lubricant)

	<b>Recommended lubricant</b> <b>Engine oil</b>
---	---

7. Install:
  - Clutch damper spring seat “1”
  - Clutch damper spring “2”
  - Friction plate 2 “3”
  - Clutch plates “4”
  - Friction plates 3 “5”
  - Friction plate 1 “6”

**TIP**

- Install the clutch damper spring seat and clutch damper spring as shown in the illustration.
- First, install a friction plate and then alternate between a clutch plate and a friction plate.

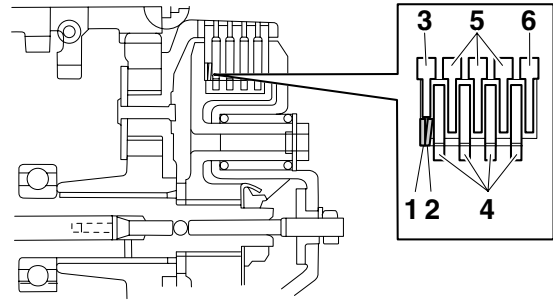

8. Install:

- Pressure plate
- Clutch springs
- Clutch spring bolts “1”

	<b>Clutch spring bolt</b> 12 Nm (1.2 m·kgf, 8.7 ft·lbf)
---	--

**TIP**

Tighten the clutch spring bolts in stages and in a crisscross pattern.

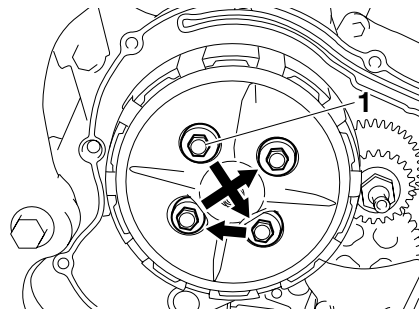

9. Adjust:

- Clutch mechanism free play

- a. Check that the projection “a” on the clutch push lever “1” aligns with the mark “b” shown on the crankcase in the illustration by pushing the clutch push lever manually in direction “c” until it stops.

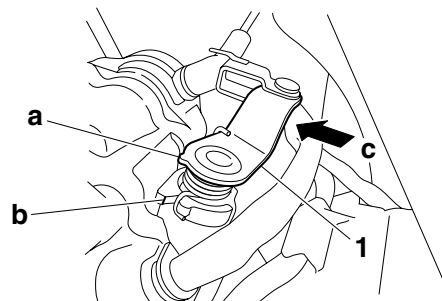

- b. If the projection “a” is not aligned with the mark “b”, align them as follows:
  - Loosen the locknut “2”.



EAS24911

**OIL PUMP**

**Removing the oil pump**

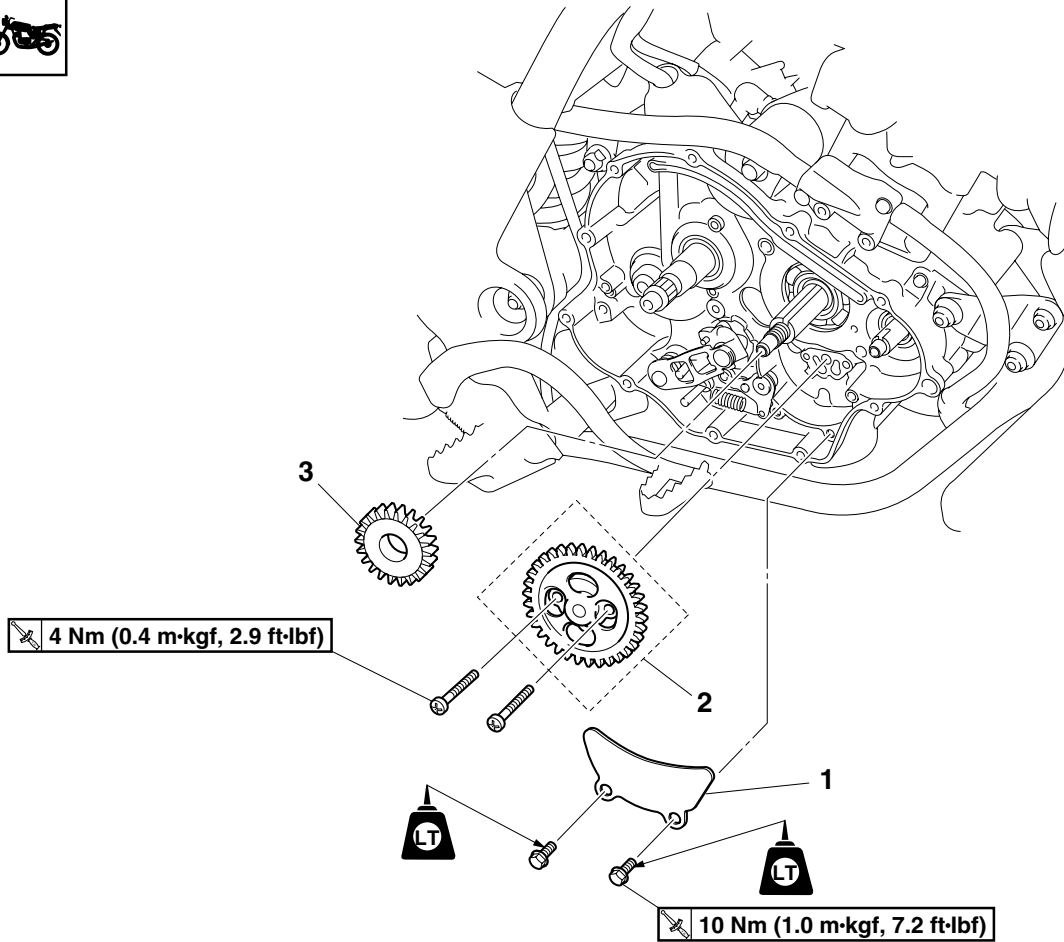

Order	Job/Parts to remove	Q'ty	Remarks
	Clutch housing		Refer to "CLUTCH" on page 5-38.
	Balancer drive gear		Refer to "BALANCER GEARS" on page 5-53.
1	Oil baffle plate	1	
2	Oil pump assembly	1	
3	Oil pump drive gear	1	
			For installation, reverse the removal procedure.



Disassembling the oil pump

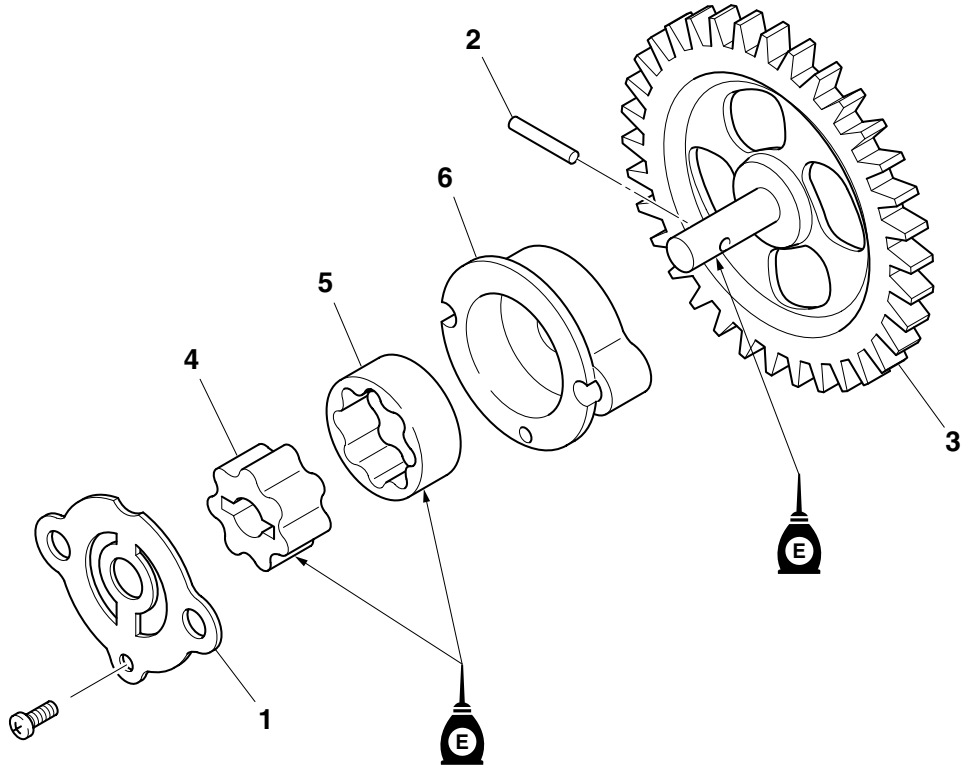

Order	Job/Parts to remove	Q'ty	Remarks
1	Oil pump housing cover	1	
2	Pin	1	
3	Oil pump driven gear	1	
4	Oil pump inner rotor	1	
5	Oil pump outer rotor	1	
6	Oil pump housing	1	
			For assembly, reverse the disassembly procedure.

EAS24960

## CHECKING THE OIL PUMP

### 1. Check:

- Oil pump drive gear
  - Oil pump driven gear
  - Oil pump housing
  - Oil pump housing cover
- Cracks/damage/wear → Replace the defective part(s).

### 2. Measure:

- Inner-rotor-to-outer-rotor-tip clearance “a”
  - Outer-rotor-to-oil-pump-housing clearance “b”
  - Oil-pump-housing-to-inner-rotor-and-outer-rotor clearance “c”
- Out of specification → Replace the oil pump.

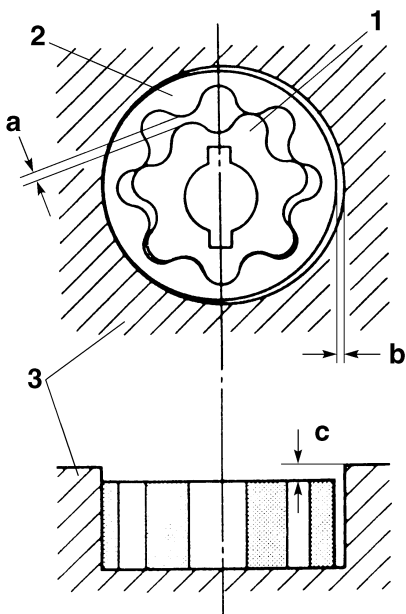

1. Inner rotor
2. Outer rotor
3. Oil pump housing



### Inner-rotor-to-outer-rotor-tip clearance

Less than 0.150 mm (0.0059 in)

### Limit

0.23 mm (0.0091 in)

### Outer-rotor-to-oil-pump-housing clearance

0.130–0.180 mm (0.0051–0.0071 in)

### Limit

0.25 mm (0.0098 in)

### Oil-pump-housing-to-inner-and-outer-rotor clearance

0.06–0.11 mm (0.0024–0.0043 in)

### Limit

0.18 mm (0.0071 in)

### 3. Check:

- Oil pump operation
- Rough movement → Repeat steps (1) and (2) or replace the defective part(s).

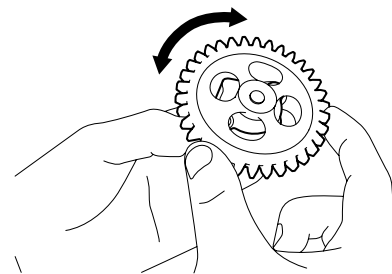

EAS25000

## ASSEMBLING THE OIL PUMP

### 1. Lubricate:

- Oil pump inner rotor
  - Oil pump outer rotor
  - Oil pump driven gear
- (with the recommended lubricant)



**Recommended lubricant**  
**Engine oil**

### 2. Install:

- Oil pump outer rotor
- Oil pump inner rotor “1”
- Oil pump driven gear
- Pin “2”

### TIP

When installing the inner rotor, align the pin “2” in the oil pump shaft with the groove “a” in the inner rotor.

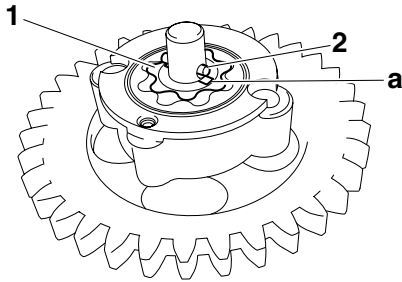

3. Check:

- Oil pump operation  
Refer to "CHECKING THE OIL PUMP" on page 5-49.

EAS25020

### INSTALLING THE OIL PUMP

1. Install:

- Oil pump assembly



**Oil pump assembly screw**  
**4 Nm (0.4 m·kgf, 2.9 ft·lbf)**

ECA22B1011

**NOTICE**

**After tightening the screws, make sure the oil pump turns smoothly.**

EAS25410

**SHIFT SHAFT**

**Removing the shift shaft and stopper lever**

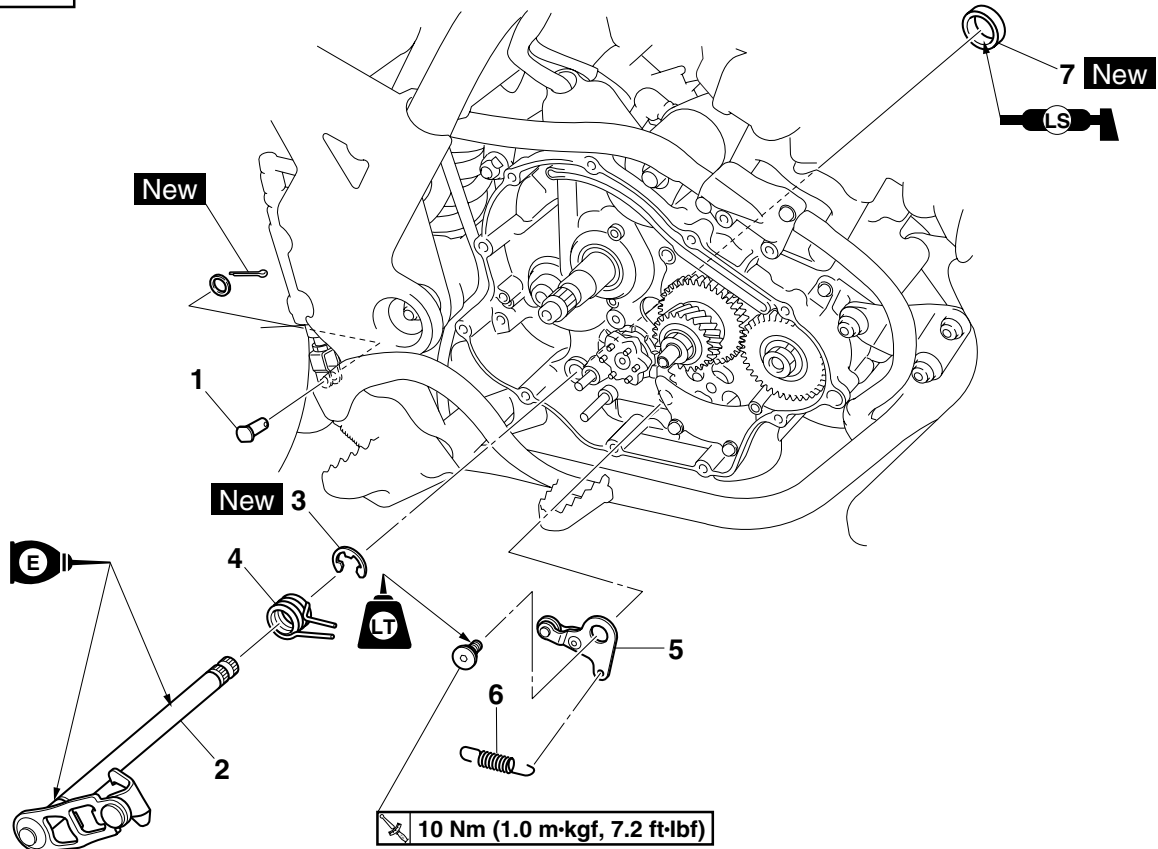

Order	Job/Parts to remove	Q'ty	Remarks
	Clutch housing		Refer to "CLUTCH" on page 5-38.
	Shift pedal		Refer to "ENGINE REMOVAL" on page 5-1.
1	Pin	1	
2	Shift shaft	1	
3	Circlip	1	
4	Shift shaft spring	1	
5	Stopper lever	1	
6	Stopper lever spring	1	
7	Oil seal	1	
			For installation, reverse the removal procedure.

EAS25420

## CHECKING THE SHIFT SHAFT

1. Check:
  - Shift shaft  
Bends/damage/wear → Replace.
  - Shift shaft spring  
Damage/wear → Replace.

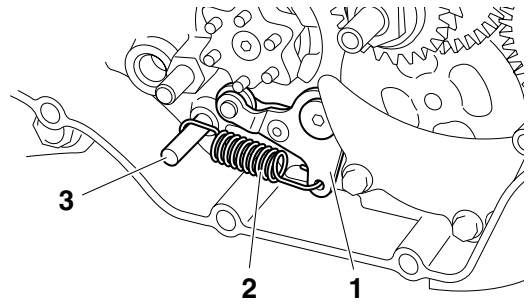

EAS25430

## CHECKING THE STOPPER LEVER

1. Check:
  - Stopper lever  
Bends/damage → Replace.  
Roller turns roughly → Replace the stopper lever.
  - Stopper lever spring  
Damage/wear → Replace.

3. Install:
  - Shift shaft "1"

### TIP

Hook the end of the shift shaft spring onto the shift shaft spring stopper "2".

EAS25450

## INSTALLING THE SHIFT SHAFT

1. Install:
  - Oil seal "1"  
(to the left crankcase "2")

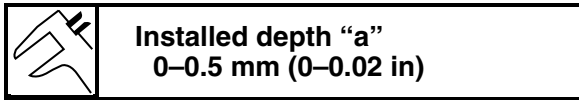

Installed depth "a"  
0–0.5 mm (0–0.02 in)

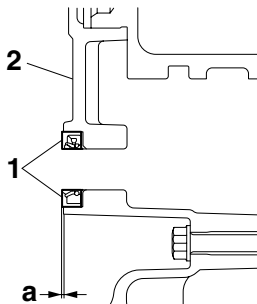

2. Install:
  - Stopper lever "1"
  - Stopper lever spring "2"

### TIP

- Install the stopper lever spring as shown in the illustration.
- Hook the ends of the stopper lever spring onto the stopper lever and the crankcase boss "3".
- Mesh the stopper lever with the shift drum segment assembly.

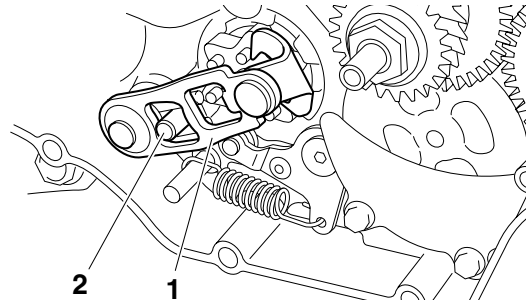

EAS22B1008

## BALANCER GEARS

### Removing the primary drive gear and balancer gears

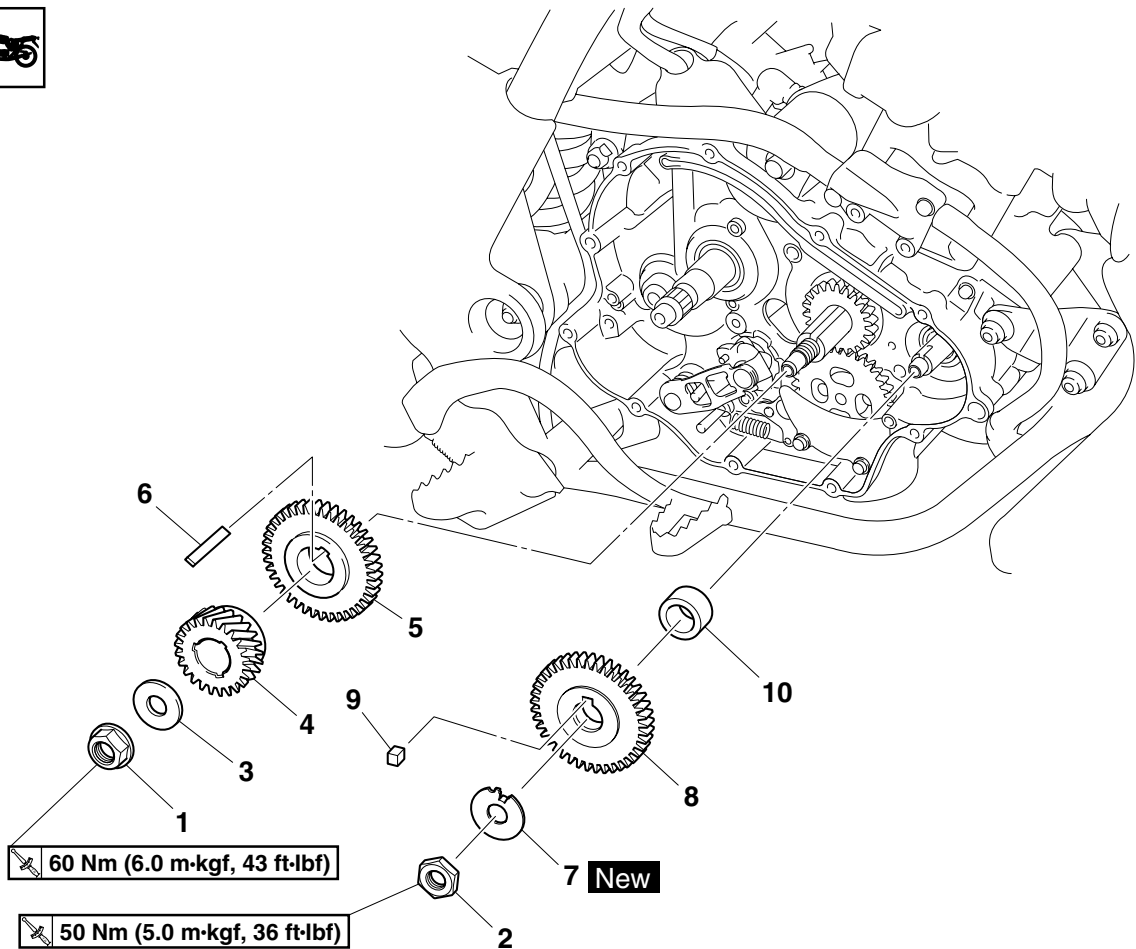

Order	Job/Parts to remove	Q'ty	Remarks
	Clutch housing		Refer to "CLUTCH" on page 5-38.
1	Primary drive gear nut	1	
2	Balancer driven gear nut	1	
3	Washer	1	
4	Primary drive gear	1	
5	Balancer drive gear	1	
6	Straight key	1	
7	Lock washer	1	
8	Balancer driven gear	1	
9	Straight key	1	
10	Spacer	1	
			For installation, reverse the removal procedure.

EAS22B1009

## REMOVING THE PRIMARY DRIVE GEAR AND BALANCER GEARS

- Loosen:
  - Primary drive gear nut "1"

### TIP

Place an aluminum plate "a" between the balancer drive gear "2" and the balancer driven gear "3", and then loosen the primary drive gear nut.

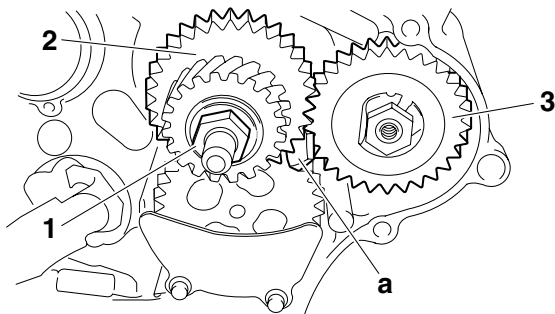

- Straighten the lock washer tab.
- Loosen:
  - Balancer driven gear nut "1"

### TIP

Place an aluminum plate "a" between the balancer drive gear "2" and the balancer driven gear "3", and then loosen the balancer driven gear nut.

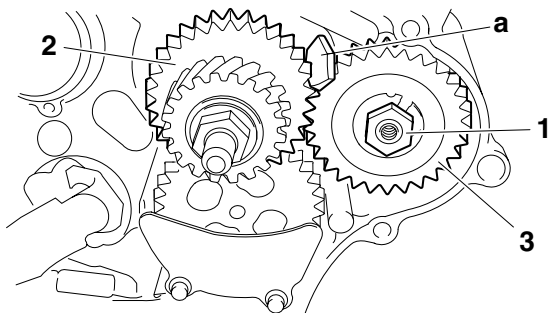

EAS22B1010

## CHECKING THE BALANCER GEARS AND PRIMARY DRIVE GEAR

- Check:
  - Balancer drive gear
  - Balancer driven gear
 Cracks/damage/wear → Replace.
- Check:
  - Primary drive gear
 Refer to "CHECKING THE PRIMARY DRIVE GEAR" on page 5-44.

EAS22B1011

## INSTALLING THE PRIMARY DRIVE GEAR AND BALANCER GEARS

- Install:
  - Balancer driven gear "1"
  - Lock washer **New**
  - Balancer drive gear "2"
  - Primary drive gear
  - Washer "3"
  - Balancer driven gear nut
  - Primary drive gear nut

### TIP

- Align the punch mark "a" in the balancer drive gear "2" with the punch mark "b" in the balancer driven gear "1".
- Be sure to install the washer so that its sharp edge "c" is facing the primary drive gear.

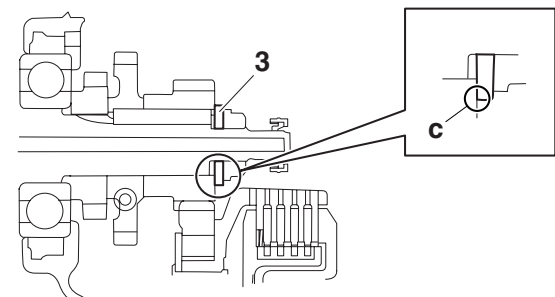
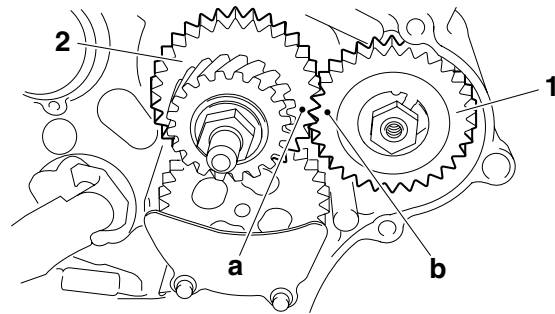

- Tighten:
  - Balancer driven gear nut "1"
  - Primary drive gear nut "2"



**Balancer driven gear nut**  
**50 Nm (5.0 m·kgf, 36 ft·lbf)**  
**Primary drive gear nut**  
**60 Nm (6.0 m·kgf, 43 ft·lbf)**

### TIP

- Place an aluminum plate "a" between the balancer drive gear "3" and the balancer driven gear "4", and then tighten the balancer driven gear nut.

- Place an aluminum plate “b” between the balancer drive gear “3” and the balancer driven gear “4”, and then tighten the primary drive gear nut.

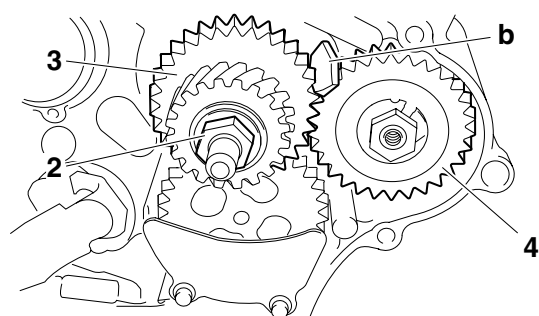
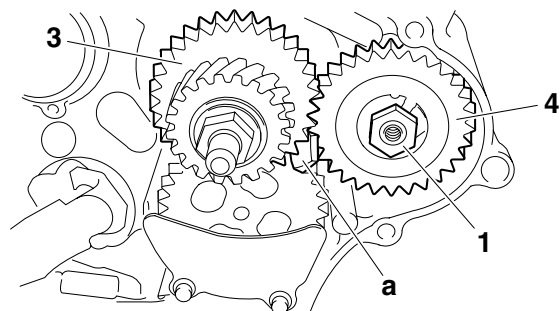

3. Bend the lock washer tab along a flat side of the nut.



EAS25540

## CRANKCASE

### Separating the crankcase

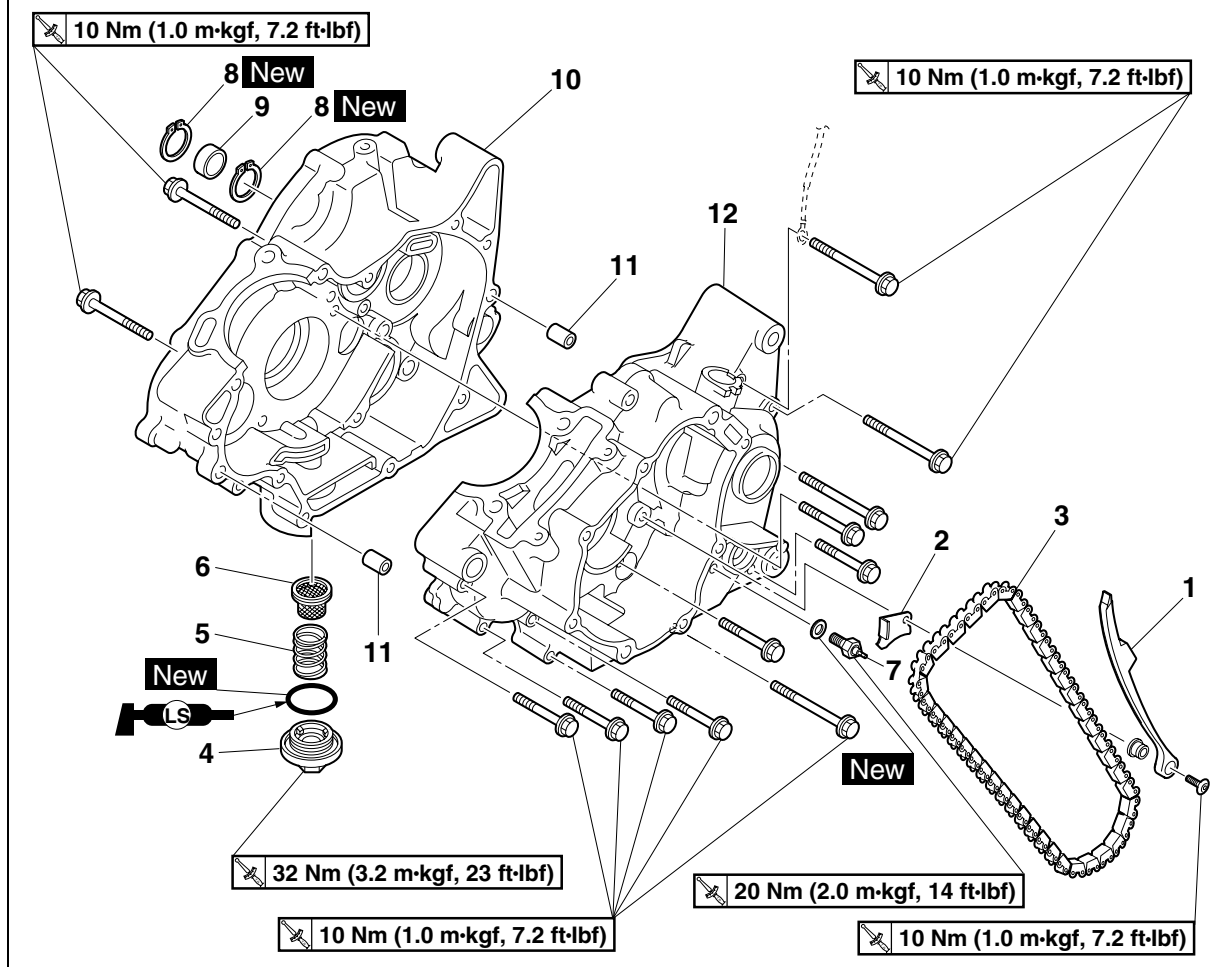

Order	Job/Parts to remove	Q'ty	Remarks
	Engine		Refer to "ENGINE REMOVAL" on page 5-1.
	Cylinder head		Refer to "CYLINDER HEAD" on page 5-7.
	Cylinder/Piston		Refer to "CYLINDER AND PISTON" on page 5-24.
	Clutch housing		Refer to "CLUTCH" on page 5-38.
	Oil pump assembly		Refer to "OIL PUMP" on page 5-47.
	Shift shaft		Refer to "SHIFT SHAFT" on page 5-51.
	Starter motor		Refer to "ELECTRIC STARTER" on page 5-34.
	Balancer gears		Refer to "BALANCER GEARS" on page 5-53.
	Generator rotor		Refer to "GENERATOR AND STARTER CLUTCH" on page 5-29.
1	Timing chain guide (intake side)	1	
2	Timing chain guard	1	
3	Timing chain	1	
4	Engine oil drain plug	1	

Separating the crankcase

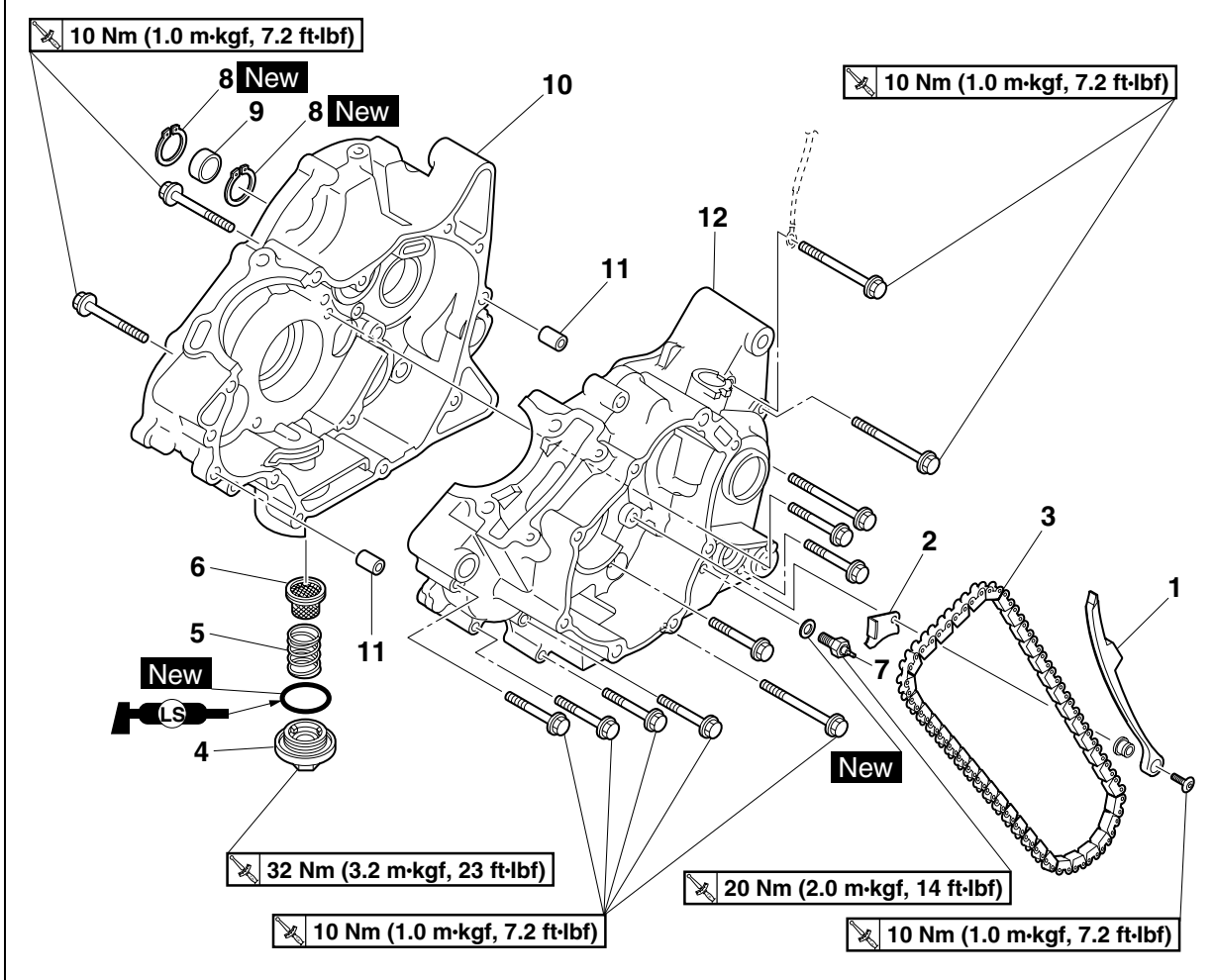

Order	Job/Parts to remove	Q'ty	Remarks
5	Spring	1	
6	Engine oil strainer	1	
7	Neutral switch	1	
8	Circlip	2	
9	Spacer	1	
10	Right crankcase	1	
11	Dowel pin	2	
12	Left crankcase	1	
			For installation, reverse the removal procedure.

Removing the oil seal and bearings

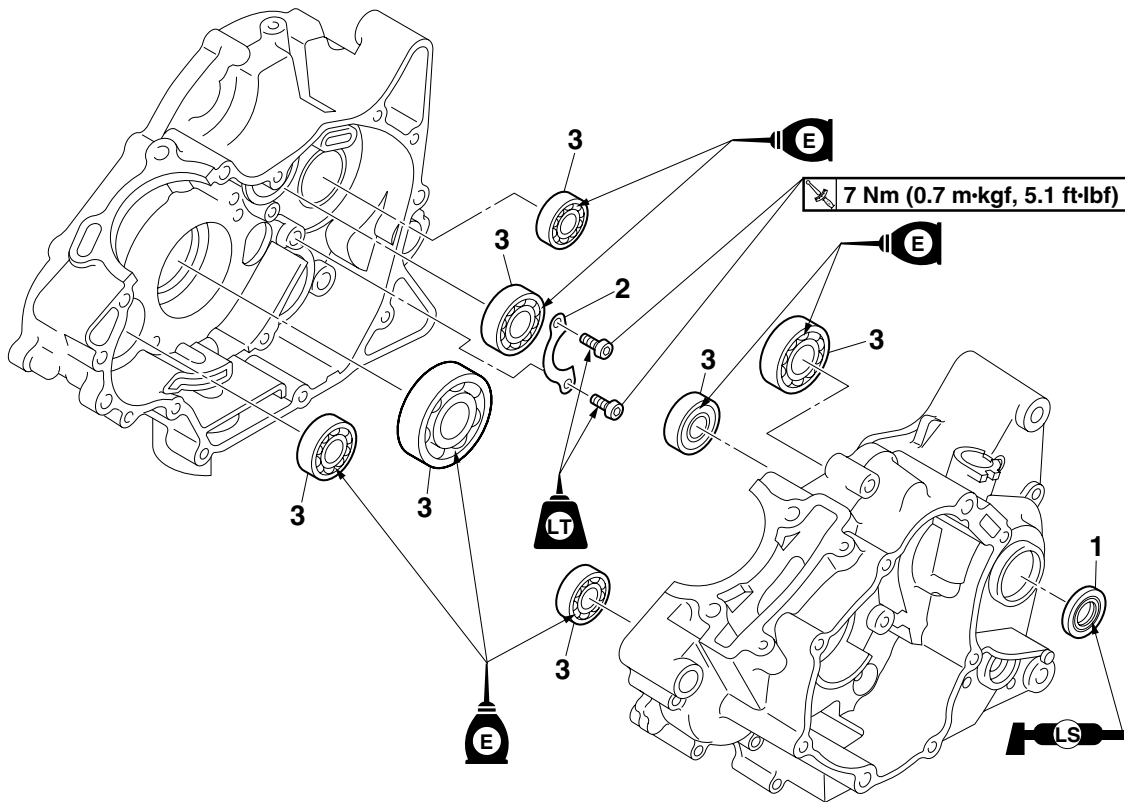

Order	Job/Parts to remove	Q'ty	Remarks
	Crankshaft/Balancer		Refer to "CRANKSHAFT" on page 5-62.
	Transmission		Refer to "TRANSMISSION" on page 5-65.
1	Oil seal	1	
2	Bearing retainer	1	
3	Bearing	7	
			For installation, reverse the removal procedure.

EAS22B1012

## SEPARATING THE CRANKCASE

1. Remove:
  - Crankcase bolts

### TIP

Loosen each bolt 1/4 of a turn at a time, in stages and in a crisscross pattern. After all of the bolts are fully loosened, remove them.

A

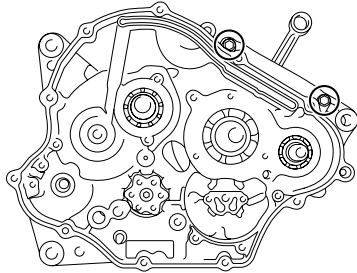

B

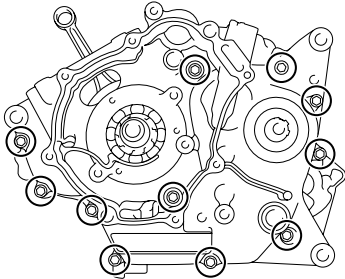

- A. Right crankcase
- B. Left crankcase

2. Turn:
  - Shift drum segment

### TIP

Turn the shift drum segment "1" to the position shown in the illustration. In this position, the shift drum segment teeth will not contact the crankcase during crankcase separation.

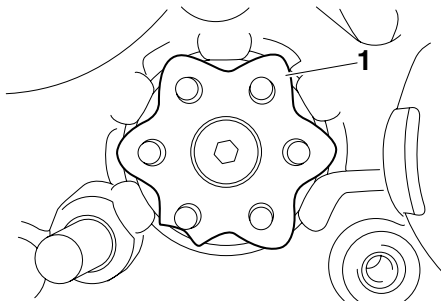

3. Remove:
  - Right crankcase

ECA22B1021

## NOTICE

Tap on one side of the crankcase with a soft-face hammer. Tap only on reinforced portions of the crankcase, not on the crankcase mating surfaces. Work slowly and carefully and make sure the crankcase halves separate evenly.

EAS25580

## CHECKING THE CRANKCASE

1. Thoroughly wash the crankcase halves in a mild solvent.
2. Thoroughly clean all the gasket surfaces and crankcase mating surfaces.
3. Check:
  - Crankcase  
Cracks/damage → Replace.
  - Oil delivery passages  
Obstruction → Blow out with compressed air.

EAS22B1013

## CHECKING THE TIMING CHAIN AND TIMING CHAIN GUIDE

1. Check:
  - Timing chain  
Damage/stiffness → Replace the timing chain and camshaft sprocket as a set.

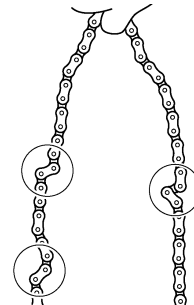

2. Check:
  - Timing chain guide (intake side)  
Damage/wear → Replace.

EAS22B1014

## CHECKING THE OIL STRAINER

1. Check:
  - Oil strainer  
Damage → Replace.  
Contaminants → Clean with solvent.

EAS22B1015

## CHECKING THE BEARINGS AND OIL SEAL

1. Check:
  - Bearings  
Clean and lubricate the bearings, and then rotate the inner race with your finger.  
Rough movement → Replace.

- Oil seal  
Damage/wear → Replace.

EAS22B1016

## INSTALLING THE BEARING RETAINER

1. Install:
  - Bearing retainer “1”

### TIP

- Install the bearing retainer “1” with its “OUT” mark “a” facing outward.
- Apply locking agent (LOCTITE®) to the threads of the bearing retainer bolts.



**Bearing retainer bolt**  
7 Nm (0.7 m·kgf, 5.1 ft·lbf)  
LOCTITE®

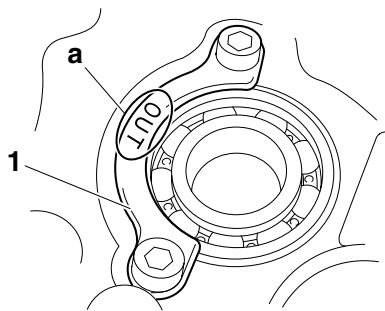

EAS22B1029

## INSTALLING THE OIL SEAL

1. Install:
  - Oil seal “1”  
(to the left crankcase “2”)



**Installed depth “a”**  
1.0–1.5 mm (0.04–0.06 in)

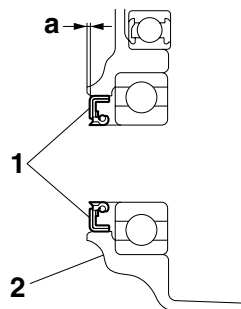

EAS25700

## ASSEMBLING THE CRANKCASE

1. Thoroughly clean all the gasket mating surfaces and crankcase mating surfaces.
2. Apply:
  - Sealant  
(to the crankcase mating surfaces)



**Yamaha bond No. 1215**  
90890-85505  
(Three Bond No.1215®)

### TIP

Do not allow any sealant to come into contact with the oil gallery.

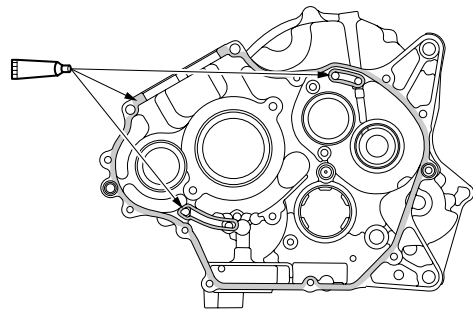

3. Install:
  - Right crankcase  
(onto the left crankcase)

### TIP

- Turn the shift drum segment “1” to the position shown in the illustration. In this position, the shift drum segment teeth will not contact the crankcase during crankcase installation.
- Tap lightly on the right crankcase with a soft-face hammer.

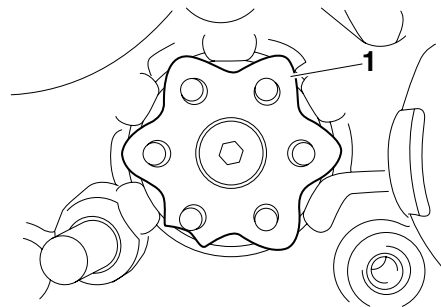

4. Install:
  - Crankcase bolts



**Crankcase bolt**  
10 Nm (1.0 m·kgf, 7.2 ft·lbf)

### TIP

Tighten each bolt 1/4 of a turn at a time, in stages and in the proper sequence as shown.

- M6 × 70 mm : “8–10”, “12”
- M6 × 55 mm : “15”, “16”
- M6 × 45 mm : “1–6”, “11”

A

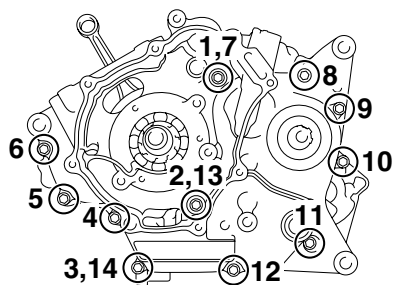

B

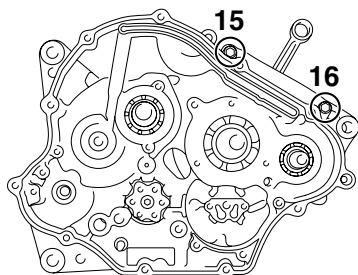

- A. Left crankcase
- B. Right crankcase

EAS25960

**CRANKSHAFT**

**Removing the crankshaft and balancer**

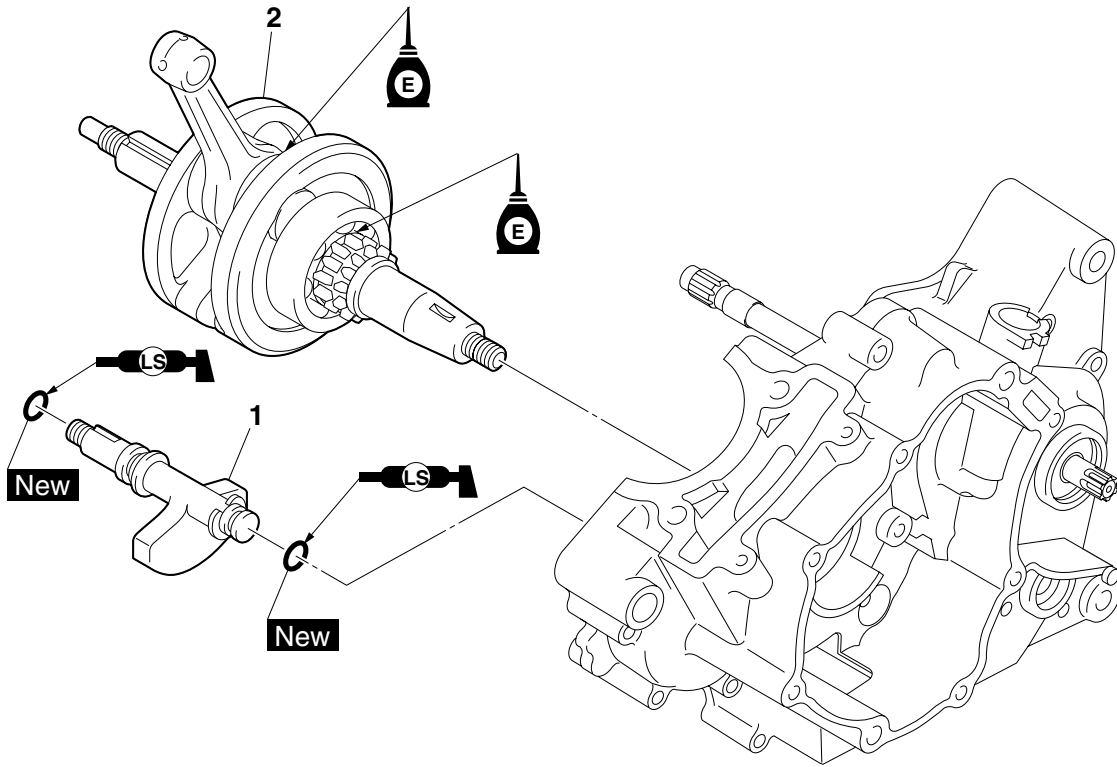

Order	Job/Parts to remove	Q'ty	Remarks
	Crankcase		Separate. Refer to "CRANKCASE" on page 5-56.
1	Balancer	1	
2	Crankshaft	1	
			For installation, reverse the removal procedure.

EAS22B1017

## REMOVING THE CRANKSHAFT

1. Remove:
  - Crankshaft "1"

### TIP

- Remove the crankshaft with the crankcase separating tool "2".
- Make sure the crankcase separating tool is centered over the crankshaft.

ECA22B1006

### NOTICE

- To protect the end of the crankshaft, place an appropriate sized socket between the crankcase separating tool bolt and the crankshaft.
- Do not tap on the crankshaft.



**Crankcase separating tool  
90890-01135  
Crankcase separator  
YU-01135-B**

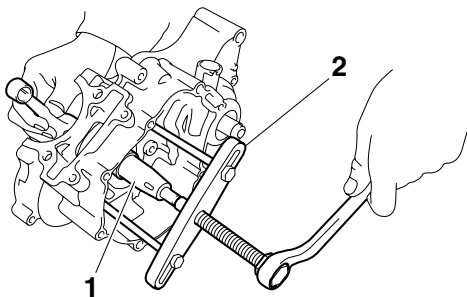

EAS22B1018

## CHECKING THE CRANKSHAFT

1. Measure:
  - Crankshaft runout  
Out of specification → Replace the crankshaft, bearing or both.

### TIP

Turn the crankshaft slowly.



**Runout limit C  
0.030 mm (0.0012 in)**

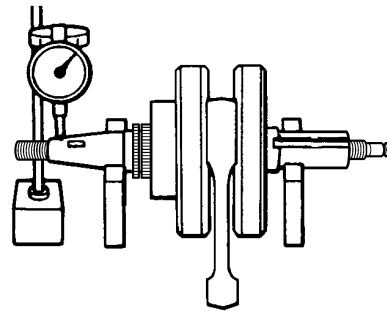

2. Measure:
  - Big end side clearance  
Out of specification → Replace the crankshaft.



**Big end side clearance D  
0.110–0.410 mm (0.0043–0.0161 in)**

3. Measure:
  - Crankshaft width  
Out of specification → Replace the crankshaft.



**Width A  
47.95–48.00 mm (1.888–1.890 in)**

4. Check:
  - Crankshaft sprocket  
Damage/wear → Replace the crankshaft.
  - Bearing  
Cracks/damage/wear → Replace the crankshaft.
5. Check:
  - Crankshaft journal  
Scratches/wear → Replace the crankshaft.
  - Crankshaft journal oil passage  
Obstruction → Blow out with compressed air.

EAS22B1019

## INSTALLING THE CRANKSHAFT

1. Install:
  - Crankshaft "1"

### TIP

Install the crankshaft with the crankshaft installer pot "2", crankshaft installer bolt "3", adapter (M12) "4" and spacer (crankshaft installer) "5".



	<b>Crankshaft installer pot</b> 90890-01274
	<b>Installing pot</b> YU-90058
	<b>Crankshaft installer bolt</b> 90890-01275
	<b>Bolt</b> YU-90060
	<b>Adapter (M12)</b> 90890-01278
	<b>Adapter #3</b> YU-90063
	<b>Spacer (crankshaft installer)</b> 90890-04081
	<b>Pot spacer</b> YM-91044

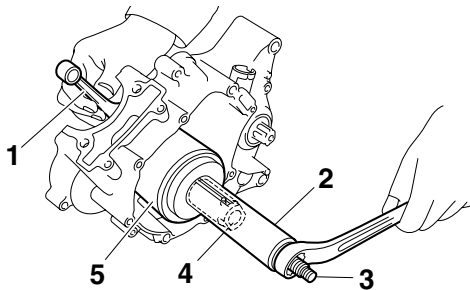

ECA22B1022

**NOTICE**

To avoid scratching the crankshaft and to ease the installation procedure, lubricate the oil seal lips with lithium-soap-based grease and each bearing with engine oil.

**TIP**

Hold the connecting rod at top dead center (TDC) with one hand while turning the nut of the crankshaft installer bolt with the other. Turn the crankshaft installer bolt until the crankshaft bottoms against the bearing.

EAS26241

**TRANSMISSION**

**Removing the transmission, shift drum assembly, and shift forks**

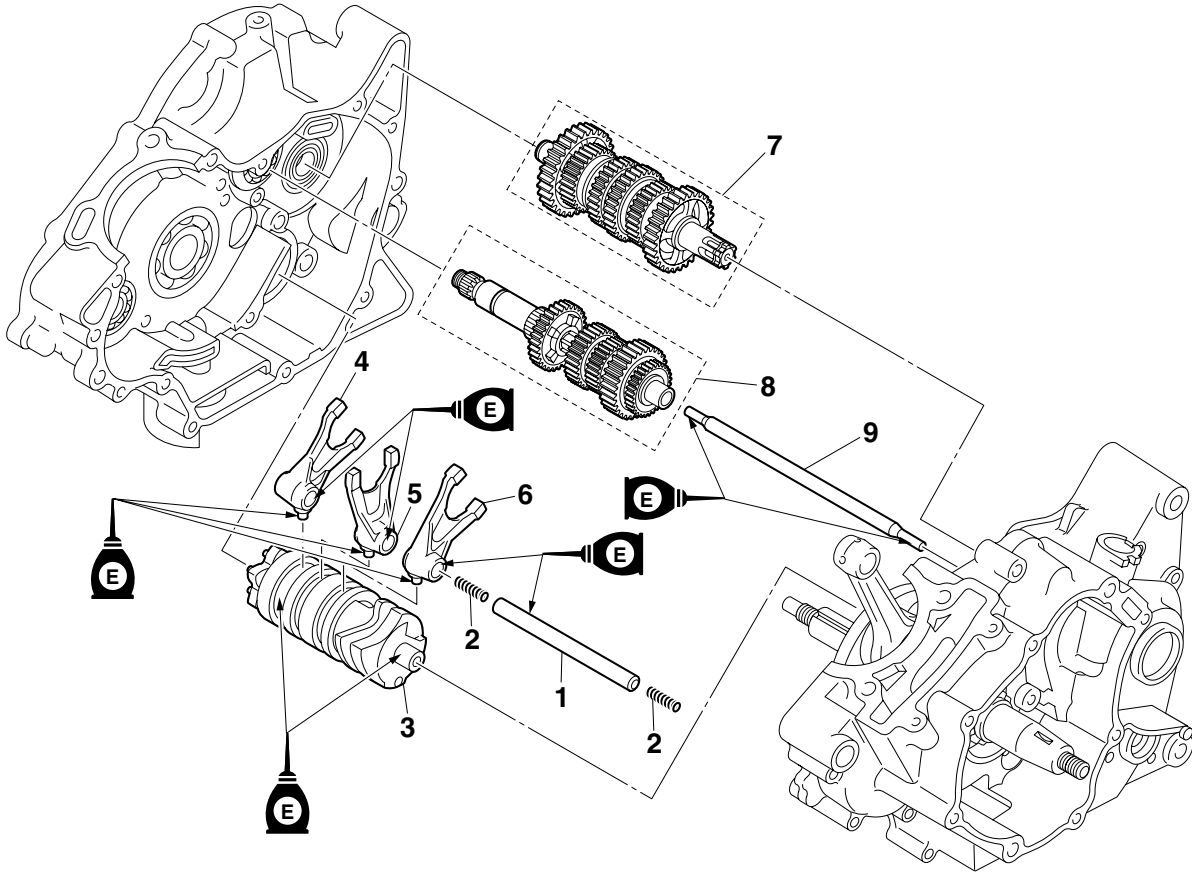

Order	Job/Parts to remove	Q'ty	Remarks
	Crankcase		Separate. Refer to "CRANKCASE" on page 5-56.
1	Shift fork guide bar	1	
2	Spring	2	
3	Shift drum assembly	1	
4	Shift fork-R	1	
5	Shift fork-C	1	
6	Shift fork-L	1	
7	Drive axle assembly	1	
8	Main axle assembly	1	
9	Long clutch push rod	1	
			For installation, reverse the removal procedure.

Disassembling the main axle

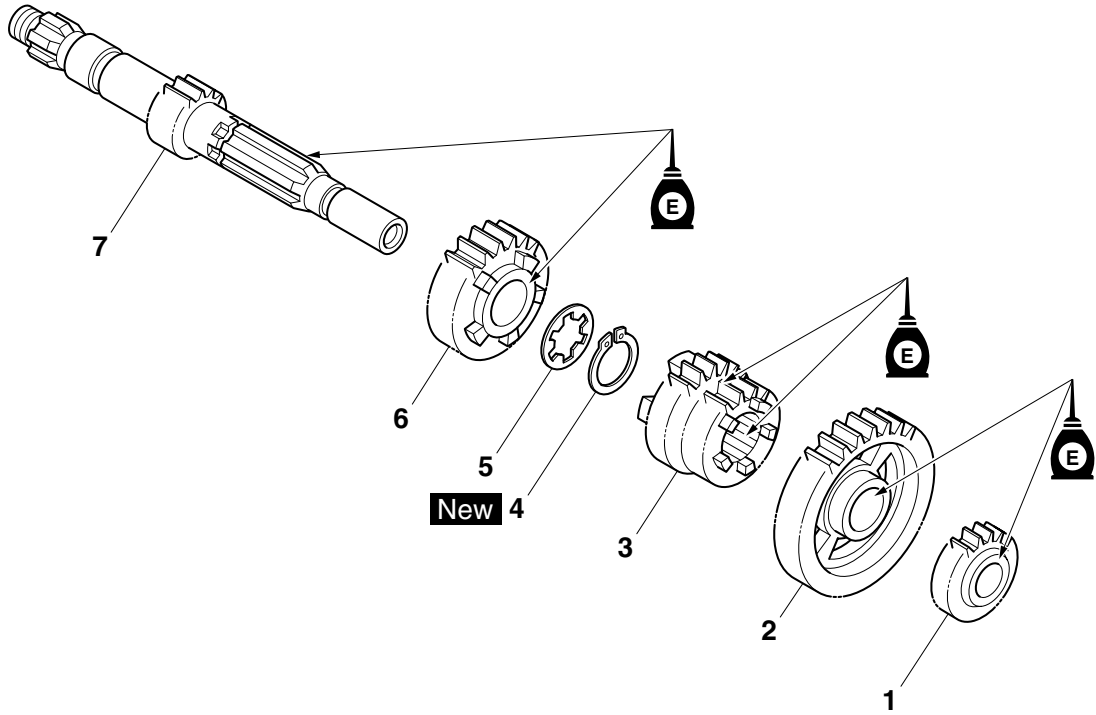

Order	Job/Parts to remove	Q'ty	Remarks
1	2nd pinion gear	1	
2	6th pinion gear	1	
3	3rd/4th pinion gear	1	
4	Circlip	1	
5	Toothed washer	1	
6	5th pinion gear	1	
7	Main axle/1st pinion gear	1	
			For assembly, reverse the disassembly procedure.

Disassembling the drive axle

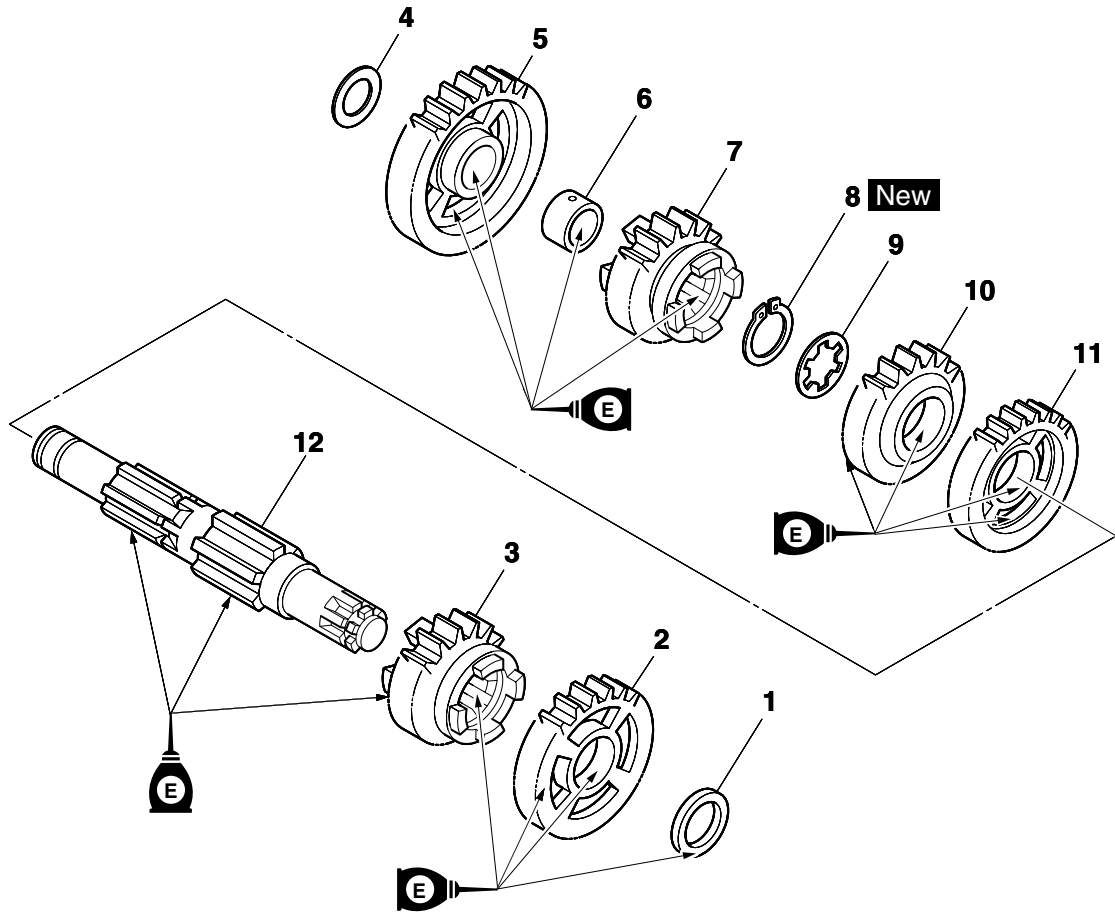

Order	Job/Parts to remove	Q'ty	Remarks
1	Washer	1	
2	2nd wheel gear	1	
3	6th wheel gear	1	
4	Washer	1	
5	1st wheel gear	1	
6	Spacer	1	
7	5th wheel gear	1	
8	Circlip	1	
9	Toothed washer	1	
10	4th wheel gear	1	
11	3rd wheel gear	1	
12	Drive axle	1	
			For assembly, reverse the disassembly procedure.

EAS26260

## CHECKING THE SHIFT FORKS

The following procedure applies to all of the shift forks.

1. Check:
  - Shift fork cam follower "1"
  - Shift fork pawl "2"
 Bends/damage/scoring/wear → Replace the shift fork.

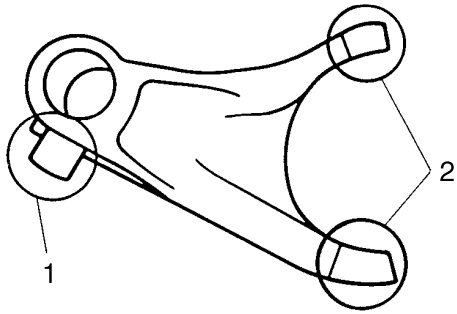

2. Check:
  - Shift fork guide bar
 Roll the shift fork guide bar on a flat surface.  
 Bends → Replace.

EWA12840

### **WARNING**

**Do not attempt to straighten a bent shift fork guide bar.**

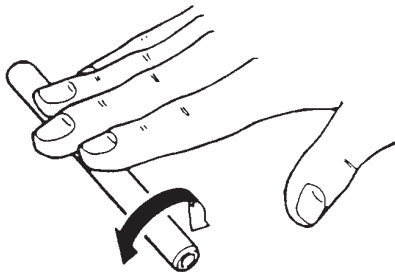

319-010

3. Check:
  - Shift fork movement (along the shift fork guide bar)
 Rough movement → Replace the shift forks and shift fork guide bar as a set.

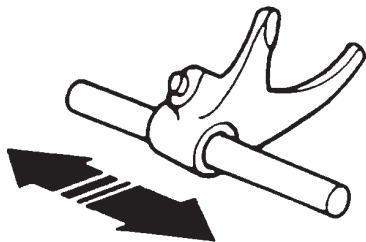

319-011

EAS26270

## CHECKING THE SHIFT DRUM ASSEMBLY

1. Check:
  - Shift drum groove  
Damage/scratches/wear → Replace the shift drum assembly.
  - Shift drum segment "1"
  - Shift drum bearing "2"
 Damage/wear → Replace the shift drum assembly.  
 Damage/pitting → Replace the shift drum assembly.

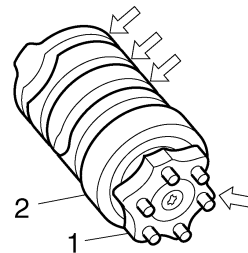

EAS26290

## CHECKING THE TRANSMISSION

1. Measure:
  - Main axle runout (with a centering device and dial gauge "1")
 Out of specification → Replace the main axle.



**Main axle runout limit**  
**0.08 mm (0.0032 in)**

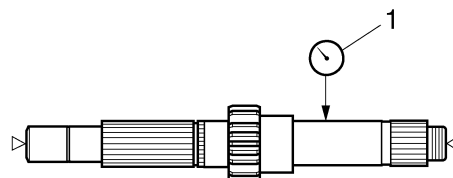

2. Measure:
  - Drive axle runout (with a centering device and dial gauge "1")
 Out of specification → Replace the drive axle.



**Drive axle runout limit**  
**0.08 mm (0.0032 in)**

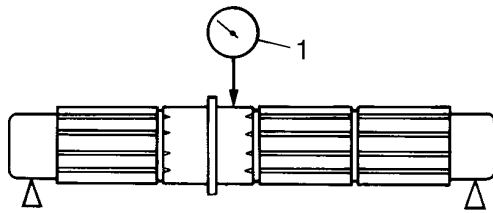

### 3. Check:

- Transmission gears  
Blue discoloration/pitting/wear → Replace the defective gear(s).
- Transmission gear dogs  
Cracks/damage/rounded edges → Replace the defective gear(s).

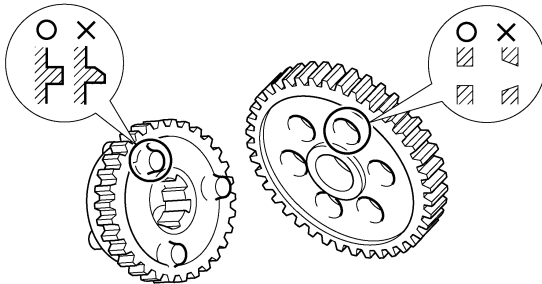

### 4. Check:

- Transmission gear engagement  
(each pinion gear to its respective wheel gear)  
Incorrect → Reassemble the transmission axle assemblies.

### 5. Check:

- Transmission gear movement  
Rough movement → Replace the defective part(s).

EAS22B1030

### CHECKING THE LONG CLUTCH PUSH ROD

#### 1. Check:

- Long clutch push rod  
Cracks/damage/wear → Replace the long clutch push rod.

#### 2. Measure:

- Long clutch push rod bending limit  
Out of specification → Replace the long clutch push rod.



**Long clutch push rod bending limit**  
0.500 mm (0.0197 in)

EAS29020

### ASSEMBLING THE MAIN AXLE AND DRIVE AXLE

#### 1. Install:

- Toothed washer "1"
- Circlip "2" **New**

#### TIP

- Be sure to install the circlip so that its sharp edge "a" is facing away from the toothed washer and gear.
- Be sure the circlip ends "b" are positioned at the axle spline groove "c".

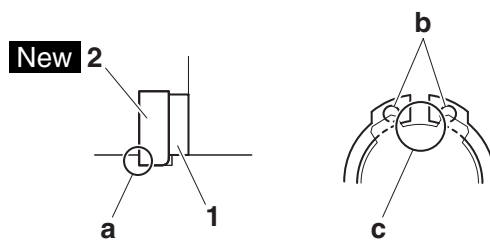

#### 2. Install:

- 2nd pinion gear "1"

#### TIP

Press the 2nd pinion gear into the main axle "2", as shown in the illustration.



**Installed depth "a"**  
106.85–107.05 mm (4.207–4.215 in)

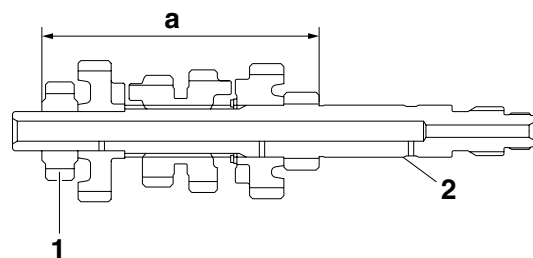

EAS26320

### INSTALLING THE SHIFT FORKS AND SHIFT DRUM ASSEMBLY

#### 1. Install:

- Shift fork-L "1"
- Shift fork-C "2"
- Shift fork-R "3"
- Shift drum assembly "4"
- Springs
- Shift fork guide bar "5"

**TIP**

The embossed marks on the shift forks should face towards the right side of the engine and be in the following sequence: "R", "C", "L".

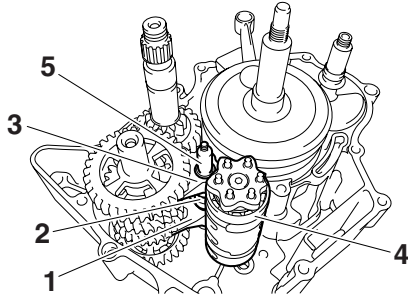

## 2. Check:

- Transmission  
Rough movement → Repair.

**TIP**

- Apply engine oil to each gear and bearing thoroughly.
- Before assembling the crankcase, make sure that the transmission is in neutral and that the gears turn freely.

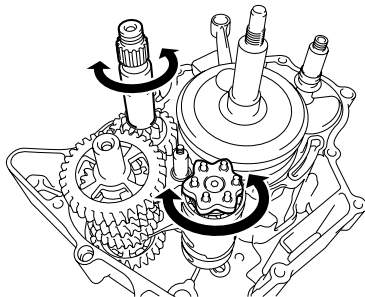





## COOLING SYSTEM

<b>RADIATOR</b> .....	6-1
CHECKING THE RADIATOR.....	6-3
INSTALLING THE RADIATOR.....	6-3
<b>THERMOSTAT</b> .....	6-4
CHECKING THE THERMOSTAT.....	6-5
INSTALLING THE THERMOSTAT.....	6-5
<b>WATER PUMP</b> .....	6-6
DISASSEMBLING THE WATER PUMP.....	6-8
CHECKING THE WATER PUMP .....	6-8
ASSEMBLING THE WATER PUMP.....	6-8
INSTALLING THE WATER PUMP .....	6-9

EAS26380

## RADIATOR

### Removing the radiator

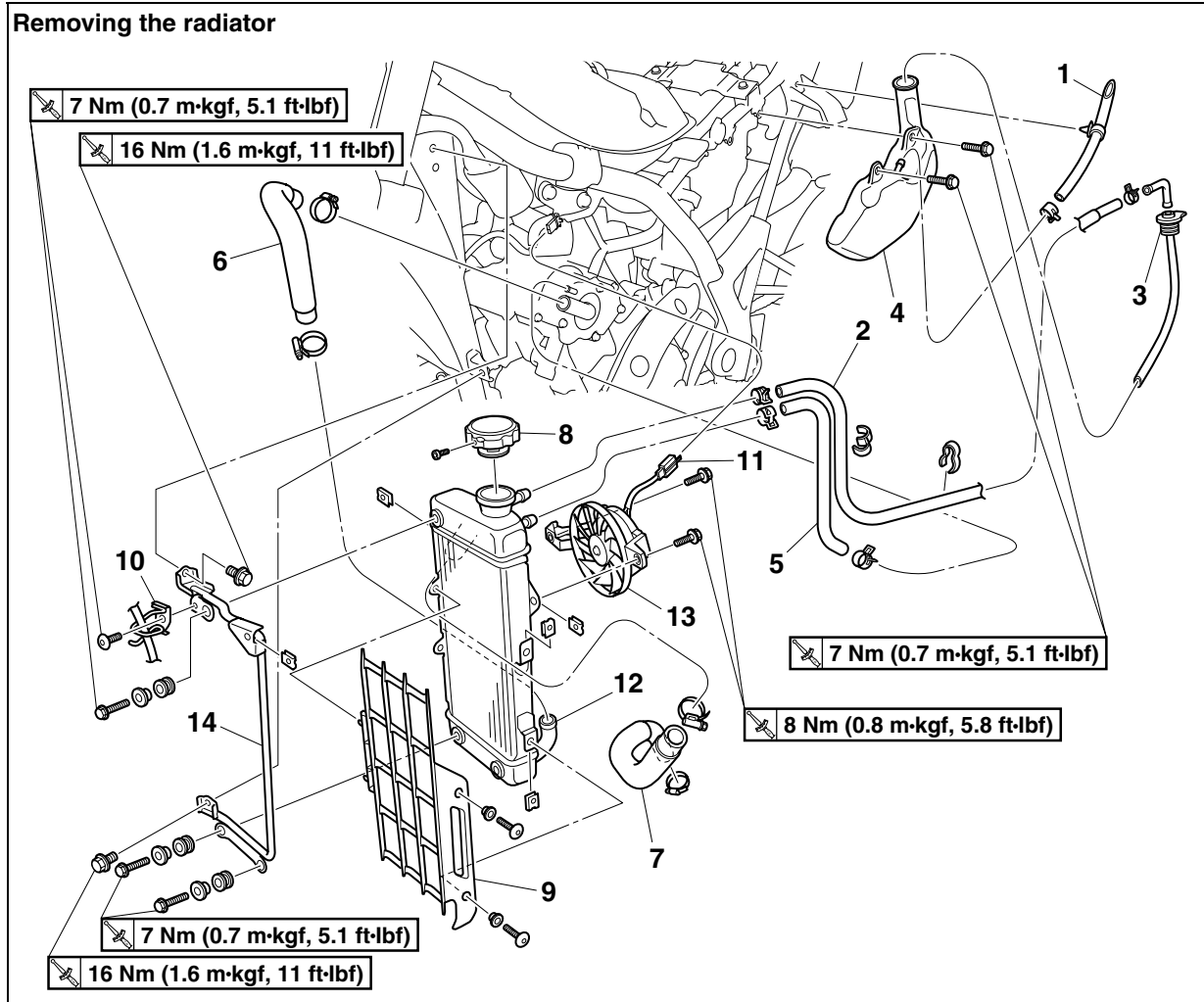

Order	Job/Parts to remove	Q'ty	Remarks
	Coolant		Drain. Refer to "CHANGING THE COOLANT" on page 3-15.
	Fuel tank cover assembly		Refer to "GENERAL CHASSIS" on page 4-1.
1	Coolant reservoir breather hose	1	
2	Coolant reservoir hose	1	
3	Coolant reservoir cap	1	
4	Coolant reservoir	1	
5	Water pump breather hose	1	
6	Radiator outlet hose	1	
7	Radiator inlet hose	1	
8	Radiator cap	1	
9	Radiator cover	1	
10	Clutch cable guide	1	
11	Radiator fan coupler	1	Disconnect.
12	Radiator	1	

Removing the radiator

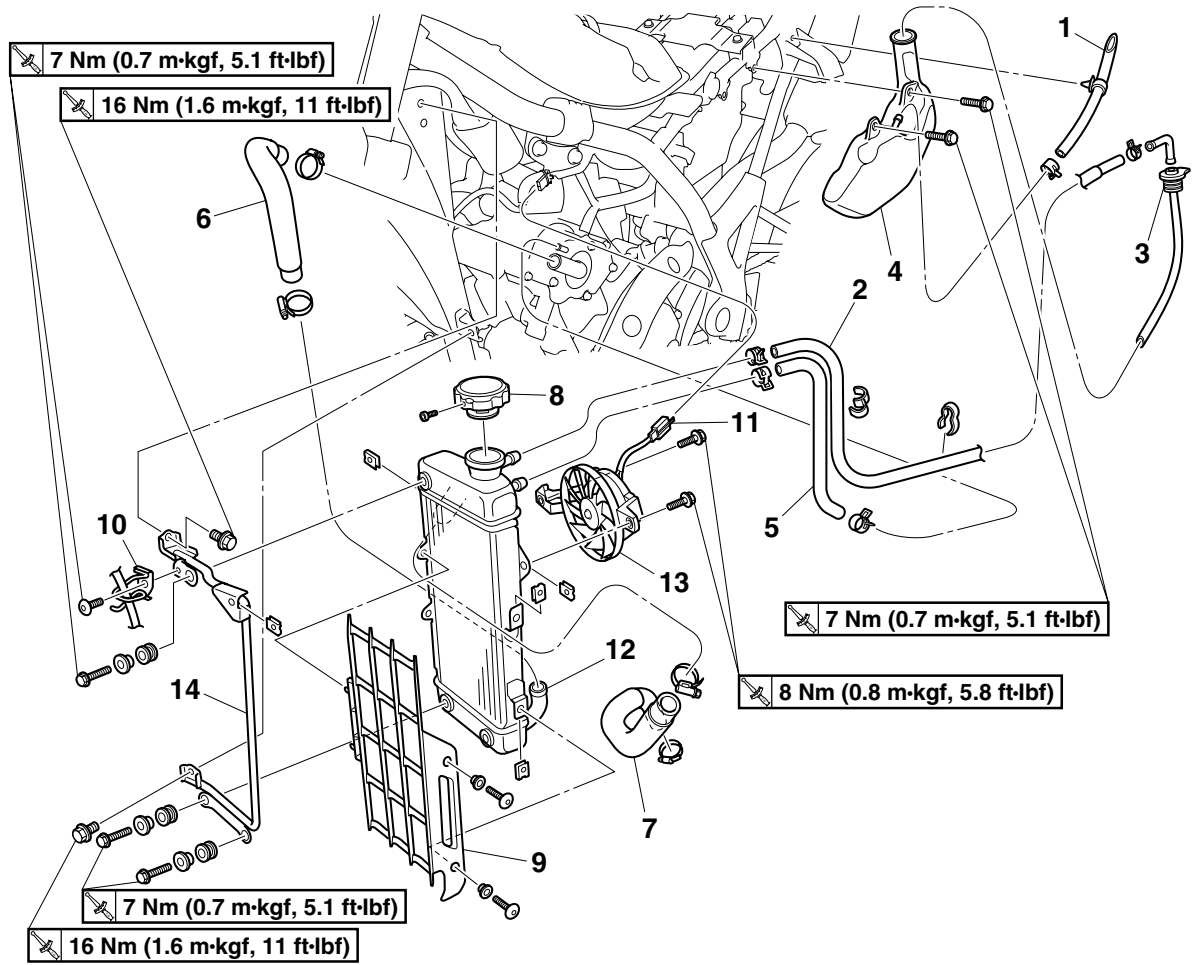

Order	Job/Parts to remove	Q'ty	Remarks
13	Radiator fan	1	
14	Radiator bracket	1	
			For installation, reverse the removal procedure.

EAS26390

## CHECKING THE RADIATOR

### 1. Check:

- Radiator fins  
Obstruction → Clean.  
Apply compressed air to the rear of the radiator.
- Damage → Repair or replace.

### TIP

Straighten any flattened fins with a thin, flat-head screwdriver.

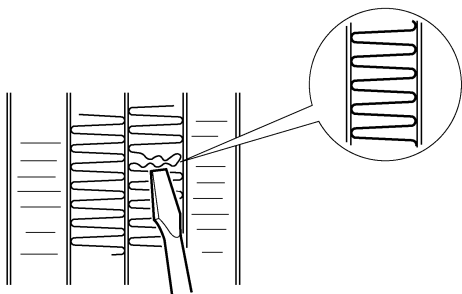

### 2. Check:

- Radiator hoses  
Cracks/damage → Replace.

### 3. Measure:

- Radiator cap opening pressure  
Below the specified pressure → Replace the radiator cap.



**Radiator cap opening pressure**  
108.0–137.4 kPa (1.08–1.37  
kgf/cm<sup>2</sup>, 15.7–19.9 psi)

- a. Install the radiator cap tester “1” and radiator cap tester adapter “2” to the radiator cap “3”.



**Radiator cap tester**  
90890-01325  
**Radiator pressure tester**  
YU-24460-01  
**Radiator cap tester adapter**  
90890-01352  
**Radiator pressure tester adapter**  
YU-33984

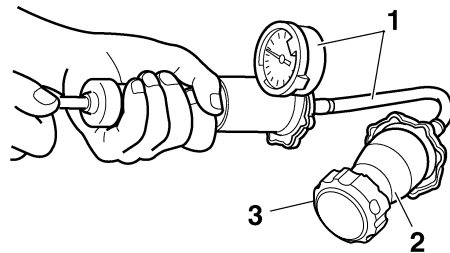

- b. Apply the specified pressure for ten seconds and make sure there is no drop in pressure.

### 4. Check:

- Radiator fan  
Damage → Replace.  
Malfunction → Check and repair.  
Refer to “COOLING SYSTEM” on page 8-25.

EAS26400

## INSTALLING THE RADIATOR

### 1. Fill:

- Cooling system  
(with the specified amount of the recommended coolant)  
Refer to “CHANGING THE COOLANT” on page 3-15.

### 2. Check:

- Cooling system  
Leaks → Repair or replace all faulty parts.

### 3. Measure:

- Radiator cap opening pressure  
Below the specified pressure → Replace the radiator cap.  
Refer to “CHECKING THE RADIATOR” on page 6-3.

EAS26440

**THERMOSTAT**

**Removing the thermostat**

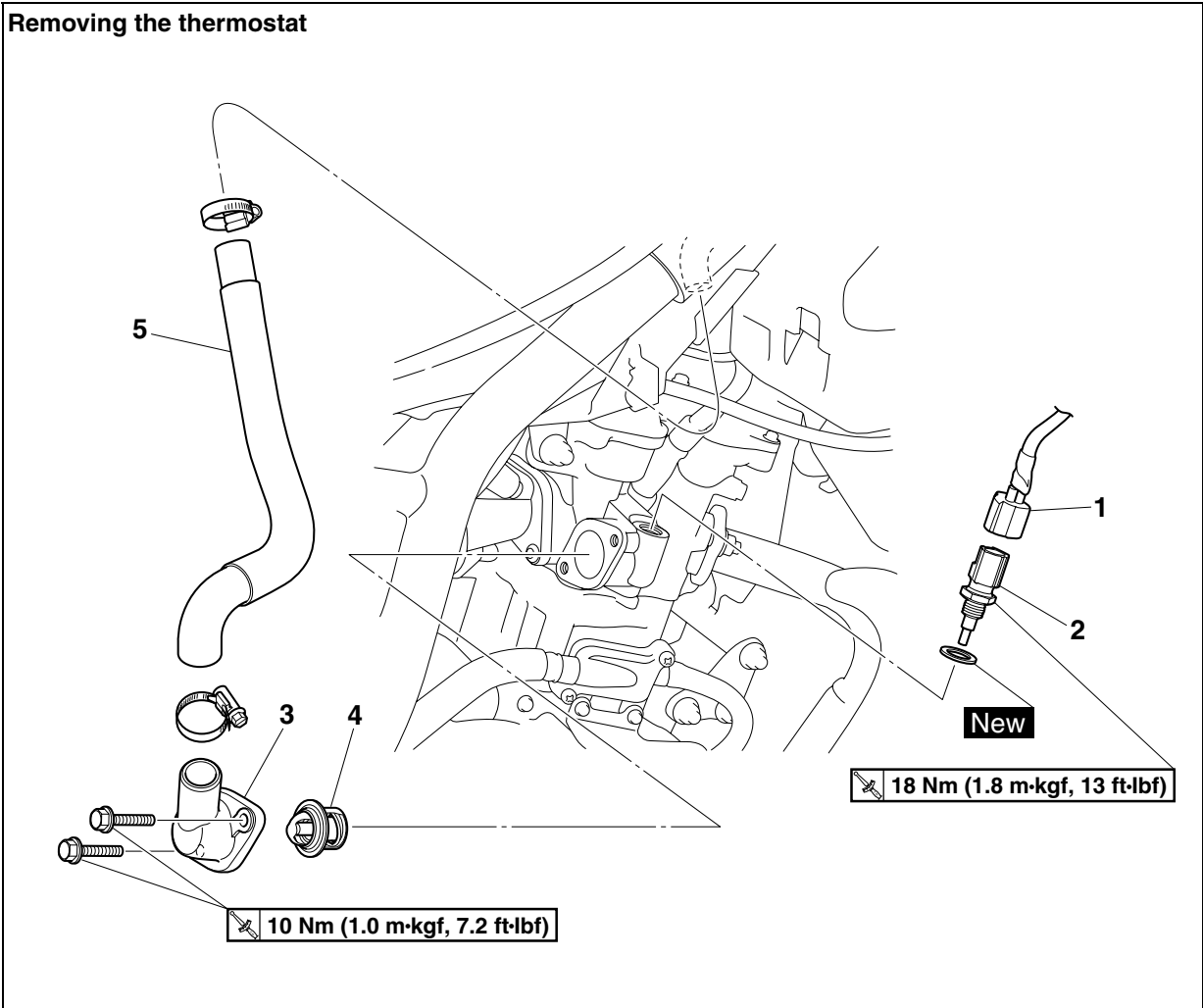

Order	Job/Parts to remove	Q'ty	Remarks
	Coolant		Drain. Refer to "CHANGING THE COOLANT" on page 3-15.
	Fuel tank cover assembly		Refer to "GENERAL CHASSIS" on page 4-1.
1	Coolant temperature sensor coupler	1	Disconnect.
2	Coolant temperature sensor	1	
3	Thermostat cover	1	
4	Thermostat	1	
5	Radiator inlet hose	1	
			For installation, reverse the removal procedure.

EAS26450

**CHECKING THE THERMOSTAT**

1. Check:
  - Thermostat  
Does not open at 80.5–83.5 °C (176.9–182.3 °F) → Replace.

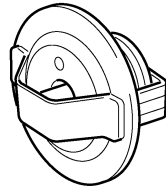

- a. Suspend the thermostat "1" in a container "2" filled with water.
- b. Slowly heat the water "3".
- c. Place a thermometer "4" in the water.
- d. While stirring the water, observe the thermostat and thermometer's indicated temperature.

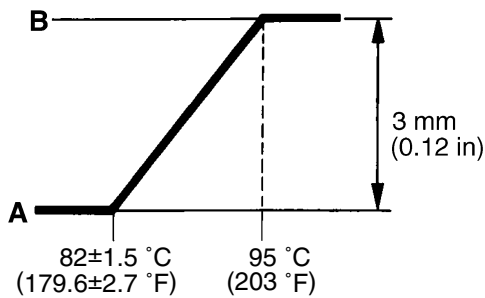
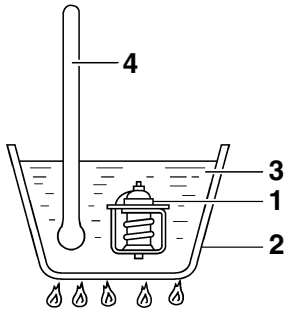

- A. Fully closed
- B. Fully open

**TIP**

If the accuracy of the thermostat is in doubt, replace it. A faulty thermostat could cause serious overheating or overcooling.

2. Check:
  - Thermostat cover  
Cracks/damage → Replace.
3. Check:
  - Radiator inlet hose  
Cracks/damage → Replace.

EAS26480

**INSTALLING THE THERMOSTAT**

1. Install:
  - Thermostat

**TIP**

Install the thermostat with its breather hole "a" facing up.



2. Install:
  - Copper washer **New**
  - Coolant temperature sensor



**Coolant temperature sensor**  
**18 Nm (1.8 m·kgf, 13 ft·lbf)**

ECA22B1012

**NOTICE**

Use extreme care when handling the coolant temperature sensor. Replace any part that was dropped or subjected to a strong impact.

3. Fill:
  - Cooling system  
(with the specified amount of the recommended coolant)  
Refer to "CHANGING THE COOLANT" on page 3-15.
4. Check:
  - Cooling system  
Leaks → Repair or replace all faulty parts.
5. Measure:
  - Radiator cap opening pressure  
Below the specified pressure → Replace the radiator cap.  
Refer to "CHECKING THE RADIATOR" on page 6-3.

EAS26500

**WATER PUMP**

**Removing the water pump**

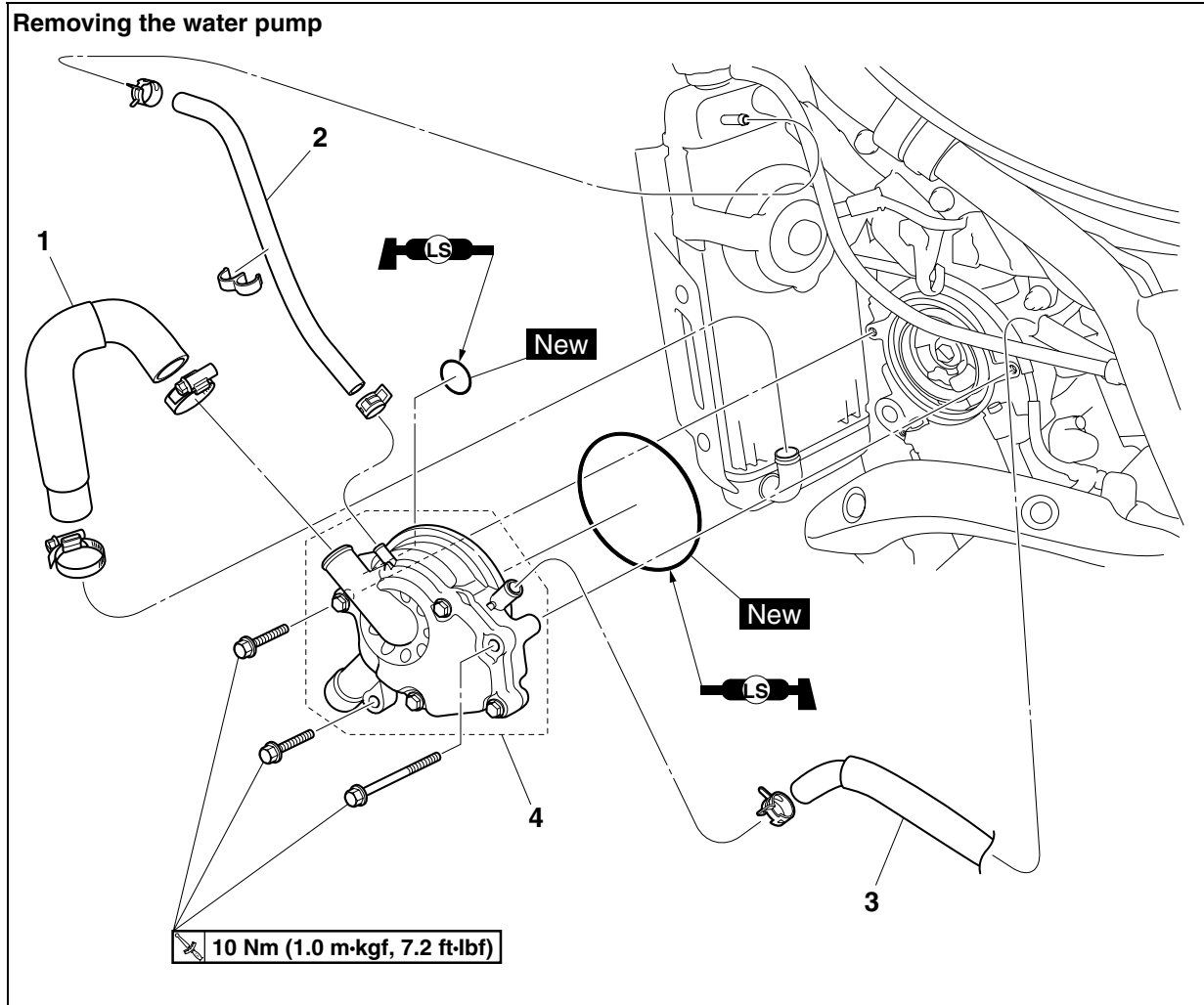

Order	Job/Parts to remove	Q'ty	Remarks
	Coolant		Drain. Refer to "CHANGING THE COOLANT" on page 3-15.
	Fuel tank cover assembly		Refer to "GENERAL CHASSIS" on page 4-1.
1	Radiator outlet hose	1	
2	Water pump breather hose	1	
3	Cylinder head breather hose	1	Disconnect.
4	Water pump assembly	1	
			For installation, reverse the removal procedure.

Disassembling the water pump

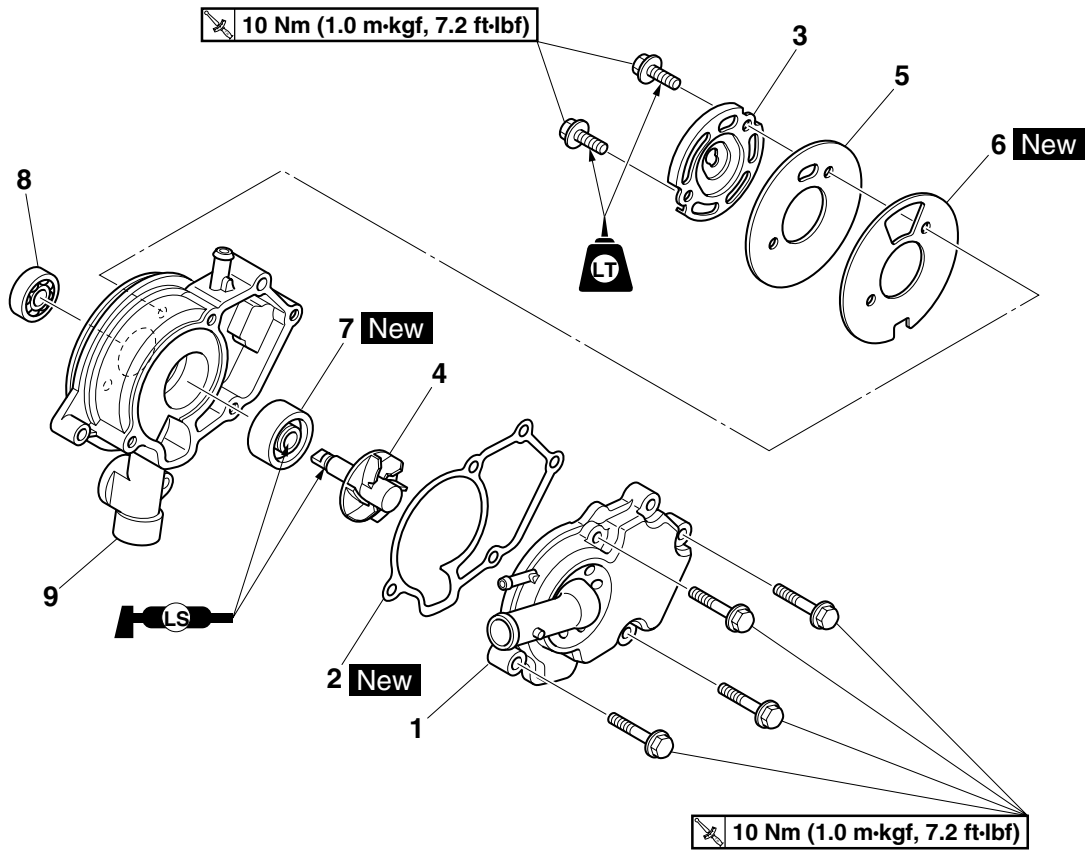

Order	Job/Parts to remove	Q'ty	Remarks
1	Water pump housing cover	1	
2	Water pump housing cover gasket	1	
3	Impeller shaft retainer	1	
4	Impeller shaft	1	
5	Water pump housing plate	1	
6	Water pump housing gasket	1	
7	Water pump seal	1	
8	Bearing	1	
9	Water pump housing	1	
			For assembly, reverse the disassembly procedure.



EAS26510

## DISASSEMBLING THE WATER PUMP

1. Remove:
  - Water pump seal "1"

### TIP

Remove the water pump seal from the inside of the water pump housing "2".

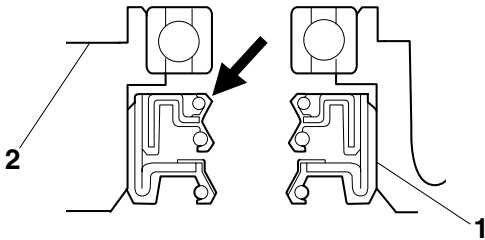

2. Remove:
  - Bearing "1"

### TIP

Remove the bearing from the outside of the water pump housing "2".

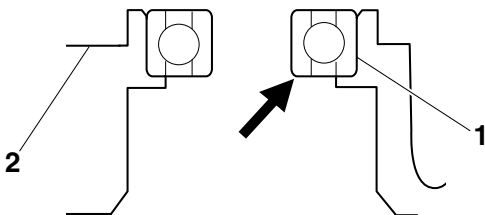

EAS26530

## CHECKING THE WATER PUMP

1. Check:
  - Water pump housing cover
  - Water pump housing  
Cracks/damage → Replace.
  - Impeller shaft  
Cracks/damage/wear → Replace.
  - Bearing  
Rough movement → Replace.
  - Radiator outlet hose  
Cracks/damage → Replace.

EAS26560

## ASSEMBLING THE WATER PUMP

1. Install:
  - Water pump seal "1" **New**  
(into the water pump housing "2")

ECA14080

## NOTICE

Never lubricate the water pump seal surface with oil or grease.

### TIP

Install the water pump seal with the special tools to the specified depth as shown in the illustration.



**Mechanical seal installer**  
90890-04145  
**Middle driven shaft bearing driver**  
90890-04058  
**Bearing driver 40 mm**  
YM-04058

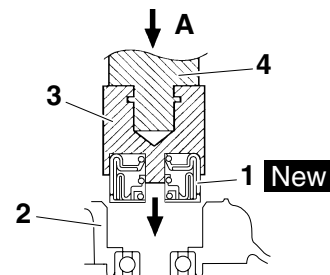

- A. Push down
3. Mechanical seal installer
4. Middle driven shaft bearing driver

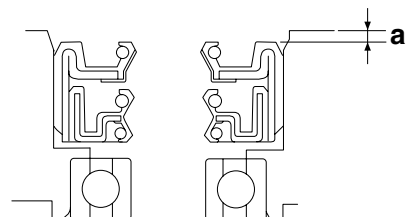

a. 0–0.5 mm (0–0.02 in)

2. Lubricate:
  - Water pump seal lip



**Recommended lubricant**  
**Lithium-soap-based grease**

3. Install:
  - Water pump housing gasket "1" **New**
  - Water pump housing plate "2"
  - Impeller shaft

- Impeller shaft retainer “3”



**Impeller shaft retainer bolt**  
**10 Nm (1.0 m·kgf, 7.2 ft·lbf)**  
**LOCTITE®**

#### TIP

- Before installing the impeller shaft retainer, lubricate the slit on the impeller shaft end with a thin coat of lithium-soap-based grease.
- Install the water pump housing gasket, water pump housing plate, and impeller shaft retainer as shown in the illustration.
- After installation, check that the impeller shaft rotates smoothly.

#### 3. Check:

- Cooling system  
 Leaks → Repair or replace all faulty parts.

#### 4. Measure:

- Radiator cap opening pressure  
 Below the specified pressure → Replace the radiator cap.  
 Refer to “CHECKING THE RADIATOR” on page 6-3.

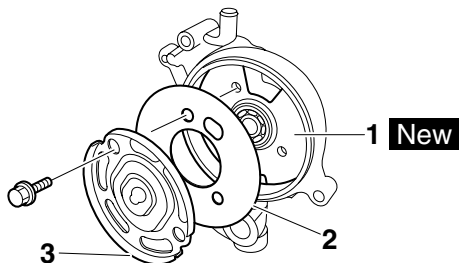

EAS26580

#### INSTALLING THE WATER PUMP

##### 1. Install:

- Water pump assembly “1”
- O-rings “2” **New**

#### TIP

- Align the projection “a” on the impeller shaft with the slit “b” on the camshaft sprocket bolt.
- Lubricate the O-rings with a thin coat of lithium-soap-based grease.

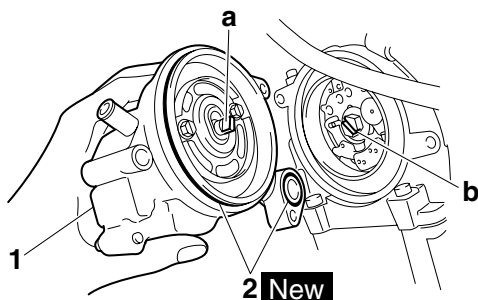

##### 2. Fill:

- Cooling system  
 (with the specified amount of the recommended coolant)  
 Refer to “CHANGING THE COOLANT” on page 3-15.

## FUEL SYSTEM

<b>FUEL TANK</b> .....	7-1
REMOVING THE FUEL TANK.....	7-2
REMOVING THE FUEL PUMP.....	7-2
CHECKING THE FUEL PUMP BODY.....	7-2
INSTALLING THE FUEL PUMP.....	7-2
INSTALLING THE FUEL TANK.....	7-3
CHECKING THE FUEL PRESSURE.....	7-3
<b>THROTTLE BODY</b> .....	7-5
REMOVING THE THROTTLE BODY.....	7-7
CHECKING THE FUEL INJECTOR.....	7-7
CHECKING THE THROTTLE BODY.....	7-7
INSTALLING THE THROTTLE BODY.....	7-7
<b>AIR INDUCTION SYSTEM</b> .....	7-9
CHECKING THE AIR INDUCTION SYSTEM.....	7-12

EAS26620

## FUEL TANK

### Removing the fuel tank

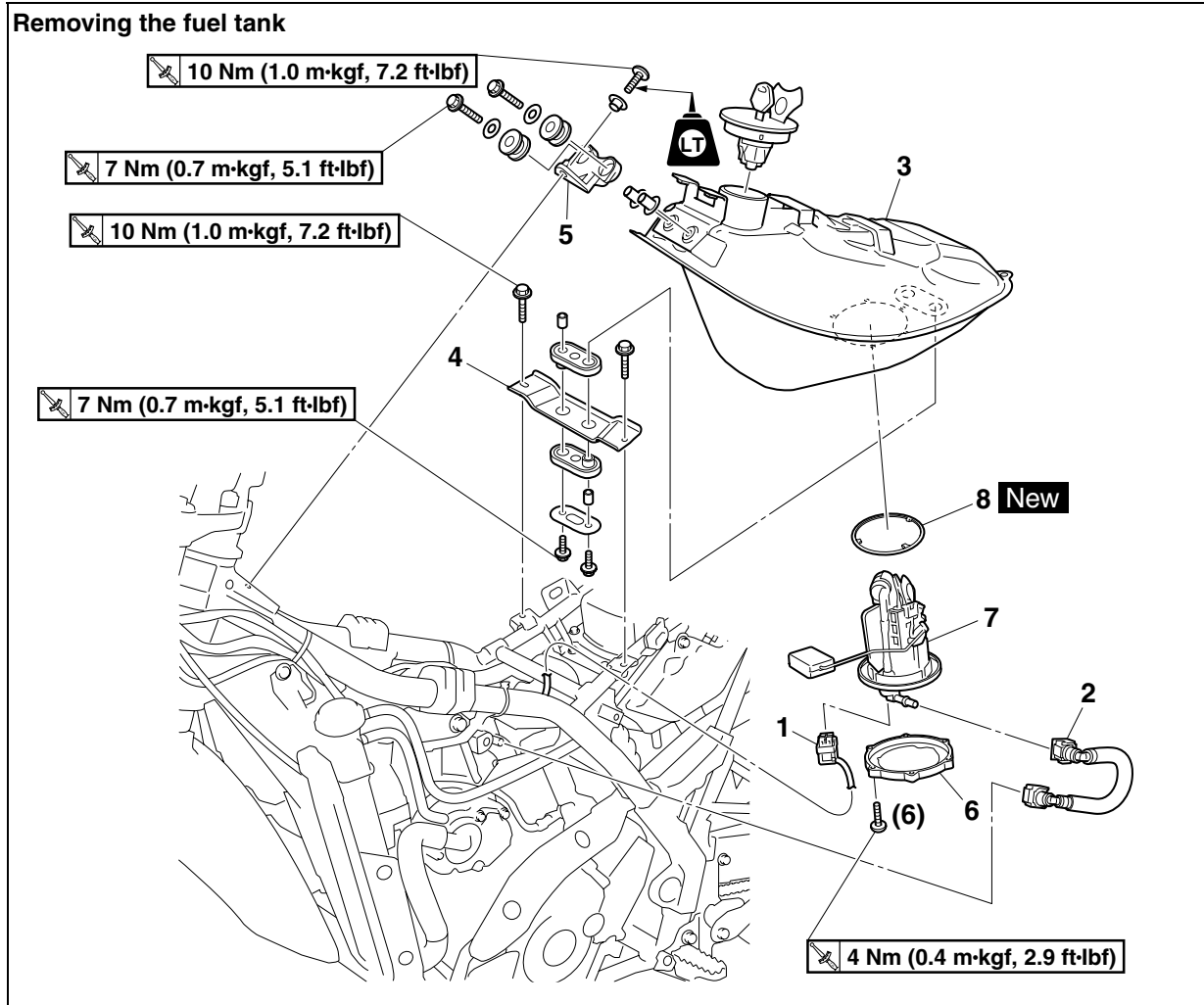

Order	Job/Parts to remove	Q'ty	Remarks
	Fuel tank cover assembly		Refer to "GENERAL CHASSIS" on page 4-1.
1	Fuel pump coupler	1	Disconnect.
2	Fuel hose	1	
3	Fuel tank	1	
4	Fuel tank rear bracket	1	
5	Fuel tank front bracket	1	
6	Fuel pump bracket	1	
7	Fuel pump	1	
8	Fuel pump gasket	1	
			For installation, reverse the removal procedure.

EAS26630

## REMOVING THE FUEL TANK

1. Extract the fuel in the fuel tank through the fuel tank filler hole with a pump.
2. Disconnect:
  - Fuel hose

EWA22B1009

### **WARNING**

Cover fuel hose connections with a cloth when disconnecting them. Residual pressure in the fuel line could cause fuel to spurt out when disconnecting a hose.

ECA22B1026

### **NOTICE**

Although the fuel has been removed from the fuel tank, be careful when removing the fuel hose, since there may be fuel remaining in it.

### **TIP**

- To remove the fuel hose from the fuel pump or fuel injector, slide the fuel hose connector cover "1" on the end of the hose in the direction of the arrow shown, press the two buttons "2" on the sides of the connector, and then remove the hose.
- Remove the fuel hose manually without using any tools.
- Before removing the hose, place a few rags in the area under where it will be removed.

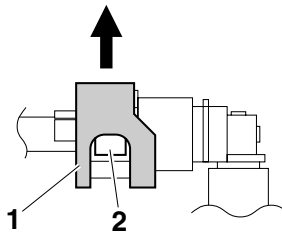

3. Remove:
  - Fuel tank

### **TIP**

Do not set the fuel tank down on the installation surface of the fuel pump. Be sure to lean the fuel tank in an upright position.

EAS26640

## REMOVING THE FUEL PUMP

1. Remove:
  - Fuel pump

ECA14720

### **NOTICE**

- Do not drop the fuel pump or give it a strong shock.
- Do not touch the base section of the fuel sender.

EAS26670

## CHECKING THE FUEL PUMP BODY

1. Check:
  - Fuel pump body  
Obstruction → Clean.  
Cracks/damage → Replace fuel pump assembly.
2. Check:
  - Gasket  
Tears/fatigue/cracks → Replace.

EAS26700

## INSTALLING THE FUEL PUMP

1. Install:
  - Fuel pump gasket **New**
  - Fuel pump
  - Fuel pump bracket



**Fuel pump bolt**  
4 Nm (0.4 m·kgf, 2.9 ft·lbf)

### **TIP**

- Do not damage the installation surfaces of the fuel tank when installing the fuel pump.
- Always use a new fuel pump gasket.
- Install the fuel pump in the direction shown in the illustration.
- Align the projection "a" on the fuel pump with the slot in the fuel pump bracket.
- Align the punch mark "b" on the fuel tank with the slot in the fuel pump bracket.
- Tighten the fuel pump bolts in the proper tightening sequence as shown.

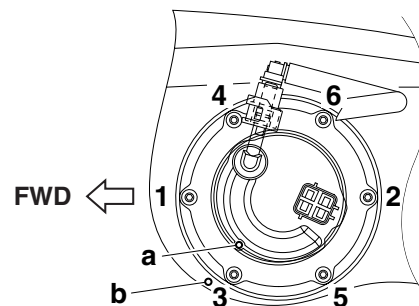

EAS22B1034

## INSTALLING THE FUEL TANK

### 1. Install:

- Fuel tank rear bracket "1"

### TIP

Make sure that the hole "a" in the fuel tank rear bracket is on the left side of the vehicle.

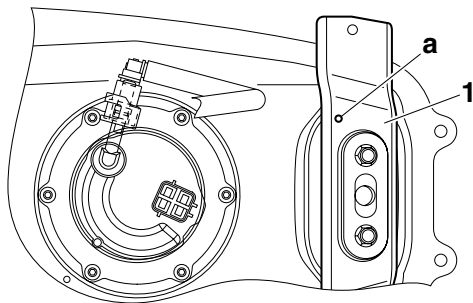

### 2. Install:

- Fuel hose

EWA22B1011

### NOTICE

When installing the fuel hose, make sure that it is securely connected, and that the fuel hose connector cover on the fuel hose is in the correct position; otherwise the fuel hose will not be properly installed.

### TIP

- Connect the orange connector "1" of the fuel hose to the fuel pump and the black connector "2" to the fuel injector.
- Install the fuel hose securely onto the fuel pump and fuel injector until a distinct "click" is heard.
- To install the fuel hose onto the fuel pump or fuel injector, slide the fuel hose connector cover "3" on the end of the hose in the direction of the arrow shown.

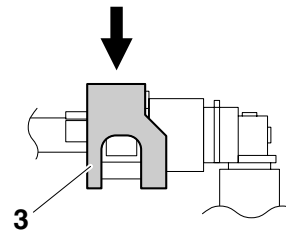
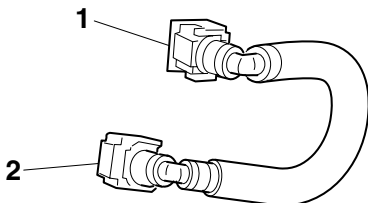

EAS27010

## CHECKING THE FUEL PRESSURE

### 1. Check:

- Fuel pressure

- Disconnect the fuel hose "1" from the fuel pump.

EWA22B1009

### WARNING

Cover fuel hose connections with a cloth when disconnecting them. Residual pressure in the fuel line could cause fuel to spurt out when disconnecting a hose.

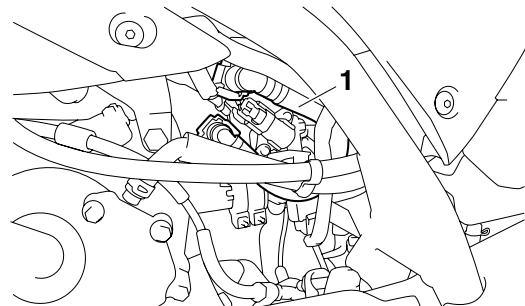

- Connect the fuel pressure adapter "2" between the fuel hose and fuel pump.
- Connect the pressure gauge "3" to the fuel pressure adapter.

EWA22B1016

### WARNING

Do not allow the fuel hose "1" and the fuel pressure gauge hose to come into contact with the exhaust pipe.



Pressure gauge  
90890-03153  
YU-03153  
Fuel pressure adapter  
90890-03186

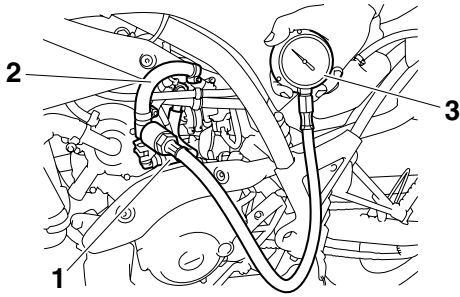

- d. Start the engine.
- e. Measure the fuel pressure.



**Output pressure**  
**250.0 kPa (2.50 kgf/cm<sup>2</sup>, 36.3 psi)**

Out of specification → Replace the fuel pump.



EAS26970

## THROTTLE BODY

### Removing the throttle body

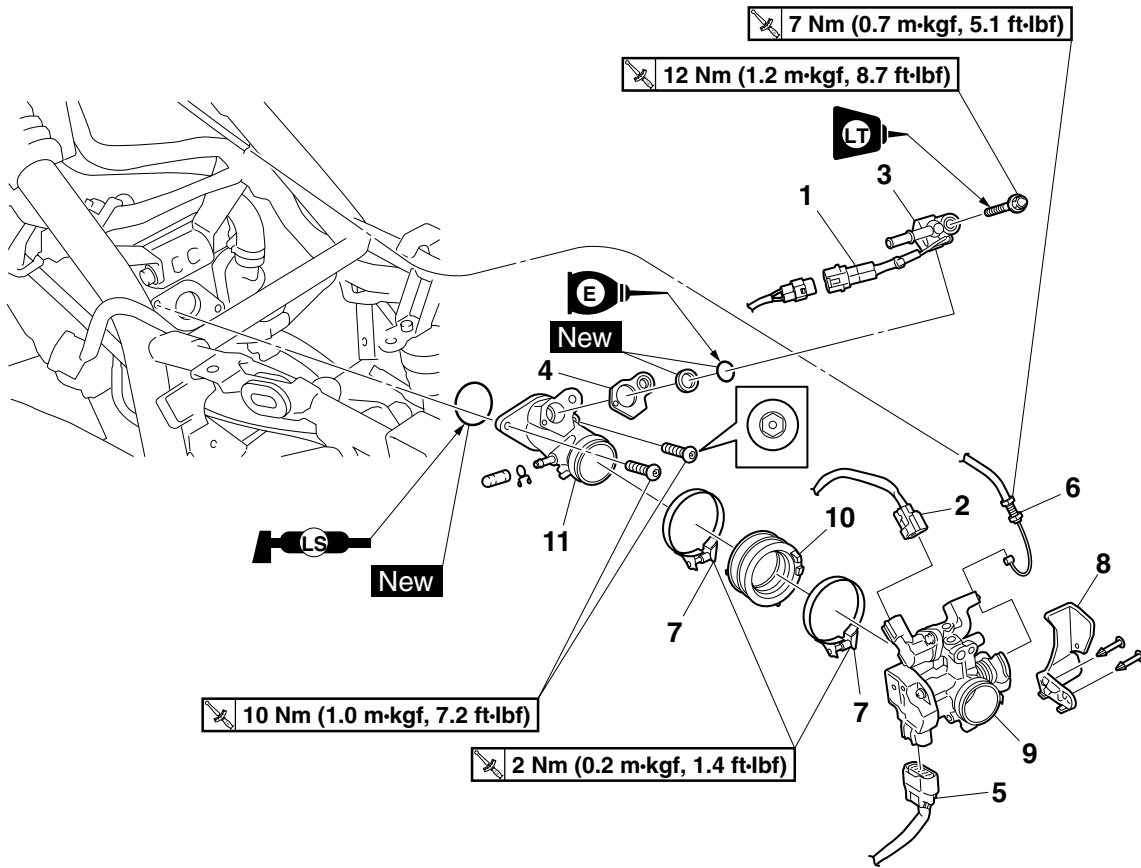

Order	Job/Parts to remove	Q'ty	Remarks
	Fuel tank		Refer to "FUEL TANK" on page 7-1.
	Air filter case		Refer to "GENERAL CHASSIS" on page 4-1.
1	Fuel injector coupler	1	Disconnect.
2	FID (fast idle solenoid) coupler	1	Disconnect.
3	Fuel injector	1	
4	Fuel injector gasket	1	
5	Throttle body sensor assembly coupler	1	Disconnect.
6	Throttle cable	1	Disconnect.
7	Throttle body joint clamp screw	2	Loosen.
8	Throttle body cover	1	WR125R
9	Throttle body	1	ECA22B1013 <b>NOTICE</b> The throttle body should not be disassembled.
10	Throttle body joint	1	



Removing the throttle body

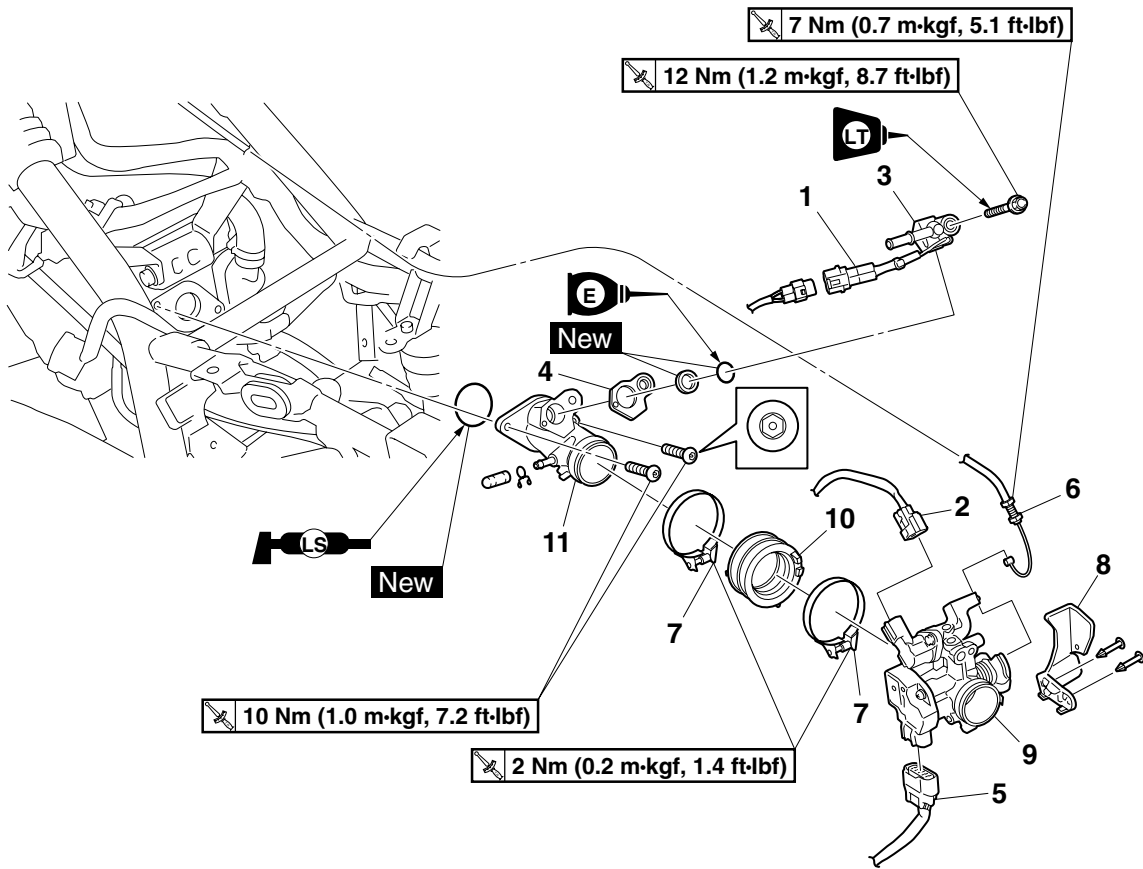

Order	Job/Parts to remove	Q'ty	Remarks
11	Intake manifold	1	
			For installation, reverse the removal procedure.





EAS27040

AIR INDUCTION SYSTEM

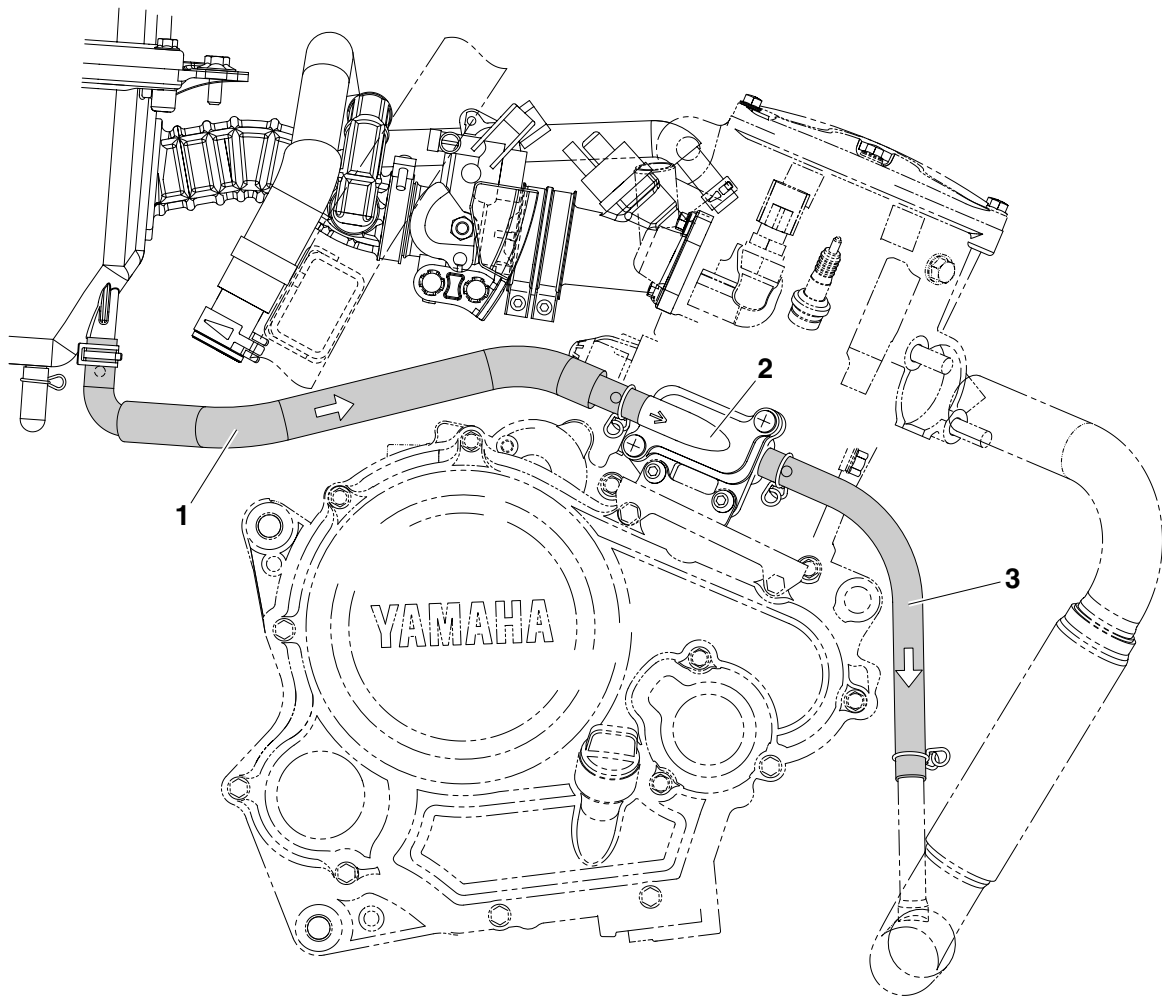

1. Air induction system hose (air filter case to reed valve assembly)
2. Air induction system reed valve assembly
3. Air induction system hose (reed valve assembly to exhaust pipe)

Removing the air induction system reed valve assembly

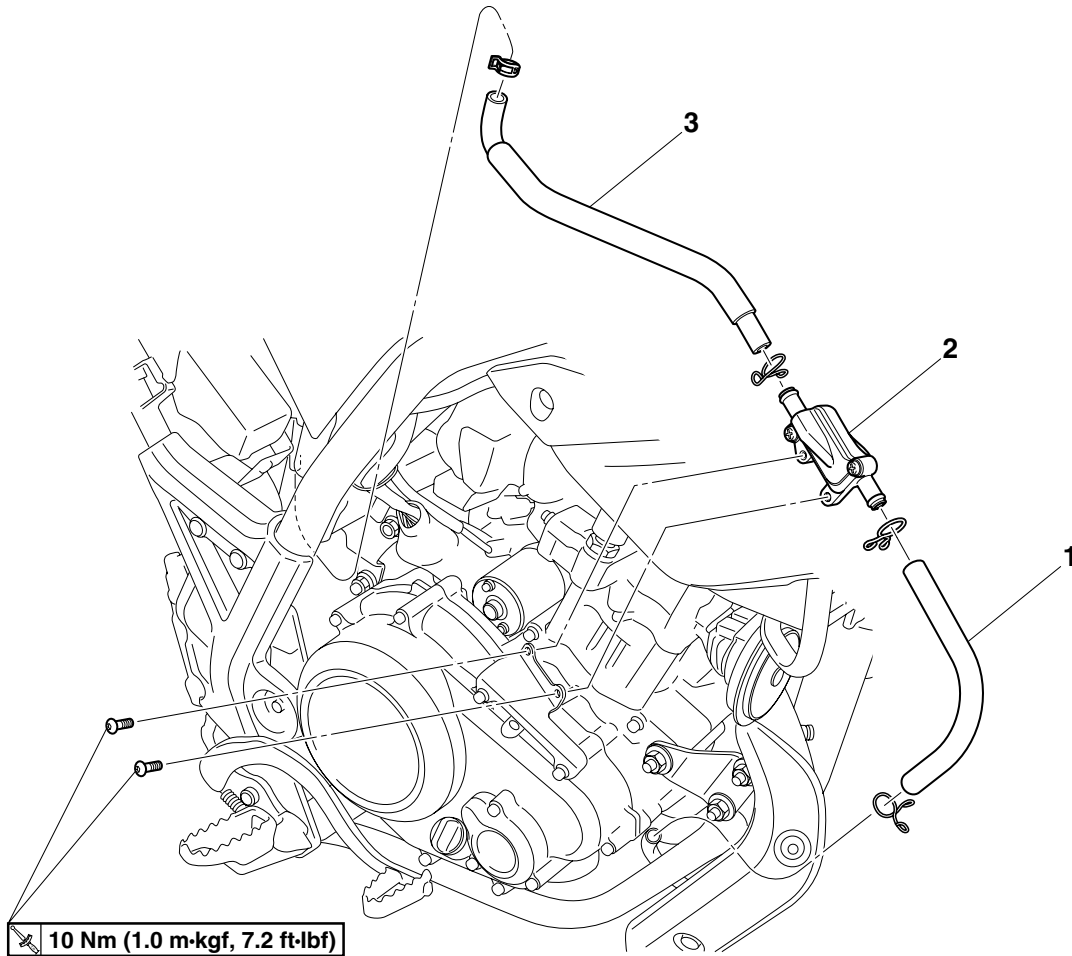

Order	Job/Parts to remove	Q'ty	Remarks
1	Air induction system hose (reed valve assembly to exhaust pipe)	1	
2	Air induction system reed valve assembly	1	
3	Air induction system hose (air filter case to reed valve assembly)	1	
			For installation, reverse the removal procedure.







---

## ELECTRICAL SYSTEM

<b>IGNITION SYSTEM</b> .....	8-1
CIRCUIT DIAGRAM .....	8-1
TROUBLESHOOTING .....	8-3
<b>ELECTRIC STARTING SYSTEM</b> .....	8-5
CIRCUIT DIAGRAM .....	8-5
STARTING CIRCUIT CUT-OFF SYSTEM OPERATION .....	8-7
TROUBLESHOOTING .....	8-8
<b>CHARGING SYSTEM</b> .....	8-11
CIRCUIT DIAGRAM .....	8-11
TROUBLESHOOTING .....	8-13
<b>LIGHTING SYSTEM</b> .....	8-15
CIRCUIT DIAGRAM .....	8-15
TROUBLESHOOTING .....	8-17
<b>SIGNALING SYSTEM</b> .....	8-19
CIRCUIT DIAGRAM .....	8-19
TROUBLESHOOTING .....	8-21
<b>COOLING SYSTEM</b> .....	8-25
CIRCUIT DIAGRAM .....	8-25
TROUBLESHOOTING .....	8-27
<b>FUEL INJECTION SYSTEM</b> .....	8-29
CIRCUIT DIAGRAM .....	8-29
ECU SELF-DIAGNOSTIC FUNCTION .....	8-31
SELF-DIAGNOSTIC FUNCTION TABLE .....	8-32
TROUBLESHOOTING METHOD .....	8-34
DIAGNOSTIC MODE .....	8-34
TROUBLESHOOTING DETAILS .....	8-42
<b>FUEL PUMP SYSTEM</b> .....	8-55
CIRCUIT DIAGRAM .....	8-55
TROUBLESHOOTING .....	8-57

<b>ELECTRICAL COMPONENTS</b> .....	8-59
CHECKING THE SWITCHES .....	8-61
CHECKING THE BULBS AND BULB SOCKETS .....	8-64
CHECKING THE FUSES .....	8-65
CHECKING AND CHARGING THE BATTERY .....	8-65
CHECKING THE RELAYS .....	8-67
CHECKING THE TURN SIGNAL RELAY .....	8-68
CHECKING THE DIODE .....	8-69
CHECKING THE SPARK PLUG CAP .....	8-69
CHECKING THE IGNITION COIL .....	8-70
CHECKING THE IGNITION SPARK GAP .....	8-70
CHECKING THE CRANKSHAFT POSITION SENSOR.....	8-71
CHECKING THE LEAN ANGLE SENSOR.....	8-71
CHECKING THE STARTER MOTOR OPERATION .....	8-72
CHECKING THE STATOR COIL .....	8-72
CHECKING THE RECTIFIER/REGULATOR .....	8-72
CHECKING THE HORN.....	8-73
CHECKING THE FUEL SENDER .....	8-73
CHECKING THE SPEED SENSOR .....	8-74
CHECKING THE RADIATOR FAN MOTOR .....	8-74
CHECKING THE COOLANT TEMPERATURE SENSOR.....	8-75
CHECKING THE THROTTLE BODY SENSOR ASSEMBLY .....	8-75
CHECKING THE FID (FAST IDLE SOLENOID) .....	8-77

YamahaR125.COM

---

EAS27090

IGNITION SYSTEM

EAS27100

CIRCUIT DIAGRAM

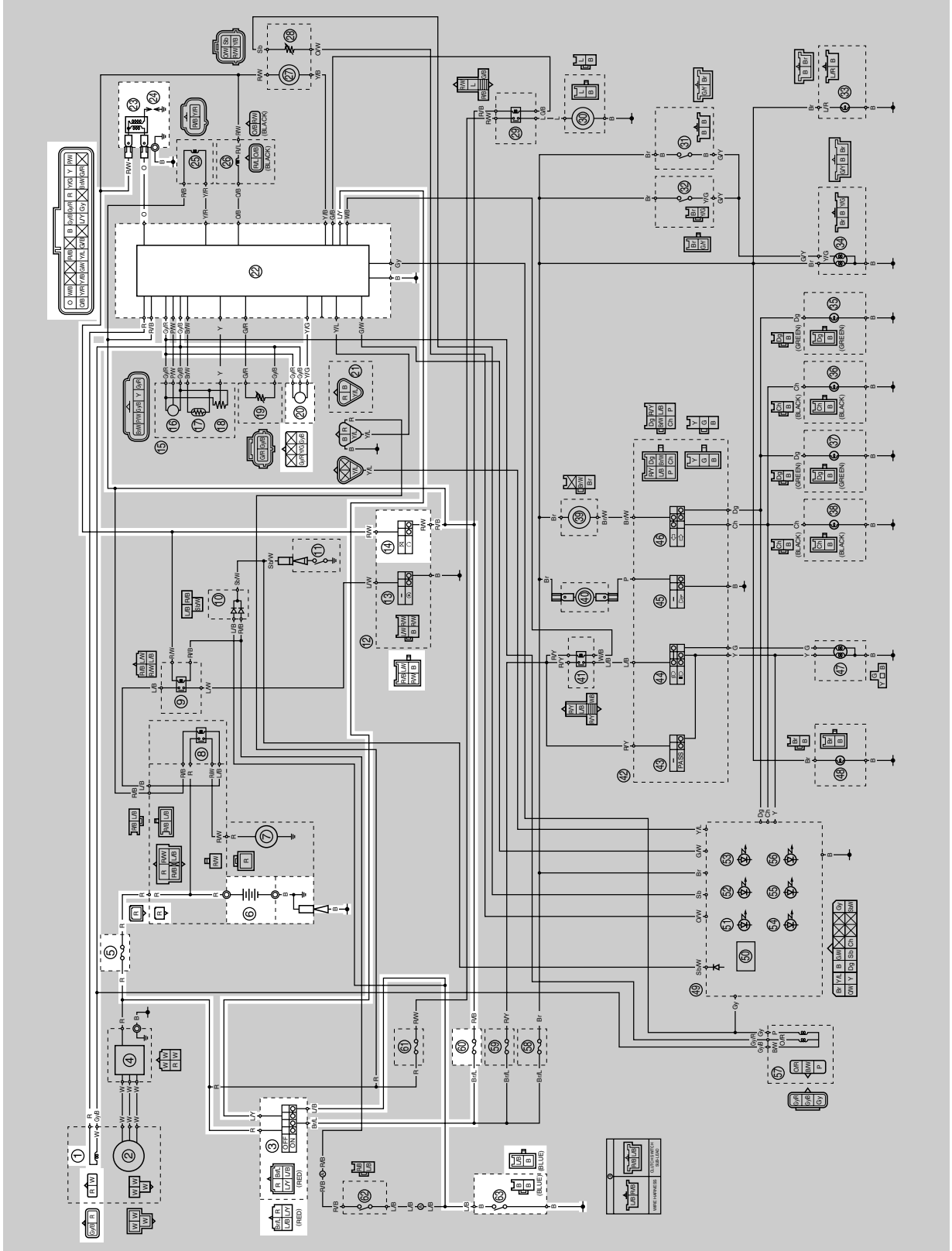

- 1. Crankshaft position sensor
- 3. Main switch
- 5. Main fuse
- 6. Battery
- 14. Engine stop switch
- 20. Lean angle sensor
- 22. ECU (engine control unit)
- 23. Ignition coil
- 24. Spark plug
- 60. Ignition fuse
- 63. Sidestand switch

EAS27120

## TROUBLESHOOTING

The ignition system fails to operate (no spark or intermittent spark).

### TIP

• Before troubleshooting, remove the following part(s):

1. Battery cover
2. Rear fender
3. Fuel tank

<p>1. Check the fuses. (Main and ignition) Refer to "CHECKING THE FUSES" on page 8-65.</p>	NG →	<p>Replace the fuse(s).</p>
OK ↓		
<p>2. Check the battery. Refer to "CHECKING AND CHARGING THE BATTERY" on page 8-65.</p>	NG →	<ul style="list-style-type: none"> <li>• Refill battery fluid.</li> <li>• Clean the battery terminals.</li> <li>• Recharge or replace the battery.</li> </ul>
OK ↓		
<p>3. Check the spark plug. Refer to "CHECKING THE SPARK PLUG" on page 3-7.</p>	NG →	<p>Re-gap or replace the spark plug.</p>
OK ↓		
<p>4. Check the ignition spark gap. Refer to "CHECKING THE IGNITION SPARK GAP" on page 8-70.</p>	OK →	<p>Ignition system is OK.</p>
NG ↓		
<p>5. Check the spark plug cap. Refer to "CHECKING THE SPARK PLUG CAP" on page 8-69.</p>	NG →	<p>Replace the spark plug cap.</p>
OK ↓		
<p>6. Check the ignition coil. Refer to "CHECKING THE IGNITION COIL" on page 8-70.</p>	NG →	<p>Replace the ignition coil.</p>
OK ↓		
<p>7. Check the crankshaft position sensor. Refer to "CHECKING THE CRANKSHAFT POSITION SENSOR" on page 8-71.</p>	NG →	<p>Replace the crankshaft position sensor/stator assembly.</p>
OK ↓		
<p>8. Check the main switch. Refer to "CHECKING THE SWITCHES" on page 8-61.</p>	NG →	<p>Replace the main switch.</p>
OK ↓		

---

9. Check the engine stop switch. Refer to "CHECKING THE SWITCHES" on page 8-61.	NG →	The engine stop switch is faulty. Replace the right handlebar switch.
OK ↓		
10. Check the sidestand switch. Refer to "CHECKING THE SWITCHES" on page 8-61.	NG →	Replace the sidestand switch.
OK ↓		
11. Check the lean angle sensor. Refer to "CHECKING THE SWITCHES" on page 8-61.	NG →	Replace the lean angle sensor.
OK ↓		
12. Check the entire ignition system wiring. Refer to "CIRCUIT DIAGRAM" on page 8-1.	NG →	Properly connect or repair the ignition system wiring.
OK ↓		
Replace the ECU.		

EAS27160  
ELECTRIC STARTING SYSTEM

EAS27170  
CIRCUIT DIAGRAM

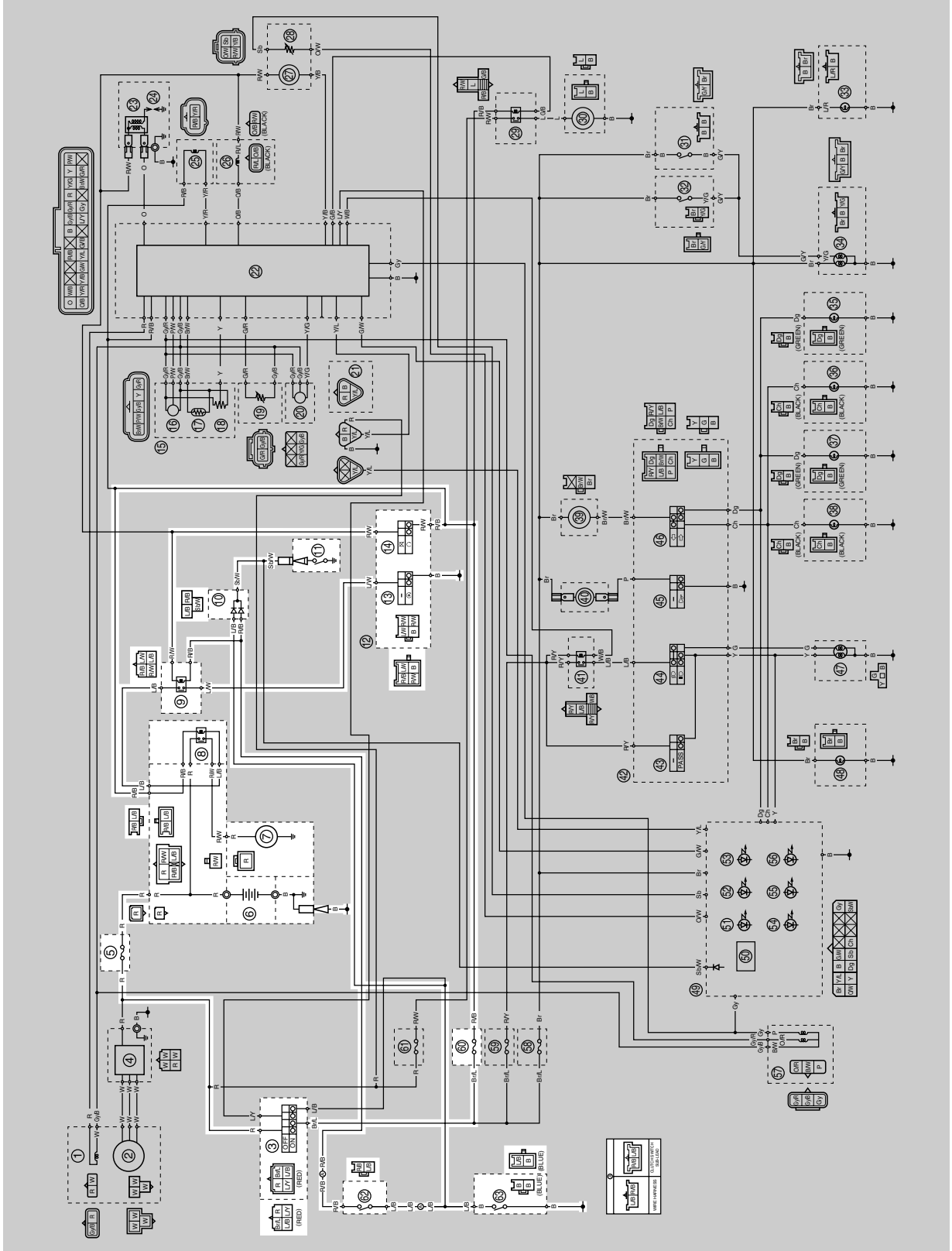



- 3. Main switch
- 5. Main fuse
- 6. Battery
- 7. Starter motor
- 8. Starter relay
- 9. Starting circuit cut-off relay
- 10. Diode
- 11. Neutral switch
- 13. Start switch
- 14. Engine stop switch
- 60. Ignition fuse
- 62. Clutch switch
- 63. Sidestand switch

EAS27180

**STARTING CIRCUIT CUT-OFF SYSTEM OPERATION**

If the engine stop switch is set to "○" and the main switch is set to "ON" (both switch circuits are closed), the starter motor can only operate if at least one of the following conditions is met:

- The transmission is in neutral (the neutral switch circuit is closed).
- The clutch lever is pulled to the handlebar (the clutch switch circuit is closed) and the sidestand is up (the sidestand switch circuit is closed).

The starting circuit cut-off relay prevents the starter motor from operating when neither of these conditions has been met. In this instance, the starting circuit cut-off relay is open so current cannot reach the starter motor. When at least one of the above conditions has been met, the starting circuit cut-off relay is closed and the engine can be started by pressing the start switch "⊗".

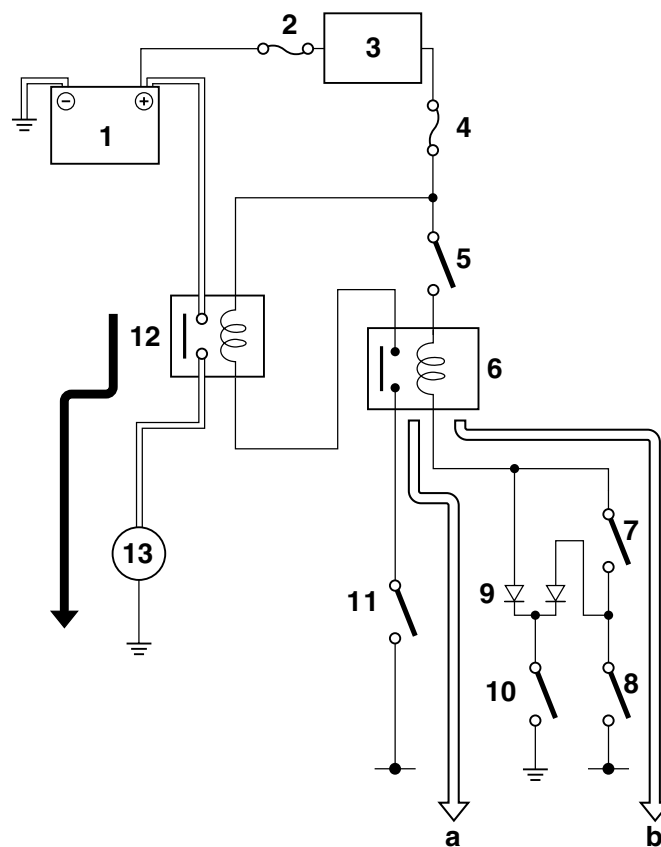

- a. WHEN THE TRANSMISSION IS IN NEUTRAL
- b. WHEN THE CLUTCH LEVER IS PULLED TO THE HANDLEBAR AND THE SIDESTAND IS UP
1. Battery
  2. Main fuse
  3. Main switch
  4. Ignition fuse
  5. Engine stop switch
  6. Starting circuit cut-off relay

7. Clutch switch
8. Sidestand switch
9. Diode
10. Neutral switch
11. Start switch
12. Starter relay
13. Starter motor

EAS27190

**TROUBLESHOOTING**

The starter motor fails to turn.

**TIP**

• Before troubleshooting, remove the following part(s):

1. Battery cover
2. Battery
3. Headlight assembly
4. Fuel tank

<p>1. Check the fuses. (Main and ignition) Refer to "CHECKING THE FUSES" on page 8-65.</p>	<p>NG →</p>	<p>Replace the fuse(s).</p>
<p>OK ↓</p>		
<p>2. Check the battery. Refer to "CHECKING AND CHARGING THE BATTERY" on page 8-65.</p>	<p>NG →</p>	<ul style="list-style-type: none"> <li>• Refill battery fluid.</li> <li>• Clean the battery terminals.</li> <li>• Recharge or replace the battery.</li> </ul>
<p>OK ↓</p>		
<p>3. Check the starter motor operation. Refer to "CHECKING THE STARTER MOTOR OPERATION" on page 8-72.</p>	<p>OK →</p>	<p>Starter motor is OK. Perform the electric starting system troubleshooting, starting with step 5.</p>
<p>NG ↓</p>		
<p>4. Check the starter motor. Refer to "CHECKING THE STARTER MOTOR" on page 5-36.</p>	<p>NG →</p>	<p>Repair or replace the starter motor.</p>
<p>OK ↓</p>		
<p>5. Check the starting circuit cut-off relay. Refer to "CHECKING THE RELAYS" on page 8-67.</p>	<p>NG →</p>	<p>Replace the starting circuit cut-off relay.</p>
<p>OK ↓</p>		
<p>6. Check the diode. Refer to "CHECKING THE DIODE" on page 8-69.</p>	<p>NG →</p>	<p>Replace the diode.</p>
<p>OK ↓</p>		
<p>7. Check the starter relay. Refer to "CHECKING THE RELAYS" on page 8-67.</p>	<p>NG →</p>	<p>Replace the starter relay.</p>
<p>OK ↓</p>		

<p>8. Check the main switch. Refer to "CHECKING THE SWITCHES" on page 8-61.</p>	<p>NG →</p>	<p>Replace the main switch.</p>
<p>OK ↓</p>		
<p>9. Check the engine stop switch. Refer to "CHECKING THE SWITCHES" on page 8-61.</p>	<p>NG →</p>	<p>The engine stop switch is faulty. Replace the right handlebar switch.</p>
<p>OK ↓</p>		
<p>10. Check the neutral switch. Refer to "CHECKING THE SWITCHES" on page 8-61.</p>	<p>NG →</p>	<p>Replace the neutral switch.</p>
<p>OK ↓</p>		
<p>11. Check the sidestand switch. Refer to "CHECKING THE SWITCHES" on page 8-61.</p>	<p>NG →</p>	<p>Replace the sidestand switch.</p>
<p>OK ↓</p>		
<p>12. Check the clutch switch. Refer to "CHECKING THE SWITCHES" on page 8-61.</p>	<p>NG →</p>	<p>Replace the clutch switch.</p>
<p>OK ↓</p>		
<p>13. Check the start switch. Refer to "CHECKING THE SWITCHES" on page 8-61.</p>	<p>NG →</p>	<p>The start switch is faulty. Replace the right handlebar switch.</p>
<p>OK ↓</p>		
<p>14. Check the entire starting system wiring. Refer to "CIRCUIT DIAGRAM" on page 8-5.</p>	<p>NG →</p>	<p>Properly connect or repair the starting system wiring.</p>
<p>OK ↓</p>		
<p>The starting system circuit is OK.</p>		



EAS27200

CHARGING SYSTEM

EAS27210

CIRCUIT DIAGRAM

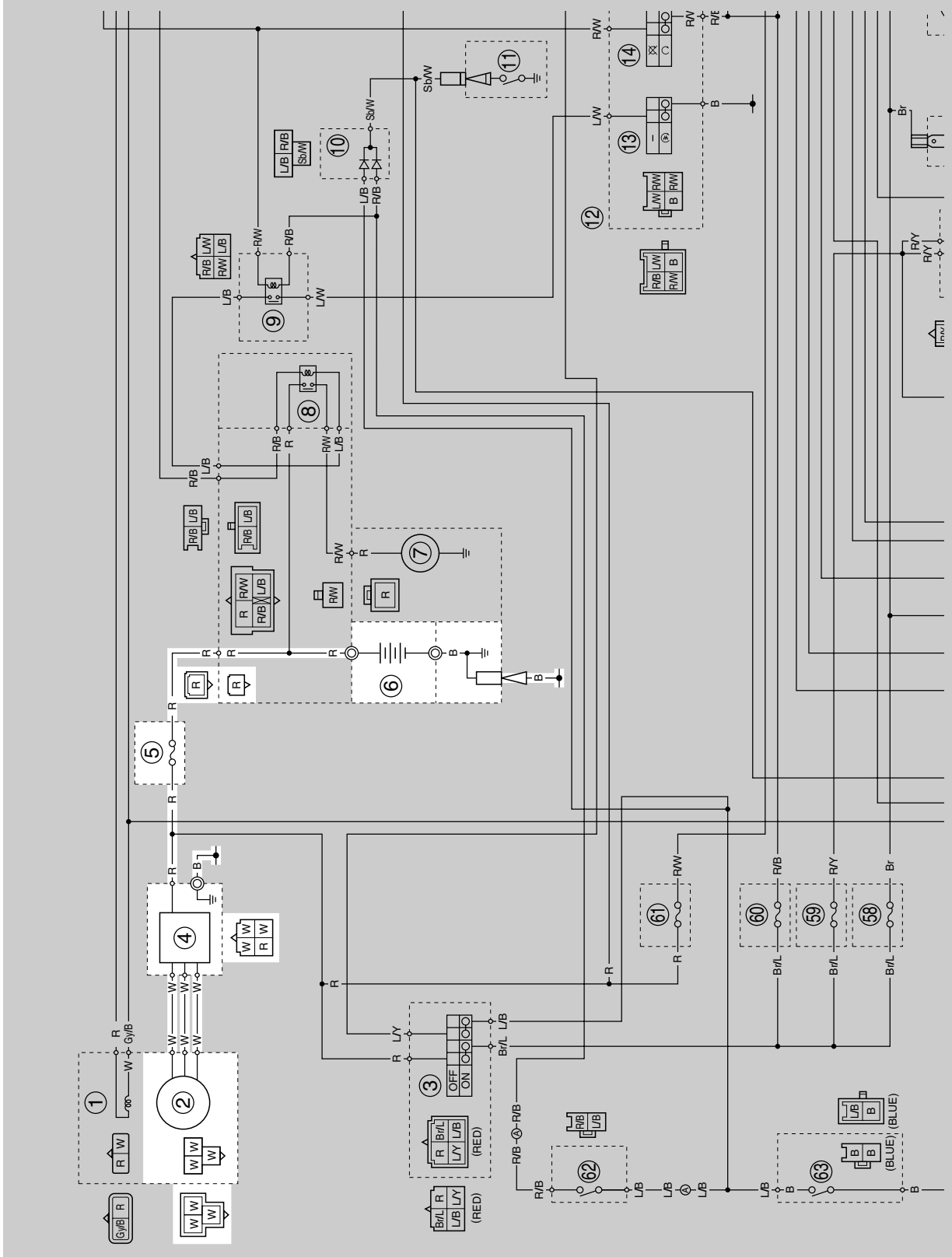

2. AC magneto
4. Rectifier/regulator
5. Main fuse
6. Battery

EAS27230

### TROUBLESHOOTING

The battery is not being charged.

#### TIP

• Before troubleshooting, remove the following part(s):

1. Seat
2. Battery cover

<p>1. Check the fuse. (Main) Refer to "CHECKING THE FUSES" on page 8-65.</p>	NG →	<p>Replace the fuse.</p>
OK ↓		
<p>2. Check the battery. Refer to "CHECKING AND CHARGING THE BATTERY" on page 8-65.</p>	NG →	<ul style="list-style-type: none"> <li>• Refill battery fluid.</li> <li>• Clean the battery terminals.</li> <li>• Recharge or replace the battery.</li> </ul>
OK ↓		
<p>3. Check the stator coil. Refer to "CHECKING THE STATOR COIL" on page 8-72.</p>	NG →	<p>Replace the crankshaft position sensor/stator assembly.</p>
OK ↓		
<p>4. Check the rectifier/regulator. Refer to "CHECKING THE RECTIFIER/REGULATOR" on page 8-72.</p>	NG →	<p>Replace the rectifier/regulator.</p>
OK ↓		
<p>5. Check the entire charging system wiring. Refer to "CIRCUIT DIAGRAM" on page 8-11.</p>	NG →	<p>Properly connect or repair the charging system wiring.</p>
OK ↓		
<p>The charging system circuit is OK.</p>		





EAS27240

LIGHTING SYSTEM

EAS27250

CIRCUIT DIAGRAM

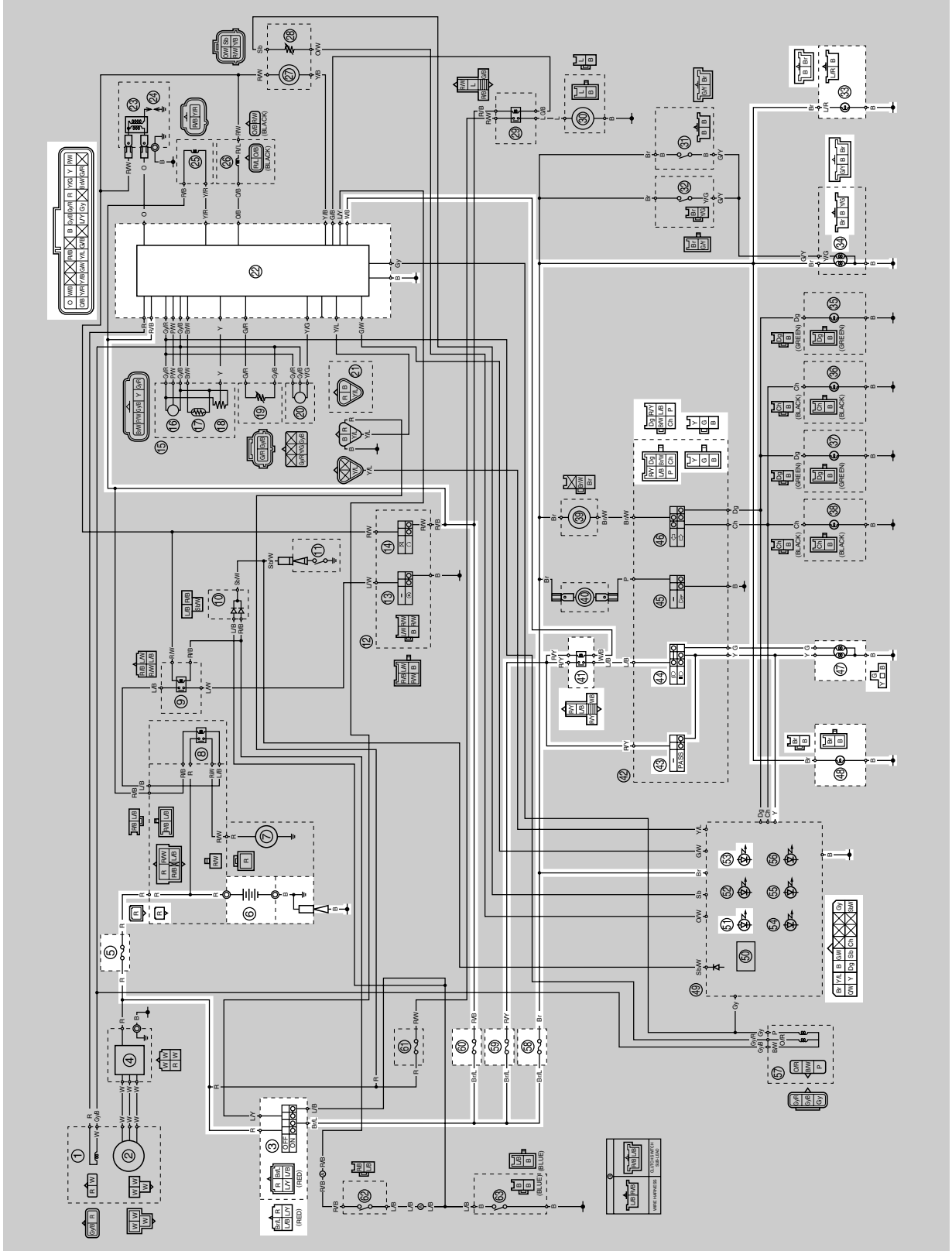

- 3. Main switch
- 5. Main fuse
- 6. Battery
- 22. ECU (engine control unit)
- 33. License plate light
- 34. Tail/brake light
- 41. Headlight relay
- 43. Pass switch
- 44. Dimmer switch
- 47. Headlight
- 48. Auxiliary light
- 51. Meter light
- 53. High beam indicator light
- 58. Signaling system fuse
- 59. Headlight fuse
- 60. Ignition fuse

EAS27260

## TROUBLESHOOTING

Any of the following fail to light: headlight, high beam indicator light, taillight, license plate light, auxiliary light or meter light.

### TIP

• Before troubleshooting, remove the following part(s):

1. Battery cover
2. Fuel tank

<p>1. Check the condition of each bulb and bulb socket. Refer to "CHECKING THE BULBS AND BULB SOCKETS" on page 8-64.</p>	<p>NG →</p>	<p>Replace the bulb(s) and bulb socket(s).</p>
<p>OK ↓</p>		
<p>2. Check the fuses. (Main, ignition, headlight, and signaling system) Refer to "CHECKING THE FUSES" on page 8-65.</p>	<p>NG →</p>	<p>Replace the fuse(s).</p>
<p>OK ↓</p>		
<p>3. Check the battery. Refer to "CHECKING AND CHARGING THE BATTERY" on page 8-65.</p>	<p>NG →</p>	<ul style="list-style-type: none"> <li>• Refill battery fluid.</li> <li>• Clean the battery terminals.</li> <li>• Recharge or replace the battery.</li> </ul>
<p>OK ↓</p>		
<p>4. Check the main switch. Refer to "CHECKING THE SWITCHES" on page 8-61.</p>	<p>NG →</p>	<p>Replace the main switch.</p>
<p>OK ↓</p>		
<p>5. Check the dimmer switch. Refer to "CHECKING THE SWITCHES" on page 8-61.</p>	<p>NG →</p>	<p>The dimmer switch is faulty. Replace the left handlebar switch.</p>
<p>OK ↓</p>		
<p>6. Check the pass switch. Refer to "CHECKING THE SWITCHES" on page 8-61.</p>	<p>NG →</p>	<p>The pass switch is faulty. Replace the left handlebar switch.</p>
<p>OK ↓</p>		
<p>7. Check the headlight relay. Refer to "CHECKING THE RELAYS" on page 8-67.</p>	<p>NG →</p>	<p>Replace the headlight relay.</p>
<p>OK ↓</p>		

8. Check the entire lighting system wiring.  
Refer to "CIRCUIT DIAGRAM" on page 8-15.

OK ↓

Replace the ECU or meter assembly.

NG →

Properly connect or repair the lighting system wiring.

EAS27270  
**SIGNALING SYSTEM**

EAS27280  
**CIRCUIT DIAGRAM**

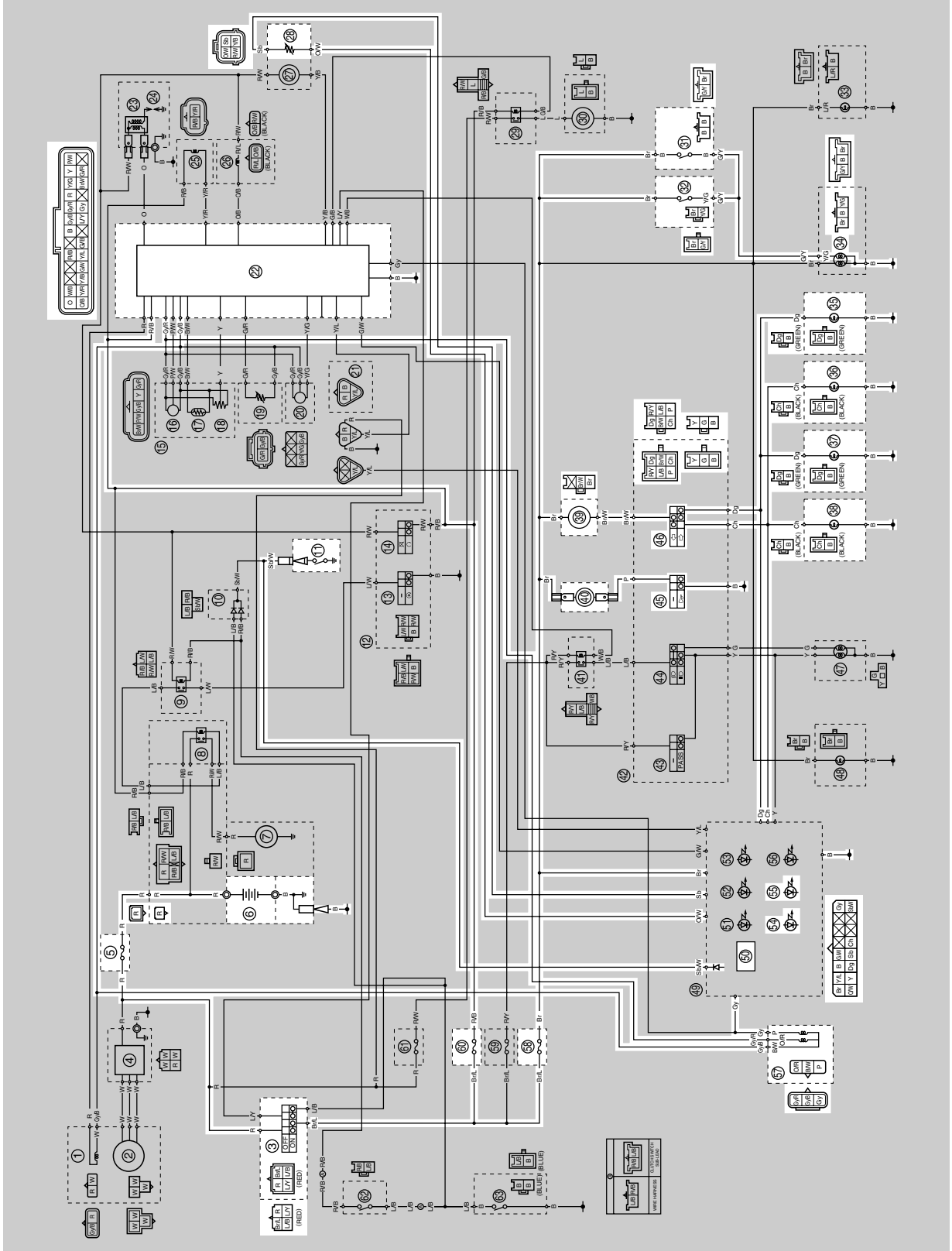

- 3. Main switch
- 5. Main fuse
- 6. Battery
- 11. Neutral switch
- 22. ECU (engine control unit)
- 28. Fuel sender
- 31. Rear brake light switch
- 32. Front brake light switch
- 34. Tail/brake light
- 35. Rear right turn signal light
- 36. Rear left turn signal light
- 37. Front right turn signal light
- 38. Front left turn signal light
- 39. Turn signal relay
- 40. Horn
- 45. Horn switch
- 46. Turn signal switch
- 50. Multi-function meter
- 54. Turn signal indicator light
- 55. Neutral indicator light
- 57. Speed sensor
- 58. Signaling system fuse
- 60. Ignition fuse

EAS27290

## TROUBLESHOOTING

- Any of the following fail to light: turn signal lights, brake light or indicator lights.
- The horn fails to sound.
- The fuel meter fails to operate.
- The speedometer fails to operate.

### TIP

- Before troubleshooting, remove the following part(s):
  1. Battery cover
  2. Rear fender
  3. Headlight assembly
  4. Fuel tank

<p>1. Check the fuses. (Main, ignition, and signaling system) Refer to "CHECKING THE FUSES" on page 8-65.</p>	<p>NG →</p>	<p>Replace the fuse(s).</p>
<p>OK ↓</p>		
<p>2. Check the battery. Refer to "CHECKING AND CHARGING THE BATTERY" on page 8-65.</p>	<p>NG →</p>	<ul style="list-style-type: none"> <li>• Refill battery fluid.</li> <li>• Clean the battery terminals.</li> <li>• Recharge or replace the battery.</li> </ul>
<p>OK ↓</p>		
<p>3. Check the main switch. Refer to "CHECKING THE SWITCHES" on page 8-61.</p>	<p>NG →</p>	<p>Replace the main switch.</p>
<p>OK ↓</p>		
<p>4. Check the entire signaling system wiring. Refer to "CIRCUIT DIAGRAM" on page 8-19.</p>	<p>NG →</p>	<p>Properly connect or repair the signaling system wiring.</p>
<p>OK ↓</p>		
<p>Check the condition of each of the signaling system circuits. Refer to "Checking the signaling system".</p>		

### Checking the signaling system

The horn fails to sound.

<p>1. Check the horn switch. Refer to "CHECKING THE SWITCHES" on page 8-61.</p>	<p>NG →</p>	<p>Replace the left handlebar switch.</p>
<p>OK ↓</p>		



2. Check the horn.  
Refer to "CHECKING THE HORN" on page 8-73.

NG →

Replace the horn.

OK ↓

3. Check the entire signaling system wiring.  
Refer to "CIRCUIT DIAGRAM" on page 8-19.

NG →

Properly connect or repair the signaling system wiring.

OK ↓

This circuit is OK.

### The tail/brake light fails to come on.

1. Check the tail/brake light bulb and socket.  
Refer to "CHECKING THE BULBS AND BULB SOCKETS" on page 8-64.

NG →

Replace the tail/brake light bulb, socket or both.

OK ↓

2. Check the front brake light switch.  
Refer to "CHECKING THE SWITCHES" on page 8-61.

NG →

Replace the front brake light switch.

OK ↓

3. Check the rear brake light switch.  
Refer to "CHECKING THE SWITCHES" on page 8-61.

NG →

Replace the rear brake light switch.

OK ↓

4. Check the entire signaling system wiring.  
Refer to "CIRCUIT DIAGRAM" on page 8-19.

NG →

Properly connect or repair the signaling system wiring.

OK ↓

This circuit is OK.

### The turn signal light, turn signal indicator light or both fail to blink.

1. Check the turn signal light bulb and socket.  
Refer to "CHECKING THE BULBS AND BULB SOCKETS" on page 8-64.

NG →

Replace the turn signal light bulb, socket or both.

OK ↓

<p>2. Check the turn signal switch. Refer to "CHECKING THE SWITCHES" on page 8-61.</p>	<p>NG →</p>	<p>The turn signal switch is faulty. Replace the left handlebar switch.</p>
<p>OK ↓</p>		
<p>3. Check the turn signal relay. Refer to "CHECKING THE RELAYS" on page 8-67.</p>	<p>NG →</p>	<p>Replace the turn signal relay.</p>
<p>OK ↓</p>		
<p>4. Check the entire signaling system wiring. Refer to "CIRCUIT DIAGRAM" on page 8-19.</p>	<p>NG →</p>	<p>Properly connect or repair the signaling system wiring.</p>
<p>OK ↓</p>		
<p>Replace the meter assembly.</p>		
<p><u>The neutral indicator light fails to come on.</u></p>		
<p>1. Check the neutral switch. Refer to "CHECKING THE SWITCHES" on page 8-61.</p>	<p>NG →</p>	<p>Replace the neutral switch.</p>
<p>OK ↓</p>		
<p>2. Check the entire signaling system wiring. Refer to "CIRCUIT DIAGRAM" on page 8-19.</p>	<p>NG →</p>	<p>Properly connect or repair the signaling system wiring.</p>
<p>OK ↓</p>		
<p>Replace the meter assembly.</p>		
<p><u>The fuel meter fails to come on.</u></p>		
<p>1. Check the fuel sender. Refer to "CHECKING THE FUEL SENDER" on page 8-73.</p>	<p>NG →</p>	<p>Replace the fuel pump.</p>
<p>OK ↓</p>		
<p>2. Check the entire signaling system wiring. Refer to "CIRCUIT DIAGRAM" on page 8-19.</p>	<p>NG →</p>	<p>Properly connect or repair the signaling system wiring.</p>
<p>OK ↓</p>		
<p>Replace the meter assembly.</p>		

The speedometer fails to operate.

1. Check the speed sensor.  
Refer to "CHECKING THE SPEED SENSOR" on page 8-74.

NG →

Replace the speed sensor.

OK ↓

2. Check the entire signaling system wiring.  
Refer to "CIRCUIT DIAGRAM" on page 8-19.

NG →

Properly connect or repair the signaling system wiring.

OK ↓

Replace the ECU or meter assembly.

EAS27300

COOLING SYSTEM

EAS27310

CIRCUIT DIAGRAM

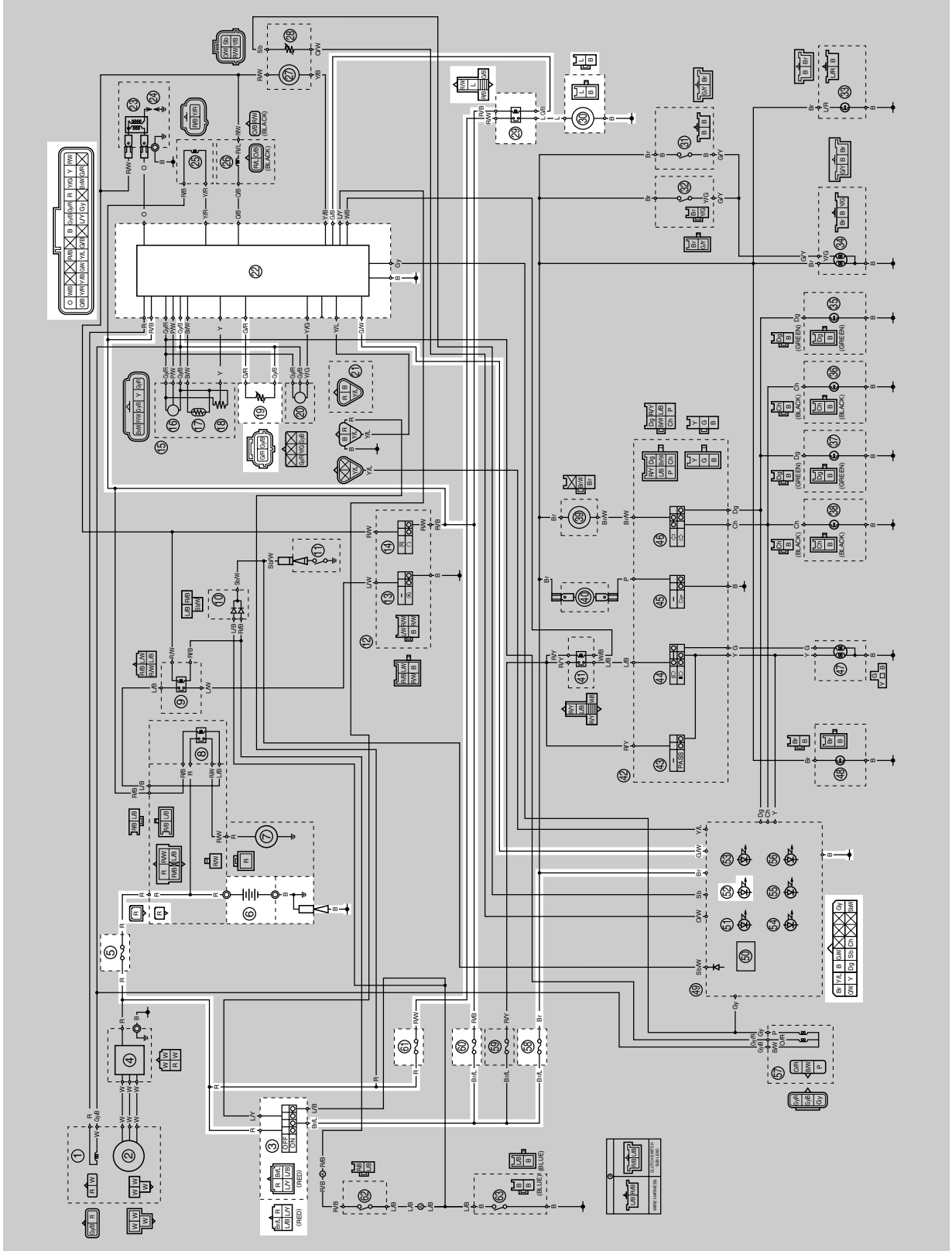

- 3. Main switch
- 5. Main fuse
- 6. Battery
- 19. Coolant temperature sensor
- 22. ECU (engine control unit)
- 29. Radiator fan motor relay
- 30. Radiator fan motor
- 52. Coolant temperature warning light
- 58. Signaling system fuse
- 60. Ignition fuse
- 61. Radiator fan motor fuse

EAS27320

## TROUBLESHOOTING

- The radiator fan motor fails to turn.
- The coolant temperature warning light fails to come on.

### TIP

- Before troubleshooting, remove the following part(s):
  1. Battery cover
  2. Fuel tank

<p>1. Check the fuses. (Main, ignition, signaling system, and radiator fan motor) Refer to "CHECKING THE FUSES" on page 8-65.</p>	<p>NG →</p>	<p>Replace the fuse(s).</p>
<p>OK ↓</p>		
<p>2. Check the battery. Refer to "CHECKING AND CHARGING THE BATTERY" on page 8-65.</p>	<p>NG →</p>	<ul style="list-style-type: none"> <li>• Refill battery fluid.</li> <li>• Clean the battery terminals.</li> <li>• Recharge or replace the battery.</li> </ul>
<p>OK ↓</p>		
<p>3. Check the main switch. Refer to "CHECKING THE SWITCHES" on page 8-61.</p>	<p>NG →</p>	<p>Replace the main switch.</p>
<p>OK ↓</p>		
<p>4. Check the radiator fan motor. Refer to "CHECKING THE RADIATOR FAN MOTOR" on page 8-74.</p>	<p>NG →</p>	<p>Replace the radiator fan motor.</p>
<p>OK ↓</p>		
<p>5. Check the radiator fan motor relay. Refer to "CHECKING THE RELAYS" on page 8-67.</p>	<p>NG →</p>	<p>Replace the radiator fan motor relay.</p>
<p>OK ↓</p>		
<p>6. Check the coolant temperature sensor. Refer to "CHECKING THE COOLANT TEMPERATURE SENSOR" on page 8-75.</p>	<p>NG →</p>	<p>Replace the coolant temperature sensor.</p>
<p>OK ↓</p>		
<p>7. Check the entire cooling system wiring. Refer to "CIRCUIT DIAGRAM" on page 8-25.</p>	<p>NG →</p>	<p>Properly connect or repair the cooling system wiring.</p>
<p>OK ↓</p>		
<p>Replace the ECU or meter assembly.</p>		



EAS27330

FUEL INJECTION SYSTEM

EAS27340

CIRCUIT DIAGRAM

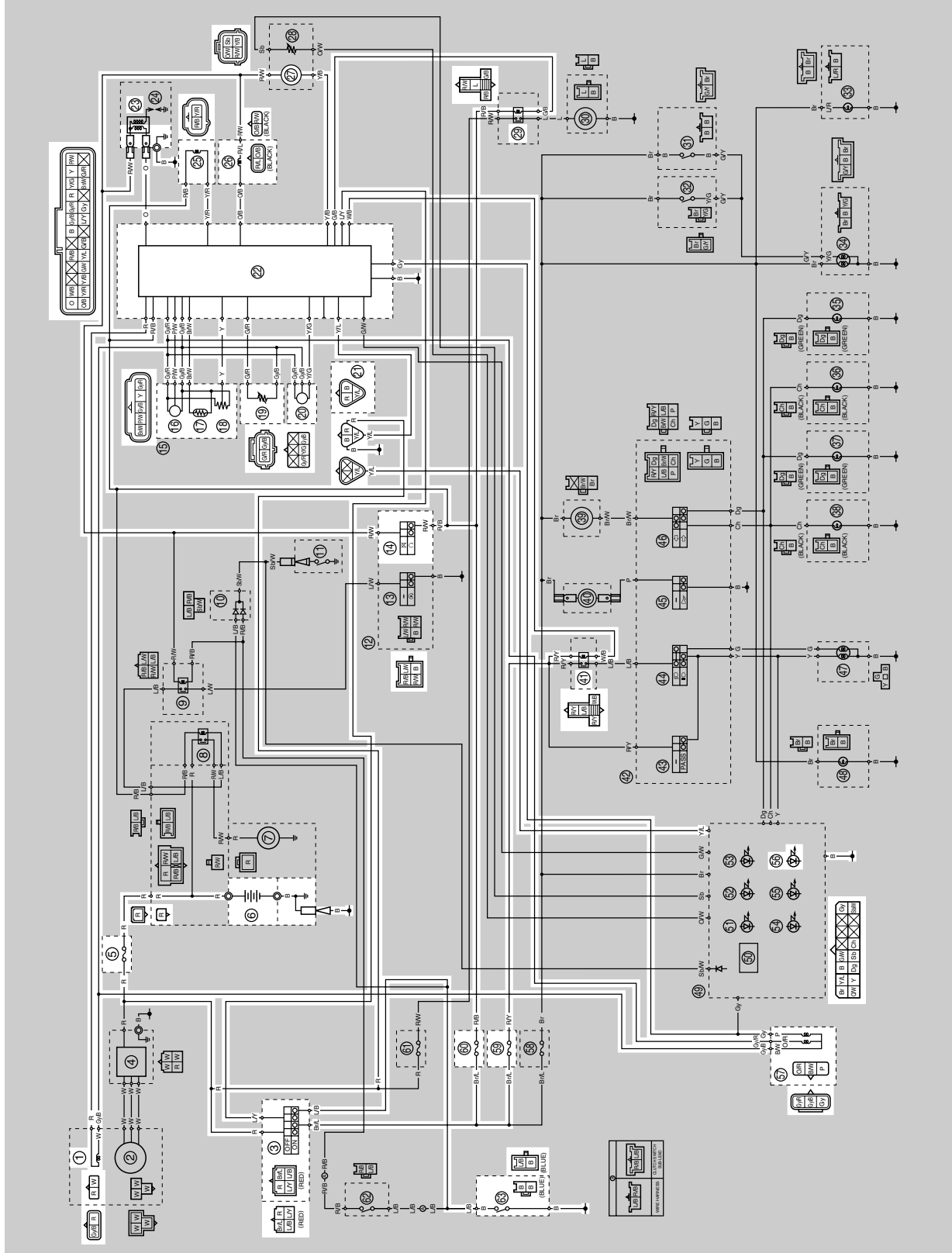



1. Crankshaft position sensor
3. Main switch
5. Main fuse
6. Battery
14. Engine stop switch
16. Intake air pressure sensor
17. Intake air temperature sensor
18. Throttle position sensor
19. Coolant temperature sensor
20. Lean angle sensor
21. Self-diagnosis signal coupler
22. ECU (engine control unit)
23. Ignition coil
25. FID (fast idle solenoid)
26. Fuel injector
27. Fuel pump
29. Radiator fan motor relay
41. Headlight relay
56. Engine trouble warning light
57. Speed sensor
59. Headlight fuse
60. Ignition fuse
63. Sidestand switch

EAS27350

## ECU SELF-DIAGNOSTIC FUNCTION

The ECU is equipped with a self-diagnostic function in order to ensure that the fuel injection system is operating normally. If this function detects a malfunction in the system, it immediately operates the engine under substitute characteristics and illuminates the engine trouble warning light to alert the rider that a malfunction has occurred in the system. Once a malfunction has been detected, a fault code is stored in the memory of the ECU.

- To inform the rider that the fuel injection system is not functioning, the engine trouble warning light flashes when the start switch is being pushed to start the engine.
- If a malfunction is detected in the system by the self-diagnostic function, the ECU provides an appropriate substitute characteristic operation, and alerts the rider of the detected malfunction by illuminating the engine trouble warning light.
- After the engine has been stopped, the lowest fault code number is indicated by the engine trouble warning light (or displayed on the FI diagnostic tool). It remains stored in the memory of the ECU until it is deleted.

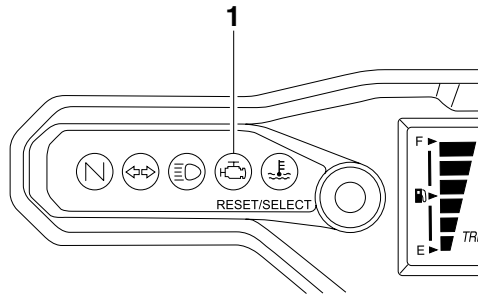

1. Engine trouble warning light

### Engine trouble warning light fault code indication

Digit of 10: Cycles of 1 sec. on and 1.5 sec. off.

Digit of 1: Cycles of 0.5 sec. on and 0.5 sec. off.

**Example: 42**

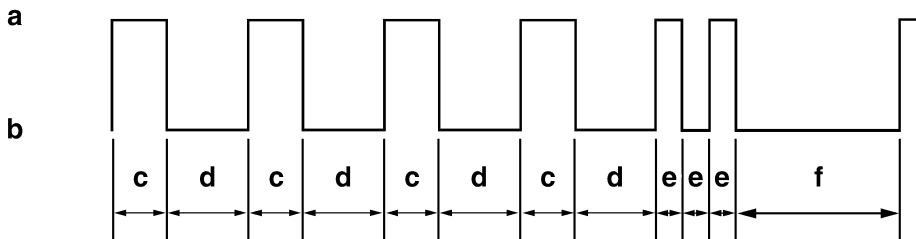

- a. Light on
- b. Light off
- c. 1
- d. 1.5
- e. 0.5
- f. 3

**Engine trouble warning light indication and fuel injection system operation**

Warning light indication	ECU operation	Fuel injection operation	Vehicle operation
Flashing*	Warning provided when unable to start engine	Operation stopped	Cannot be operated
Remains on	Malfunction detected	Operated with substitute characteristics in accordance with the description of the malfunction	Can or cannot be operated depending on the fault code

\* The warning light flashes when any one of the conditions listed below is present and the start switch is pushed:

- |   |   |
|---|---|
| 19: Blue/yellow ECU lead (broken or disconnected) | 39: Fuel injector (open or short circuit)         |
| 30: Lean angle sensor (latch up detected)         | 41: Lean angle sensor (open or short circuit)     |
| 33: Faulty ignition                               | 50: ECU internal malfunction (memory check error) |

**Checking the engine trouble warning light**

The engine trouble warning light comes on for 3 seconds after the main switch has been set to "ON". If the warning light does not come on under these conditions, the warning light (LED) may be defective.



- |                                     |  |
|-------------------------------------|--|
| a. Main switch "OFF"                | d. Engine trouble warning light on for 3 seconds |
| b. Main switch "ON"                 |  |
| c. Engine trouble warning light off |  |

EAS22B1023

**SELF-DIAGNOSTIC FUNCTION TABLE**

If the ECU detects an abnormal signal from a sensor while the vehicle is being driven, the ECU illuminates the engine trouble warning light and provides the engine with alternate operating instructions that are appropriate for the type of malfunction.

When an abnormal signal is received from a sensor, the ECU processes the specified values that are programmed for each sensor in order to provide the engine with alternate operating instructions that enable the engine to continue to operate or stop operating, depending on the conditions.

Self-Diagnostic Function table

Fault code No.	Item	Symptom	Able / unable to start	Able / unable to drive
12	Crankshaft position sensor	No normal signals are received from the crankshaft position sensor.	Unable	Unable
13	Intake air pressure sensor (open or short circuit)	Intake air pressure sensor: open or short circuit detected.	Able	Able
14	Intake air pressure sensor (system)	Throttle body malfunction (clogged intake air pressure sensor hole or improperly installed throttle body sensor assembly). Intake air system malfunction (correct pressure is not supplied to throttle body sensor assembly).	Able	Able
15	Throttle position sensor (open or short circuit)	Throttle position sensor: open or short circuit detected.	Able	Able
16	Throttle position sensor (stuck)	Stuck throttle position sensor detected.	Able	Able
19	Blue/yellow ECU lead (broken or disconnected)	A break or disconnection of the blue/yellow lead of the ECU is detected.	Unable	Unable
21	Coolant temperature sensor (open or short circuit)	Coolant temperature sensor: open or short circuit detected.	Able	Able
22	Intake air temperature sensor (open or short circuit)	Intake air temperature sensor: open or short circuit detected.	Able	Able
30	Lean angle sensor (latch up detected)	Latch up detected. No normal signal is received from the lean angle sensor.	Unable	Unable
33	Ignition coil (open circuit)	Primary lead of the ignition coil: open circuit detected.	Unable	Unable
39	Fuel injector	Fuel injector: open or short circuit detected.	Unable	Unable
41	Lean angle sensor (open or short circuit)	Lean angle sensor: open or short circuit detected.	Unable	Unable
42	Speed sensor	No normal signals are received from the speed sensor.	Able	Able
44	EEPROM	Error is detected while reading from or writing on EEPROM.	Able	Able
46	Vehicle system power supply (Monitoring voltage)	Power supply to the fuel injection system is not normal.	Able	Able

Fault code No.	Item	Symptom	Able / unable to start	Able / unable to drive
50	ECU internal malfunction (memory check error)	Faulty ECU memory. (When this malfunction is detected in the ECU, the fault code number might not appear on the FI diagnostic tool.)	Unable	Unable
—	Start unable warning	Engine trouble warning light flashes when the start switch is pushed.	Unable	Unable

EAS27400

**TROUBLESHOOTING METHOD**

**The engine operation is not normal and the engine trouble warning light comes on.**

1. Check:

- Fault code number



- Check the fault code number displayed on the FI diagnostic tool.
- Identify the system with the fault code. Refer to “Self-Diagnostic Function table”.
- Identify the probable cause of the malfunction. Refer to “Diagnostic code table”.



2. Check and repair the probable cause of the malfunction.

Fault code No.	No fault code No.
Check and repair. Refer to “TROUBLESHOOTING DETAILS” on page 8-42. Monitor the operation of the sensors and actuators in the diagnostic mode. Refer to “Sensor operation table” and “Actuator operation table”.	Check and repair. Refer to “Self-Diagnostic Function table”.

- Perform fuel injection system reinstatement action.  
Refer to “Reinstatement method” of table in “TROUBLESHOOTING DETAILS” on page 8-42.
- Set the main switch to “OFF”, then to “ON” again, and then check that no fault code number is displayed.

**TIP**

If another fault code is displayed, repeat steps (1) to (4) until no fault code number is displayed.

- Erase the malfunction history in the diagnostic mode. Refer to “Sensor operation table (Diagnostic code No. D62)”.

**TIP**

Setting the main switch to “OFF” will not erase the malfunction history.

**The engine operation is not normal but the engine trouble warning light does not come on.**

- Check the operation of the following sensors and actuators in the Diagnostic mode. Refer to “Sensor operation table” and “Actuator operation table”.

30: Ignition coil 36: Fuel injector
--

If a malfunction is detected in the sensors or actuators, repair or replace all faulty parts. If no malfunction is detected in the sensors and actuators, check and repair the inner parts of the engine.

EAS27431

**DIAGNOSTIC MODE**

It is possible to monitor the sensor output data or check the activation of actuators with the FI diagnostic tool connected to the vehicle and set to the normal mode or the diagnostic monitoring mode.



**FI diagnostic tool**  
90890-03182

### Setting the normal mode

#### TIP

The engine speed, coolant temperature, and fault codes, if detected, can be displayed on the LCD of the FI diagnostic tool when the tool is connected to the vehicle and is set to the normal mode.

1. Set the main switch to "OFF" and the engine stop switch to "○".
2. Disconnect the self-diagnosis signal coupler "1", and then connect the FI diagnostic tool "2" as shown.

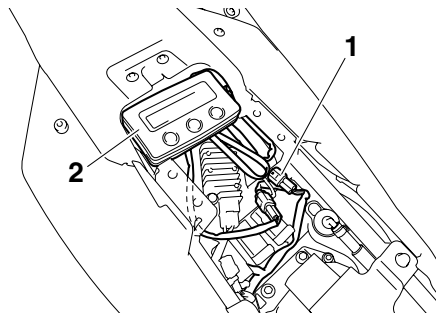

3. Set the main switch to "ON" and start the engine.

#### TIP

- The coolant temperature and engine speed appear on the LCD of the FI diagnostic tool.
- The "POWER" LED (green) comes on.
- If a malfunction is detected in the system, the "WARNING" LED (orange) comes on.

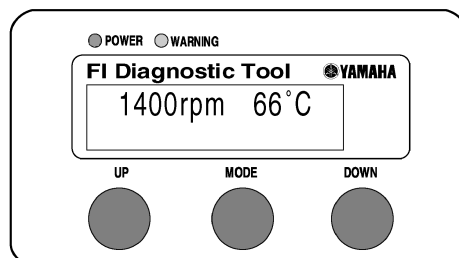

4. Turn the engine off.

#### TIP

If a malfunction is detected in the system, the fault code appears on the LCD of the FI diagnostic tool. In addition, the "WARNING" LED (orange) comes on.

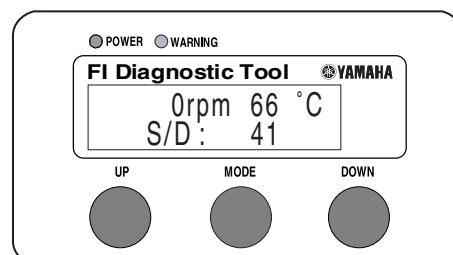

5. Set the main switch to "OFF" to cancel the normal mode.
6. Disconnect the FI diagnostic tool and connect the self-diagnosis signal coupler.

### Setting the diagnostic mode

1. Set the main switch to "OFF" and the engine stop switch to "○".
2. Disconnect the self-diagnosis signal coupler "1", and then connect the FI diagnostic tool "2" as shown.

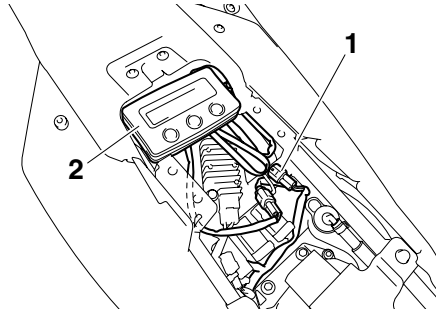

3. Disconnect the fuel pump coupler.
4. While pressing the "MODE" button, set the main switch to "ON".

#### TIP

- "DIAG" appears on the LCD of the FI diagnostic tool.
- The "POWER" LED (green) comes on.

5. Press the "UP" button to select the CO adjustment mode "CO" or the diagnostic mode "DIAG".
6. After selecting "DIAG", press the "MODE" button.
7. Select the diagnostic code number corresponding to the fault code number by pressing the "UP" and "DOWN" buttons.

#### TIP

- The diagnostic code number appears on the LCD (D01-D70).
- To decrease the selected diagnostic code number, press the "DOWN" button. Press the "DOWN" button for 1 second or longer to automatically decrease the diagnostic code numbers.
- To increase the selected diagnostic code number, press the "UP" button. Press the "UP" button for 1 second or longer to automatically increase the diagnostic code numbers.

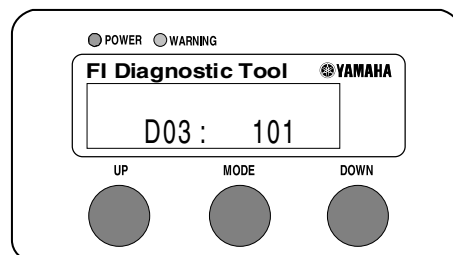

8. Verify the operation of the sensor or actuator.
  - Sensor operation  
The data representing the operating conditions of the sensor appear on the LCD.
  - Actuator operation  
Press the "MODE" button.
9. Set the main switch to "OFF" to cancel the diagnostic mode.
10. Disconnect the FI diagnostic tool and connect the self-diagnosis signal coupler.

Diagnostic code table

Fault code No.	Symptom	Probable cause of malfunction	Diagnostic code No.
12	No normal signals are received from the crankshaft position sensor.	<ul style="list-style-type: none"> <li>• Malfunction in wire harness ECU coupler.</li> <li>• Malfunction in crankshaft position sensor coupler.</li> <li>• Open or short circuit in wire harness.</li> <li>• Defective crankshaft position sensor.</li> <li>• Malfunction in generator rotor.</li> <li>• Malfunction in ECU.</li> <li>• Improperly installed crankshaft position sensor.</li> </ul>	—
13	Intake air pressure sensor: open or short circuit detected.	<ul style="list-style-type: none"> <li>• Malfunction in wire harness ECU coupler.</li> <li>• Malfunction in throttle body sensor assembly coupler.</li> <li>• Open or short circuit in wire harness.</li> <li>• Defective throttle body sensor assembly (intake air pressure sensor).</li> <li>• Malfunction in ECU.</li> </ul>	D03
14	Throttle body malfunction (clogged intake air pressure sensor hole or improperly installed throttle body sensor assembly). Intake air system malfunction (correct pressure is not supplied to throttle body sensor assembly).	<ul style="list-style-type: none"> <li>• Intake air pressure sensor hole is clogged.</li> <li>• Malfunction in ECU.</li> <li>• Improperly installed throttle body sensor assembly.</li> </ul>	D03
15	Throttle position sensor: open or short circuit detected.	<ul style="list-style-type: none"> <li>• Malfunction in wire harness ECU coupler.</li> <li>• Malfunction in throttle body sensor assembly coupler.</li> <li>• Open or short circuit in wire harness.</li> <li>• Defective throttle body sensor assembly (throttle position sensor).</li> <li>• Malfunction in ECU.</li> <li>• Improperly installed throttle body sensor assembly.</li> </ul>	D01
16	Stuck throttle position sensor detected.	<ul style="list-style-type: none"> <li>• Defective throttle body sensor assembly (throttle position sensor).</li> <li>• Stuck throttle position sensor.</li> <li>• Malfunction in ECU.</li> <li>• Improperly installed throttle body sensor assembly.</li> </ul>	D01
19	A break or disconnection of the blue/yellow lead of the ECU is detected.	<ul style="list-style-type: none"> <li>• Malfunction in wire harness ECU coupler.</li> <li>• Open or short circuit in wire harness.</li> <li>• Defective sidestand switch.</li> <li>• Malfunction in ECU.</li> </ul>	D20



Fault code No.	Symptom	Probable cause of malfunction	Diagnostic code No.
21	Coolant temperature sensor: open or short circuit detected.	<ul style="list-style-type: none"> <li>• Malfunction in wire harness ECU coupler.</li> <li>• Malfunction in coolant temperature sensor coupler.</li> <li>• Open or short circuit in wire harness.</li> <li>• Defective coolant temperature sensor.</li> <li>• Malfunction in ECU.</li> <li>• Improperly installed coolant temperature sensor.</li> </ul>	D06
22	Intake air temperature sensor: open or short circuit detected.	<ul style="list-style-type: none"> <li>• Malfunction in wire harness ECU coupler.</li> <li>• Malfunction in throttle body sensor assembly coupler.</li> <li>• Open or short circuit in wire harness.</li> <li>• Defective throttle body sensor assembly (intake air temperature sensor).</li> <li>• Malfunction in ECU.</li> <li>• Improperly installed throttle body sensor assembly.</li> </ul>	D05
30	Latch up detected. No normal signal is received from the lean angle sensor.	<ul style="list-style-type: none"> <li>• The vehicle has overturned.</li> <li>• Defective lean angle sensor.</li> <li>• Malfunction in ECU.</li> <li>• Improperly installed lean angle sensor.</li> </ul>	D08
33	Primary lead of the ignition coil: open circuit detected.	<ul style="list-style-type: none"> <li>• Malfunction in wire harness ECU coupler.</li> <li>• Malfunction in ignition coil connectors.</li> <li>• Open circuit in wire harness.</li> <li>• Malfunction in ignition coil.</li> <li>• Malfunction in ECU.</li> <li>• Malfunction in a component of ignition system.</li> <li>• Improperly installed ignition coil.</li> </ul>	D30
39	Fuel injector: open or short circuit detected.	<ul style="list-style-type: none"> <li>• Malfunction in wire harness ECU coupler.</li> <li>• Malfunction in fuel injector coupler.</li> <li>• Open or short circuit in wire harness.</li> <li>• Defective fuel injector.</li> <li>• Malfunction in ECU.</li> <li>• Improperly installed fuel injector.</li> </ul>	D36
41	Lean angle sensor: open or short circuit detected.	<ul style="list-style-type: none"> <li>• Malfunction in wire harness ECU coupler.</li> <li>• Malfunction in lean angle sensor coupler.</li> <li>• Open or short circuit in wire harness.</li> <li>• Defective lean angle sensor.</li> <li>• Malfunction in ECU.</li> </ul>	D08
42	No normal signals are received from the speed sensor.	<ul style="list-style-type: none"> <li>• Malfunction in wire harness ECU coupler.</li> <li>• Malfunction in speed sensor coupler.</li> <li>• Open or short circuit in wire harness.</li> <li>• Defective speed sensor.</li> <li>• Malfunction in vehicle speed sensor detected.</li> <li>• Malfunction in ECU.</li> </ul>	D07
44	Error is detected while reading or writing on EEPROM.	<ul style="list-style-type: none"> <li>• Malfunction in ECU. (The CO adjustment value is not properly written on or read from the internal memory.)</li> </ul>	D60

Fault code No.	Symptom	Probable cause of malfunction	Diagnostic code No.
46	Power supply to the fuel injection system is not normal.	<ul style="list-style-type: none"> <li>Malfunction in the charging system. Refer to "CHARGING SYSTEM" on page 8-11.</li> </ul>	—
50	Faulty ECU memory. (When this malfunction is detected in the ECU, the fault code number might not appear on the FI diagnostic tool.)	<ul style="list-style-type: none"> <li>Malfunction in ECU. (The program and data are not properly written on or read from the internal memory.)</li> </ul>	—

**Sensor operation table**

Diagnostic code No.	Item	FI diagnostic tool display	Checking method
D01	Throttle angle <ul style="list-style-type: none"> <li>Fully closed position</li> <li>Fully open position</li> </ul>	14–20 97–107	Check for changes in displayed values while opening and closing the throttle.
D03	Intake air pressure	Displays the intake air pressure.	Set the engine stop switch to "○", and then operate the throttle while pushing the start switch "⊗". (If the display value changes, the performance is OK.)
D05	Intake air temperature	Displays the intake air temperature.	Compare the actually measured intake air temperature with the FI diagnostic tool display value.
D06	Coolant temperature	Displays the coolant temperature.	Compare the actually measured coolant temperature with the FI diagnostic tool display value.
D07	Vehicle speed pulse	0–999	Check that the number increases when the front wheel is rotated. The number is cumulative and does not reset each time the wheel is stopped.
D08	Lean angle sensor <ul style="list-style-type: none"> <li>Upright</li> <li>Overturned</li> </ul>	0.4–1.4 3.7–4.4	Remove the lean angle sensor and incline it more than 65 degrees.
D09	Fuel system voltage (battery voltage)	0–18.7 Approximately 12.0	Compare with the actually measured battery voltage. (If the battery voltage is low, recharge the battery.)

Diagnostic code No.	Item	FI diagnostic tool display	Checking method
D20	Sidestand switch • Stand retracted • Stand extended	on off	Extend and retract the side-stand (with the transmission in gear).
D60	EEPROM fault code display • No history • History exists	00 01: CO adjustment value is detected.	—
D61	Malfunction history code display • No history • History exists	00 Fault codes 12–50 • (If more than one code number is detected, the display alternates every two seconds to show all the detected code numbers. When all code numbers are shown, the display repeats the same process.)	—
D62	Malfunction history code erasure • No history • History exists	00 Up to 16 fault codes	— To erase the history, press the “MODE” button of the FI diagnostic tool.
D70	Control number	00–254	—

**Actuator operation table**

Diagnostic code No.	Item	Actuation	Checking method
D30	Ignition coil	When the “MODE” button is pressed, the ignition coil is actuated five times at one-second intervals, and the “WARNING” LED on the FI diagnostic tool comes on each time the coil is actuated.	Check the spark five times. • Connect an ignition checker.

Diagnostic code No.	Item	Actuation	Checking method
D36	Fuel injector	When the "MODE" button is pressed, the fuel injector is actuated five times at one-second intervals, and the "WARNING" LED on the FI diagnostic tool comes on each time the injector is actuated.	Check the operating sound of the injector five times.
D51	Radiator fan motor relay	When the "MODE" button is pressed, the radiator motor relay is actuated five times at five-second intervals (2 seconds on, 3 seconds off), and the "WARNING" LED on the FI diagnostic tool comes on each time the relay is actuated.	Check the operating sound of the radiator fan motor relay five times.
D52	Headlight relay	When the "MODE" button is pressed, the headlight relay is actuated five times at five-second intervals (2 seconds on, 3 seconds off), and the "WARNING" LED on the FI diagnostic tool, the high beam indicator light, and the headlight come on each time the relay is actuated.	Check the operating sound of the headlight relay five times.
D54	FID (fast idle solenoid)	When the "MODE" button is pressed, the FID (fast idle solenoid) is actuated five times at one-second intervals, and the "WARNING" LED on the FI diagnostic tool comes on each time the FID is actuated.	Check the operating sound of the FID five times.

**Communication error with the FI diagnostic tool**

LCD Display	Symptom	Probable cause of malfunction
Waiting for connection....	No signals are received from the ECU.	<ul style="list-style-type: none"> <li>• Connecting lead is not connected properly.</li> <li>• The main switch is set to "OFF".</li> <li>• Malfunction in wire harness ECU coupler.</li> <li>• Malfunction in the FI diagnostic tool coupler.</li> <li>• Open or short circuit in wire harness.</li> <li>• Malfunction in the FI diagnostic tool.</li> <li>• Malfunction in the ECU.</li> </ul>

LCD Display	Symptom	Probable cause of malfunction
ERROR_4	Commands from the FI diagnostic tool are not accepted by the ECU.	<ul style="list-style-type: none"> <li>• Set the main switch to “OFF” once, and then set the FI diagnostic tool to the CO adjustment mode or the diagnostic mode.</li> <li>• Vehicle battery is insufficiently charged.</li> <li>• Malfunction in wire harness ECU coupler.</li> <li>• Malfunction in FI diagnostic tool coupler.</li> <li>• Open or short circuit in wire harness.</li> <li>• Malfunction in the FI diagnostic tool.</li> <li>• Malfunction in the ECU.</li> </ul>

EAS27471

## TROUBLESHOOTING DETAILS

This section describes the measures per fault code number displayed on the FI diagnostic tool. Check and service the items or components that are the probable cause of the malfunction following the order given.

After the check and service of the malfunctioning part have been completed, reset the FI diagnostic tool display according to the reinstatement method.

Fault code No.:

Fault code number displayed on the FI diagnostic tool when the engine failed to work normally. Refer to “Diagnostic code table”.

Diagnostic code No.:

Diagnostic code number to be used when the diagnostic mode is operated. Refer to “Sensor operation table” and “Actuator operation table”.

Fault code No.	12	Symptom	No normal signals are received from the crankshaft position sensor.	
Diagnostic code No.	—	—		
Order	Item/components and probable cause	Check or maintenance job	Reinstatement method	
1	Installed condition of crankshaft position sensor.	Check for looseness or pinching.	Crank the engine.	
2	Connections <ul style="list-style-type: none"> <li>• Crankshaft position sensor coupler</li> <li>• Wire harness ECU coupler</li> </ul>	<ul style="list-style-type: none"> <li>• Check the coupler for any pins that may have pulled out.</li> <li>• Check the locking condition of the coupler.</li> <li>• If there is a malfunction, repair it and connect the coupler securely.</li> </ul>		
3	Open or short circuit in wire harness.	<ul style="list-style-type: none"> <li>• Repair or replace if there is an open or short circuit.</li> <li>• Between the crankshaft position sensor coupler and ECU coupler. (red–red) (gray/black–gray/black)</li> </ul>		
4	Defective crankshaft position sensor.	<ul style="list-style-type: none"> <li>• Replace if defective. Refer to “CHECKING THE CRANKSHAFT POSITION SENSOR” on page 8-71.</li> </ul>		

<b>Fault code No.</b>	<b>13</b>	<b>Symptom</b>	<b>Intake air pressure sensor: open or short circuit detected.</b>	
<b>Diagnostic code No.</b>	<b>D03</b>	<b>Intake air pressure sensor</b>		
<b>Order</b>	<b>Item/components and probable cause</b>	<b>Check or maintenance job</b>	<b>Reinstatement method</b>	
1	Connections <ul style="list-style-type: none"> <li>• Throttle body sensor assembly coupler</li> <li>• Wire harness ECU coupler</li> </ul>	<ul style="list-style-type: none"> <li>• Check the coupler for any pins that may have pulled out.</li> <li>• Check the locking condition of the coupler.</li> <li>• If there is a malfunction, repair it and connect the coupler securely.</li> </ul>	Set the main switch to "ON".	
2	Open or short circuit in wire harness.	<ul style="list-style-type: none"> <li>• Repair or replace if there is an open or short circuit.</li> <li>• Between throttle body sensor assembly coupler and ECU coupler. (gray/red–gray/red) (pink/white–pink/white) (gray/black–gray/black)</li> </ul>		
3	Defective throttle body sensor assembly (intake air pressure sensor).	<ul style="list-style-type: none"> <li>• Execute the diagnostic mode. (Code No.D03)</li> <li>• Replace the throttle body if defective. Refer to "CHECKING THE THROTTLE BODY SENSOR ASSEMBLY" on page 8-75.</li> </ul> <p><small>ECA22B1014</small></p> <p><b>NOTICE</b> _____</p> <p><b>Do not remove the throttle body sensor assembly from the throttle body.</b></p>		

<b>Fault code No.</b>	14	<b>Symptom</b>	Throttle body malfunction (clogged intake air pressure sensor hole or improperly installed throttle body sensor assembly). Intake air system malfunction (correct pressure is not supplied to throttle body sensor assembly)	
<b>Diagnostic code No.</b>	D03	Intake air pressure sensor		
<b>Order</b>	<b>Item/components and probable cause</b>		<b>Check or maintenance job</b>	<b>Reinstatement method</b>
1	Connections <ul style="list-style-type: none"> <li>• Throttle body sensor assembly coupler</li> <li>• Wire harness ECU coupler</li> </ul>		<ul style="list-style-type: none"> <li>• Check the coupler for any pins that may have pulled out.</li> <li>• Check the locking condition of the coupler.</li> <li>• If there is a malfunction, repair it and connect the coupler securely.</li> </ul>	Start the engine and let it run at idle.
2	Defective throttle body sensor assembly (intake air pressure sensor).		<ul style="list-style-type: none"> <li>• Execute the diagnostic mode. (Code No.D03)</li> <li>• Replace the throttle body if defective. Refer to “CHECKING THE THROTTLE BODY SENSOR ASSEMBLY” on page 8-75.</li> </ul> <p style="font-size: small; margin: 0;">ECA22B1014</p> <p><b>NOTICE</b></p> <p><b>Do not remove the throttle body sensor assembly from the throttle body.</b></p>	

<b>Fault code No.</b>	15	<b>Symptom</b>	<b>Throttle position sensor: open or short circuit detected.</b>					
<b>Diagnostic code No.</b>	D01	<b>Throttle position sensor</b>						
<b>Order</b>	<b>Item/components and probable cause</b>		<b>Check or maintenance job</b>					
1	Connections <ul style="list-style-type: none"> <li>• Throttle body sensor assembly coupler</li> <li>• Wire harness ECU coupler</li> </ul>		<ul style="list-style-type: none"> <li>• Check the coupler for any pins that may have pulled out.</li> <li>• Check the locking condition of the coupler.</li> <li>• If there is a malfunction, repair it and connect the coupler securely.</li> </ul>					
					Set the main switch to "ON".			
							2	
3								
		Throttle position sensor lead wire open circuit output voltage check. <ul style="list-style-type: none"> <li>• Check for open circuit and replace the throttle body. (gray/red-gray/black)</li> </ul>						
				Open circuit item	Output voltage			
				Ground wire open circuit	5 V			
Output wire open circuit	0 V							
4	Defective throttle body sensor assembly (throttle position sensor).		<ul style="list-style-type: none"> <li>• Execute the diagnostic mode. (Code No.D01)</li> <li>• Replace the throttle body if defective.</li> </ul> Refer to "CHECKING THE THROTTLE BODY SENSOR ASSEMBLY" on page 8-75.					
					<small>ECA22B1014</small> <b>NOTICE</b> Do not remove the throttle body sensor assembly from the throttle body.			



<b>Fault code No.</b>	16	<b>Symptom</b>	Stuck throttle position sensor detected.	
<b>Diagnostic code No.</b>	D01	Throttle position sensor		
<b>Order</b>	<b>Item/components and probable cause</b>		<b>Check or maintenance job</b>	<b>Reinstatement method</b>
1	Defective throttle body sensor assembly (throttle position sensor).		<ul style="list-style-type: none"> <li>Execute the diagnostic mode. (Code No.D01)</li> <li>Replace the throttle body if defective.</li> </ul> Refer to "CHECKING THE THROTTLE BODY SENSOR ASSEMBLY" on page 8-75. <small>ECA22B1014</small> <b>NOTICE</b> Do not remove the throttle body sensor assembly from the throttle body.	Start the engine, let it run at idle, and then race it.

<b>Fault code No.</b>	19	<b>Symptom</b>	A break or disconnection of the blue/yellow lead of the ECU is detected.	
<b>Diagnostic code No.</b>	D20	Sidestand switch		
<b>Order</b>	<b>Item/components and probable cause</b>		<b>Check or maintenance job</b>	<b>Reinstatement method</b>
1	Connections • Wire harness ECU coupler		<ul style="list-style-type: none"> <li>Execute the diagnostic mode. (Code No.D20)</li> <li>Check the coupler for any pins that may have pulled out.</li> <li>Check the locking condition of the coupler.</li> <li>If there is a malfunction, repair it and connect the coupler securely.</li> </ul>	Reconnect the wiring and retract the sidestand.
2	Open or short circuit in wire harness.		<ul style="list-style-type: none"> <li>Repair or replace if there is an open or short circuit.</li> <li>Between ECU and blue/yellow lead.</li> </ul>	
3	Defective sidestand switch.		<ul style="list-style-type: none"> <li>Replace if defective.</li> </ul> Refer to "CHECKING THE SWITCHES" on page 8-61.	

<b>Fault code No.</b>	21	<b>Symptom</b>	Coolant temperature sensor: open or short circuit detected.	
<b>Diagnostic code No.</b>	D06	Coolant temperature sensor		
<b>Order</b>	<b>Item/components and probable cause</b>		<b>Check or maintenance job</b>	<b>Reinstatement method</b>
1	Installed condition of coolant temperature sensor		Check for looseness or pinching.	Set the main switch to "ON".
2	Connections <ul style="list-style-type: none"> <li>• Coolant temperature sensor coupler</li> <li>• Wire harness ECU coupler</li> </ul>		<ul style="list-style-type: none"> <li>• Check the coupler for any pins that may have pulled out.</li> <li>• Check the locking condition of the coupler.</li> <li>• If there is a malfunction, repair it and connect it securely.</li> </ul>	
3	Open or short circuit in wire harness.		<ul style="list-style-type: none"> <li>• Repair or replace if there is an open or short circuit.</li> <li>• Between coolant temperature sensor coupler and ECU coupler. (gray/black–gray/black) (green/red–green/red)</li> </ul>	
4	Defective coolant temperature sensor.		<ul style="list-style-type: none"> <li>• Execute the diagnostic mode. (Code No.D06)</li> <li>• Replace if defective. Refer to "CHECKING THE COOLANT TEMPERATURE SENSOR" on page 8-75.</li> </ul>	

<b>Fault code No.</b>	22	<b>Symptom</b>	Intake air temperature sensor: open or short circuit detected.	
<b>Diagnostic code No.</b>	D05	Intake air temperature sensor		
<b>Order</b>	<b>Item/components and probable cause</b>		<b>Check or maintenance job</b>	<b>Reinstatement method</b>
1	Connections <ul style="list-style-type: none"> <li>• Throttle body sensor assembly coupler</li> <li>• Wire harness ECU coupler</li> </ul>		<ul style="list-style-type: none"> <li>• Check the couplers for any pins that may have pulled out.</li> <li>• Check the locking condition of the couplers.</li> <li>• If there is a malfunction, repair it and connect the coupler securely.</li> </ul>	Set the main switch to "ON".
2	Open or short circuit in wire harness.		<ul style="list-style-type: none"> <li>• Repair or replace if there is an open or short circuit.</li> <li>• Between throttle body sensor assembly coupler and ECU coupler. (brown/white–brown/white) (gray/black–gray/black)</li> </ul>	
3	Defective throttle body sensor assembly (intake air temperature sensor).		<ul style="list-style-type: none"> <li>• Execute the diagnostic mode. (Code No.D05)</li> <li>• Replace the throttle body if defective. Refer to "CHECKING THE THROTTLE BODY SENSOR ASSEMBLY" on page 8-75.</li> </ul> <p style="font-size: small; margin: 0;">ECA22B1014</p> <p><b>NOTICE</b> _____</p> <p><b>Do not remove the throttle body sensor assembly from the throttle body.</b></p>	

<b>Fault code No.</b>	30	<b>Symptom</b>	<b>Latch up detected. No normal signal is received from the lean angle sensor.</b>	
<b>Diagnostic code No.</b>	D08	<b>Lean angle sensor</b>		
<b>Order</b>	<b>Item/components and probable cause</b>		<b>Check or maintenance job</b>	<b>Reinstatement method</b>
1	The vehicle has overturned.		Raise the vehicle upright.	Set the main switch to "ON" (however, the engine cannot be restarted unless the main switch is first set to "OFF").
2	Installed condition of the lean angle sensor.		Check for looseness or pinching.	
3	Connections <ul style="list-style-type: none"> <li>• Lean angle sensor coupler</li> <li>• Wire harness ECU coupler</li> </ul>		<ul style="list-style-type: none"> <li>• Check the coupler for any pins that may have pulled out.</li> <li>• Check the locking condition of the coupler.</li> <li>• If there is a malfunction, repair it and connect the coupler securely.</li> </ul>	
4	Defective lean angle sensor.		<ul style="list-style-type: none"> <li>• Execute the diagnostic mode. (Code No.D08)</li> <li>• Replace if defective. Refer to "CHECKING THE LEAN ANGLE SENSOR" on page 8-71.</li> </ul>	

Order	Item/components and probable cause	Check or maintenance job	Reinstatement method
Fault code No. 33		Symptom Primary lead of the ignition coil: open circuit detected.	
Diagnostic code No. D30		Ignition coil	
1	Connections <ul style="list-style-type: none"> <li>• Ignition coil connector (primary coil end)</li> <li>• Wire harness ECU coupler</li> </ul>	<ul style="list-style-type: none"> <li>• Check the connector and coupler for any pins that may have pulled out.</li> <li>• Check the locking condition of the connector and coupler.</li> <li>• If there is a malfunction, repair it and connect the coupler securely.</li> </ul>	Start the engine and let it run at idle.
2	Open circuit in wire harness.	<ul style="list-style-type: none"> <li>• Repair or replace if there is an open circuit.</li> <li>• Between ignition coil connector and ECU coupler. (orange–orange)</li> <li>• Between ignition coil connector and engine stop switch coupler. (red/white–red/white)</li> <li>• Between engine stop switch coupler and ECU coupler. (red/black–red/black)</li> </ul>	
3	Defective ignition coil.	<ul style="list-style-type: none"> <li>• Execute the diagnostic mode. (Code No.D30)</li> <li>• Test the primary and secondary coils for continuity.</li> <li>• Replace if defective. Refer to “CHECKING THE IGNITION COIL” on page 8-70.</li> </ul>	

Order	Item/components and probable cause	Check or maintenance job	Reinstatement method
Fault code No. 39		Symptom Fuel injector: open or short circuit detected.	
Diagnostic code No. D36		Fuel injector	
1	Connections <ul style="list-style-type: none"> <li>• Fuel injector coupler</li> <li>• Wire harness ECU coupler</li> </ul>	<ul style="list-style-type: none"> <li>• Check the couplers for any pins that may have pulled out.</li> <li>• Check the locking condition of the couplers.</li> <li>• If there is a malfunction, repair it and connect the coupler securely.</li> </ul>	Start the engine.
2	Open or short circuit in wire harness.	<ul style="list-style-type: none"> <li>• Repair or replace if there is an open or short circuit.</li> <li>• Between fuel injector coupler and ECU coupler. (orange/black–orange/black)</li> <li>• Between fuel injection coupler and engine stop switch coupler. (red/white–red/white)</li> <li>• Between engine stop switch coupler and ECU coupler. (red/black–red/black)</li> </ul>	
3	Defective fuel injector.	<ul style="list-style-type: none"> <li>• Execute the diagnostic mode. (Code No.D36)</li> <li>• Replace if defective. Refer to “CHECKING THE FUEL INJECTOR” on page 7-7.</li> </ul>	

<b>Fault code No.</b>	41	<b>Symptom</b>	Lean angle sensor: open or short circuit detected.	
<b>Diagnostic code No.</b>	D08	Lean angle sensor		
<b>Order</b>	<b>Item/components and probable cause</b>		<b>Check or maintenance job</b>	<b>Reinstatement method</b>
1	Connections <ul style="list-style-type: none"> <li>• Lean angle sensor coupler</li> <li>• Wire harness ECU coupler</li> </ul>		<ul style="list-style-type: none"> <li>• Check the coupler for any pins that may have pulled out.</li> <li>• Check the locking condition of the coupler.</li> <li>• If there is a malfunction, repair it and connect the coupler securely.</li> </ul>	Set the main switch to "ON".
2	Open or short circuit in wire harness.		<ul style="list-style-type: none"> <li>• Repair or replace if there is an open or short circuit.</li> <li>• Between lean angle sensor coupler and ECU coupler. (gray/red–gray/red) (yellow/green–yellow/green) (gray/black–gray/black)</li> </ul>	
3	Defective lean angle sensor.		<ul style="list-style-type: none"> <li>• Execute the diagnostic mode. (Code No.D08)</li> <li>• Replace if defective. Refer to "CHECKING THE LEAN ANGLE SENSOR" on page 8-71.</li> </ul>	

<b>Fault code No.</b>	42	<b>Symptom</b>	No normal signals are received from the speed sensor.	
<b>Diagnostic code No.</b>	D07	<b>Speed sensor</b>		
<b>Order</b>	<b>Item/components and probable cause</b>		<b>Check or maintenance job</b>	<b>Reinstatement method</b>
1	Connections <ul style="list-style-type: none"> <li>• Speed sensor coupler</li> <li>• Wire harness ECU coupler</li> </ul>		<ul style="list-style-type: none"> <li>• Check the coupler for any pins that may have pulled out.</li> <li>• Check the locking condition of the coupler.</li> <li>• If there is a malfunction, repair it and connect the coupler securely.</li> </ul>	Start the engine, and input the vehicle speed signals by operating the vehicle at 20 to 30 km/h.
2	Open or short circuit in wire harness.		<ul style="list-style-type: none"> <li>• Repair or replace if there is an open or short circuit.</li> <li>• Between speed sensor coupler and ECU coupler. (gray-gray) (gray/black-gray/black) (gray/red-gray/red)</li> </ul>	
3	Defective speed sensor.		<ul style="list-style-type: none"> <li>• Execute the diagnostic mode. (Code No.D07)</li> <li>• Replace if defective. Refer to "CHECKING THE SPEED SENSOR" on page 8-74.</li> </ul>	

<b>Fault code No.</b>	44	<b>Symptom</b>	Error is detected while reading from or writing on EEPROM.	
<b>Diagnostic code No.</b>	D60	<b>EEPROM fault code display</b>		
<b>Order</b>	<b>Item/components and probable cause</b>		<b>Check or maintenance job</b>	<b>Reinstatement method</b>
1	Malfunction in ECU.		<ul style="list-style-type: none"> <li>• Execute the diagnostic mode. (Code No.D60)</li> <li>• If "01" is displayed, readjust the CO. Refer to "ADJUSTING THE EXHAUST GAS VOLUME" on page 3-5.</li> <li>• Replace ECU if defective.</li> </ul> <p><b>TIP</b> _____ Do not replace the ECU with the main switch set to "ON".</p>	Set the main switch to "ON".



<b>Fault code No.</b>	46	<b>Symptom</b>	Power supply to the fuel injection system is not normal.	
<b>Diagnostic code No.</b>	—		—	
<b>Order</b>	<b>Item/components and probable cause</b>		<b>Check or maintenance job</b>	<b>Reinstatement method</b>
1	Connections • Wire harness ECU coupler		<ul style="list-style-type: none"> <li>• Check the coupler for any pins that may have pulled out.</li> <li>• Check the locking condition of the coupler.</li> <li>• If there is a malfunction, repair it and connect the coupler securely.</li> </ul>	Start the engine and let it run at idle.
2	Faulty battery.		<ul style="list-style-type: none"> <li>• Replace or charge the battery. Refer to “CHECKING AND CHARGING THE BATTERY” on page 8-65.</li> </ul>	
3	Malfunction in rectifier/regulator		<ul style="list-style-type: none"> <li>• Replace if defective. Refer to “CHECKING THE RECTIFIER/REGULATOR” on page 8-72.</li> </ul>	
4	Open or short circuit in wire harness.		<ul style="list-style-type: none"> <li>• Repair or replace if there is an open or short circuit.</li> <li>• Between battery and main fuse terminal. (red–red)</li> <li>• Between main fuse terminal and main switch coupler. (red–red)</li> <li>• Between main switch coupler and fuse box terminal (ignition fuse). (brown/blue–brown/blue)</li> <li>• Between fuse box terminal (ignition fuse) and ECU coupler. (red/black–red/black)</li> </ul>	

<b>Fault code No.</b>	50	<b>Symptom</b>	Faulty ECU memory. (When this malfunction is detected in the ECU, the fault code number might not appear on the FI diagnostic tool.)	
<b>Diagnostic code No.</b>	—		—	
<b>Order</b>	<b>Item/components and probable cause</b>		<b>Check or maintenance job</b>	<b>Reinstatement method</b>
1	Malfunction in ECU.		<ul style="list-style-type: none"> <li>• Replace the ECU.</li> </ul> <b>TIP</b> _____ Do not replace the ECU with the main switch set to “ON”. _____	Set the main switch to “ON”.



- 3. Main switch
- 5. Main fuse
- 6. Battery
- 14. Engine stop switch
- 22. ECU (engine control unit)
- 27. Fuel pump
- 60. Ignition fuse

EAS27570

## TROUBLESHOOTING

If the fuel pump fails to operate.

### TIP

• Before troubleshooting, remove the following part(s):

1. Battery cover
2. Fuel tank

<p>1. Check the fuses. (Main and ignition) Refer to "CHECKING THE FUSES" on page 8-65.</p>	<p>NG →</p>	<p>Replace the fuse(s).</p>
<p>OK ↓</p>		
<p>2. Check the battery. Refer to "CHECKING AND CHARGING THE BATTERY" on page 8-65.</p>	<p>NG →</p>	<ul style="list-style-type: none"> <li>• Refill battery fluid.</li> <li>• Clean the battery terminals.</li> <li>• Recharge or replace the battery.</li> </ul>
<p>OK ↓</p>		
<p>3. Check the main switch. Refer to "CHECKING THE SWITCHES" on page 8-61.</p>	<p>NG →</p>	<p>Replace the main switch.</p>
<p>OK ↓</p>		
<p>4. Check the engine stop switch. Refer to "CHECKING THE SWITCHES" on page 8-61.</p>	<p>NG →</p>	<p>The engine stop switch is faulty. Replace the right handlebar switch.</p>
<p>OK ↓</p>		
<p>5. Check the fuel pump operation. Refer to "CHECKING THE FUEL PRESSURE" on page 7-3.</p>	<p>NG →</p>	<p>Replace the fuel pump.</p>
<p>OK ↓</p>		
<p>6. Check the entire fuel pump system wiring. Refer to "CIRCUIT DIAGRAM" on page 8-55.</p>	<p>NG →</p>	<p>Properly connect or repair the fuel pump system wiring.</p>
<p>OK ↓</p>		
<p>Replace the ECU.</p>		



EAS27972

ELECTRICAL COMPONENTS

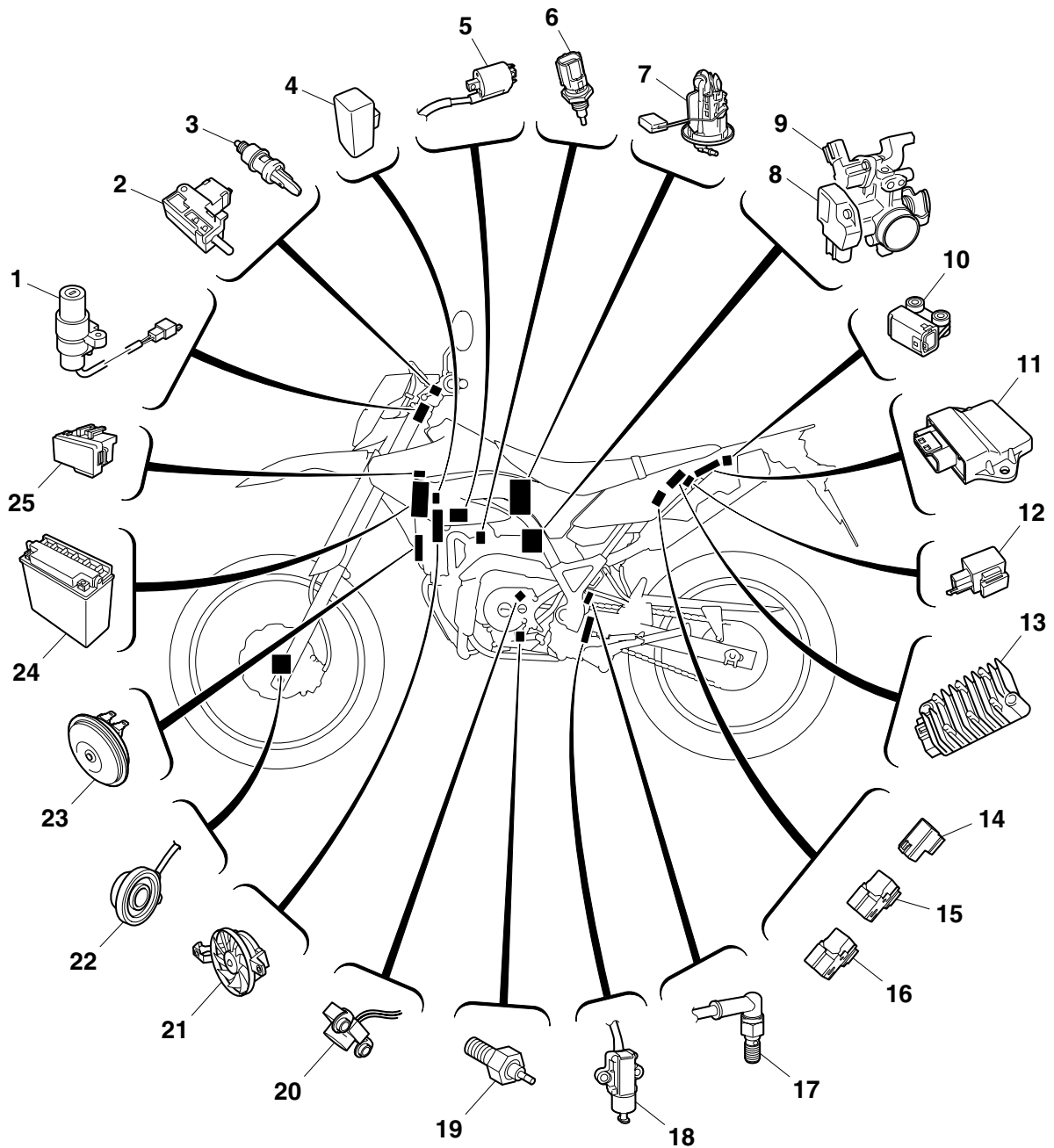

1. Main switch
2. Clutch switch
3. Front brake light switch
4. Starter relay
5. Ignition coil
6. Coolant temperature sensor
7. Fuel pump assembly
8. Throttle body sensor assembly (intake air pressure sensor, intake air temperature sensor, throttle position sensor)
9. FID (fast idle solenoid)
10. Lean angle sensor
11. ECU (engine control unit)
12. Turn signal relay
13. Rectifier/regulator
14. Headlight relay
15. Radiator fan motor relay
16. Starting circuit cut-off relay
17. Rear brake light switch
18. Sidestand switch
19. Neutral switch
20. Crankshaft position sensor
21. Radiator fan
22. Speed sensor
23. Horn
24. Battery
25. Fuse box

EAS27980

## CHECKING THE SWITCHES

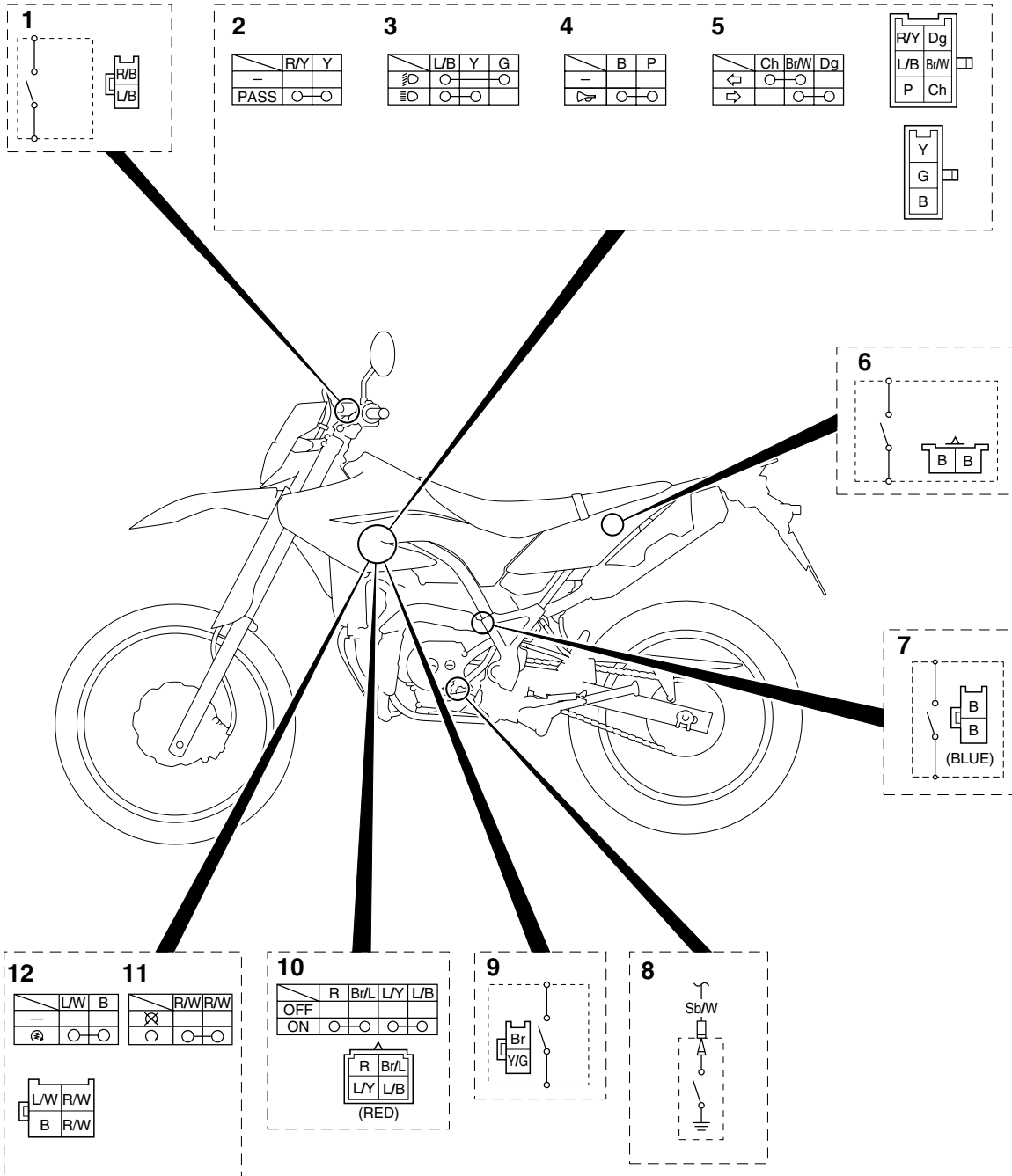



1. Clutch switch
2. Pass switch
3. Dimmer switch
4. Horn switch
5. Turn signal switch
6. Rear brake light switch
7. Sidestand switch
8. Neutral switch
9. Front brake light switch
10. Main switch
11. Engine stop switch
12. Start switch

Check each switch for continuity with the pocket tester. If the continuity reading is incorrect, check the wiring connections and, if necessary, replace the switch.

ECA14370

**NOTICE**

Never insert the tester probes into the coupler terminal slots "a". Always insert the probes from the opposite end of the coupler, taking care not to loosen or damage the leads.

	<p><b>Pocket tester</b>  <b>90890-03112</b>  <b>Analog pocket tester</b>  <b>YU-03112-C</b></p>
---	---

**TIP**

- Before checking for continuity, set the pocket tester to "0" and to the " $\Omega \times 1$ " range.
- When checking for continuity, switch back and forth between the switch positions a few times.

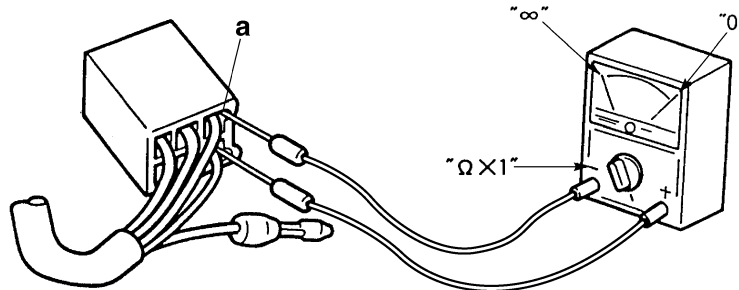

The switches and their terminal connections are illustrated as in the following example of the main switch.

The switch positions "a" are shown in the far left column and the switch lead colors "b" are shown in the top row.

The continuity (i. e., a closed circuit) between switch terminals at a given switch position is indicated by "○—○". There is continuity between red and brown/blue, and blue/yellow and blue/black when the switch is set to "ON".

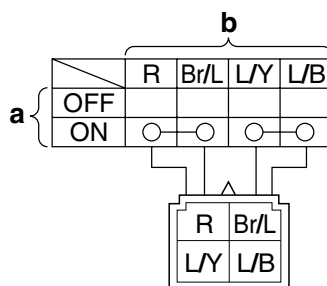



### Checking the condition of the bulb sockets

The following procedure applies to all of the bulb sockets.

1. Check:
  - Bulb socket (for continuity) (with the pocket tester)  
No continuity → Replace.

	<b>Pocket tester</b> <b>90890-03112</b> <b>Analog pocket tester</b> <b>YU-03112-C</b>
---	--

**TIP**

Check each bulb socket for continuity in the same manner as described in the bulb section, however, note the following.

- a. Install a good bulb into the bulb socket.
- b. Connect the pocket tester probes to the respective leads of the bulb socket.
- c. Check the bulb socket for continuity. If any of the readings indicate no continuity, replace the bulb socket.

EAS28000

### CHECKING THE FUSES

The following procedure applies to all of the fuses.

ECA22B1016

**NOTICE**

**To avoid a short circuit, always set the main switch to “OFF” when checking or replacing a fuse.**

1. Remove:
  - Battery cover  
Refer to “GENERAL CHASSIS” on page 4-1.
2. Check:
  - Fuse

- a. Connect the pocket tester to the fuse and check the continuity.

**TIP**

Set the pocket tester selector to “Ω × 1”.

	<b>Pocket tester</b> <b>90890-03112</b> <b>Analog pocket tester</b> <b>YU-03112-C</b>
---	--

- b. If the pocket tester indicates “∞”, replace the fuse.

3. Replace:
  - Blown fuse

- a. Set the main switch to “OFF”.
- b. Install a new fuse of the correct amperage rating.
- c. Set on the switches to verify if the electrical circuit is operational.
- d. If the fuse immediately blows again, check the electrical circuit.

Item	Amperage rating	Q'ty
Main	20 A	1
Headlight	15 A	1
Ignition	7.5 A	1
Signaling system	7.5 A	1
Radiator fan motor	5 A	1
Spare	20 A	1
Spare	15 A	1
Spare	7.5 A	1
Spare	5 A	1

EWA13310

**WARNING**

**Never use a fuse with an amperage rating other than that specified. Improvising or using a fuse with the wrong amperage rating may cause extensive damage to the electrical system, cause the lighting and ignition systems to malfunction and could possibly cause a fire.**

4. Install:
  - Battery cover  
Refer to “GENERAL CHASSIS” on page 4-1.

EAS28010

### CHECKING AND CHARGING THE BATTERY

EWA13290

**WARNING**

**Batteries generate explosive hydrogen gas and contain electrolyte which is made of poisonous and highly caustic sulfuric acid. Therefore, always follow these preventive measures:**

- Wear protective eye gear when handling or working near batteries.
- Charge batteries in a well-ventilated area.
- Keep batteries away from fire, sparks or open flames (e.g., welding equipment, lighted cigarettes).

- **DO NOT SMOKE** when charging or handling batteries.
- **KEEP BATTERIES AND ELECTROLYTE OUT OF REACH OF CHILDREN.**
- **Avoid bodily contact with electrolyte** as it can cause severe burns or permanent eye injury.

### FIRST AID IN CASE OF BODILY CONTACT: EXTERNAL

- **Skin** — Wash with water.
- **Eyes** — Flush with water for 15 minutes and get immediate medical attention.

### INTERNAL

- **Drink large quantities of water or milk** followed with milk of magnesia, beaten egg or vegetable oil. Get immediate medical attention.

### 1. Remove:

- Battery cover  
Refer to "GENERAL CHASSIS" on page 4-1.

### 2. Disconnect:

- Battery leads  
(from the battery terminals)

ECA22B1017

### NOTICE

**First, disconnect the negative battery lead "1", then the positive battery lead "2".**

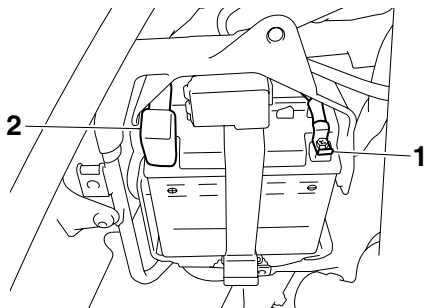

### 3. Remove:

- Battery

### 4. Disconnect:

- Battery breather hose

### 5. Check:

- Electrolyte level

The electrolyte level should be between the minimum level mark "a" and the maximum level mark "b".

Below the minimum level mark → Add distilled water to the proper level.

ECA13610

### NOTICE

**Add only distilled water. Tap water contains minerals which are harmful to the battery.**

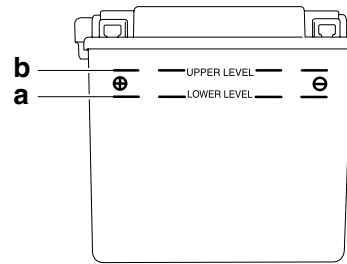

### 6. Check:

- Specific gravity  
Less than 1.280 → Recharge the battery.



**Specific gravity**  
1.280 at 20 °C (68 °F)

### 7. Charge:

- Battery

Battery charging amperage and time  
5.5 A/10 hrs

EWA13300

### WARNING

**Do not quick charge a battery.**

ECA13620

### NOTICE

- **Loosen the battery sealing caps.**
- **Make sure the battery breather hose and battery vent are free of obstructions.**
- **To ensure maximum performance, always charge a new battery before using it.**
- **Do not use a high-rate battery charger. They force a high-amperage current into the battery quickly and can cause battery overheating and battery plate damage.**
- **If it is impossible to regulate the charging current on the battery charger, be careful not to overcharge the battery.**
- **When charging a battery, be sure to remove it from the vehicle. (If charging has to be done with the battery mounted on the vehicle, disconnect the negative lead from the battery terminal.)**
- **To reduce the chance of sparks, do not plug in the battery charger until the battery charger leads are connected to the battery.**
- **Before removing the battery charger lead clips from the battery terminals, be sure to turn off the battery charger.**
- **Make sure the battery charger lead clips are in full contact with the battery terminal and that they are not shorted. A corroded bat-**

tery charger lead clip may generate heat in the contact area and a weak clip spring may cause sparks.

- If the battery becomes hot to the touch at any time during the charging process, disconnect the battery charger and let the battery cool before reconnecting it. Hot batteries can explode!

### TIP

Replace the battery whenever:

- battery voltage does not rise to specification or bubbles fail to rise during charging,
- sulphation of one or more battery cells occurs (as indicated by the battery plates turning white or material accumulating in the bottom of the battery cell),
- specific gravity readings after a long, slow charge indicate that one battery cell's charge is lower than the rest,
- warpage or buckling of the battery plates or insulators is evident.

### 8. Check:

- Battery breather hose and battery vent  
Obstruction → Clean.  
Damage → Replace.

### 9. Connect:

- Battery breather hose "1"

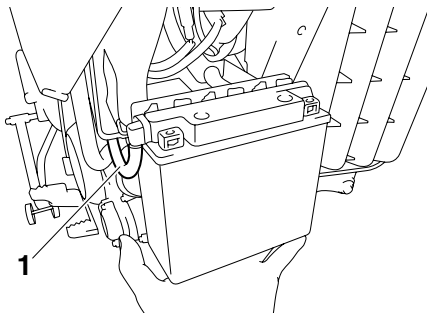

ECA22B1018

### NOTICE

When checking the battery, make sure the battery breather hose is properly installed and routed correctly. If the battery breather hose is positioned so as to allow electrolyte or hydrogen gas from the battery to contact the frame, the vehicle and its finish may be damaged. Refer to "CABLE ROUTING" on page 2-35.

### 10. Install:

- Battery

### 11. Check:

- Battery terminals  
Dirt → Clean with a wire brush.

Loose connection → Connect properly.

### 12. Connect:

- Battery leads  
(to the battery terminals)

ECA22B1019

### NOTICE

First, connect the positive battery lead "1", then the negative battery lead "2".

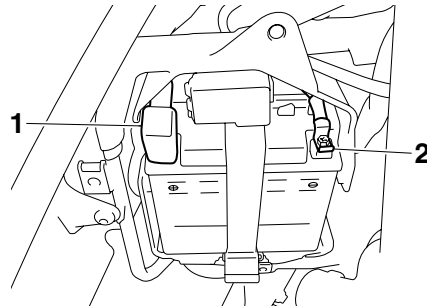

### 13. Lubricate:

- Battery terminals



**Recommended lubricant**  
**Dielectric grease**

### 14. Install:

- Battery cover  
Refer to "GENERAL CHASSIS" on page 4-1.

EAS28040

### CHECKING THE RELAYS

Check each switch for continuity with the pocket tester. If the continuity reading is incorrect, replace the relay.

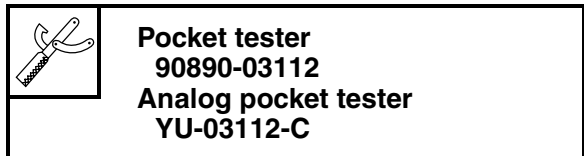

**Pocket tester**  
**90890-03112**  
**Analog pocket tester**  
**YU-03112-C**

1. Disconnect the relay from the wire harness.
2. Connect the pocket tester ( $\Omega \times 1$ ) and battery (12 V) to the relay terminal as shown. Check the relay operation.  
Out of specification → Replace.

## Starter relay

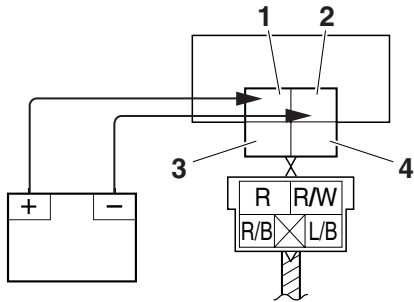

1. Positive battery terminal
2. Negative battery terminal
3. Positive tester probe
4. Negative tester probe



**Result**  
**Continuity**  
(between “3” and “4”)

## Starting circuit cut-off relay

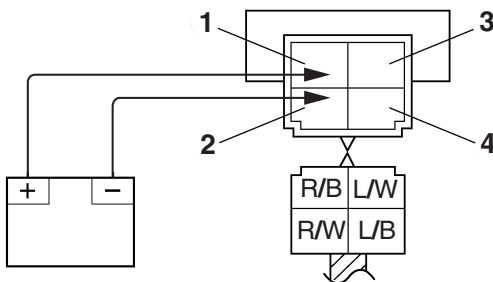

1. Positive battery terminal
2. Negative battery terminal
3. Positive tester probe
4. Negative tester probe



**Result**  
**Continuity**  
(between “3” and “4”)

## Headlight relay

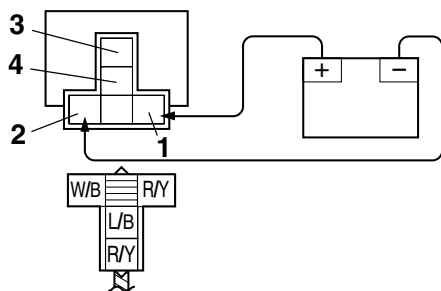

1. Positive battery terminal

2. Negative battery terminal
3. Positive tester probe
4. Negative tester probe



**Result**  
**Continuity**  
(between “3” and “4”)

## Radiator fan motor relay

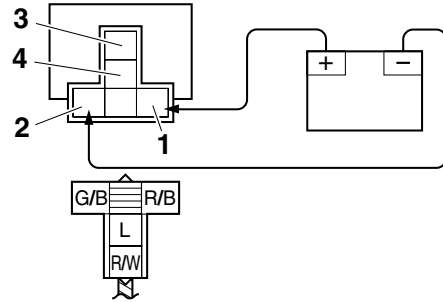

1. Positive battery terminal
2. Negative battery terminal
3. Positive tester probe
4. Negative tester probe



**Result**  
**Continuity**  
(between “3” and “4”)

EAS22B1024

## CHECKING THE TURN SIGNAL RELAY

1. Check:
  - Turn signal relay input voltage  
Out of specification → The wiring circuit from the main switch to the turn signal relay coupler is faulty and must be repaired.



**Turn signal relay input voltage**  
**DC 12 V**

- a. Connect the pocket tester (DC 20 V) to the turn signal relay terminal as shown.



**Pocket tester**  
**90890-03112**  
**Analog pocket tester**  
**YU-03112-C**

- Positive tester probe → brown “1”
- Negative tester probe → ground

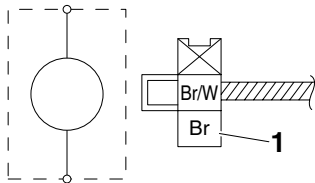

- b. Set the main switch to "ON".
- c. Measure the turn signal relay input voltage.



- 2. Check:
  - Turn signal relay output voltage
  - Out of specification → Replace.

**Turn signal relay output voltage**  
DC 12 V



- a. Connect the pocket tester (DC 20 V) to the turn signal relay terminal as shown.

**Pocket tester**  
90890-03112  
**Analog pocket tester**  
YU-03112-C

- Positive tester probe → brown/white "1"
- Negative tester probe → ground

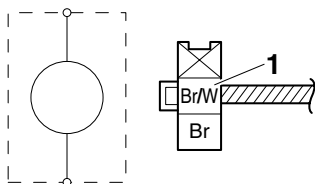

- b. Set the main switch to "ON".
- c. Measure the turn signal relay output voltage.



EAS28050  
**CHECKING THE DIODE**

- 1. Check:
  - Diode
  - Out of specification → Replace.

**Pocket tester**  
90890-03112  
**Analog pocket tester**  
YU-03112-C

**TIP**

The pocket tester or the analog pocket tester readings are shown in the following table.

**No continuity**  
Positive tester probe → blue/black "1"  
Negative tester probe → sky blue/white "2"

**Continuity**  
Positive tester probe → sky blue/white "2"  
Negative tester probe → blue/black "1"

**No continuity**  
Positive tester probe → red/black "3"  
Negative tester probe → sky blue/white "2"

**Continuity**  
Positive tester probe → sky blue/white "2"  
Negative tester probe → red/black "3"

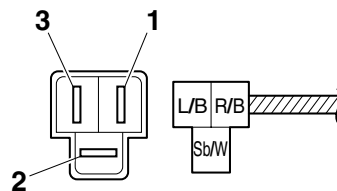

- a. Disconnect the diode from the wire harness.
- b. Connect the pocket tester ( $\Omega \times 1$ ) to the diode terminals as shown.
- c. Check the diode for continuity.
- d. Check the diode for no continuity.



EAS28060  
**CHECKING THE SPARK PLUG CAP**

- 1. Check:
  - Spark plug cap resistance
  - Out of specification → Replace.



	<b>Resistance</b> 5.0 k $\Omega$
---	-------------------------------------

- a. Remove the spark plug cap from the spark plug lead.
- b. Connect the pocket tester ( $\Omega \times 1k$ ) to the spark plug cap as shown.

	<b>Pocket tester</b> 90890-03112 <b>Analog pocket tester</b> YU-03112-C
---	--

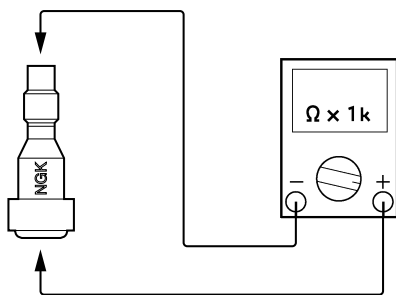

- c. Measure the spark plug cap resistance.

EAS28090

### CHECKING THE IGNITION COIL

1. Check:
  - Primary coil resistance  
Out of specification  $\rightarrow$  Replace.

	<b>Primary coil resistance</b> 2.16–2.64 $\Omega$ at 20 $^{\circ}$ C (68 $^{\circ}$ F)
---	---

- a. Disconnect the ignition coil connectors from the ignition coil terminals.
- b. Connect the pocket tester ( $\Omega \times 1$ ) to the ignition coil as shown.

	<b>Pocket tester</b> 90890-03112 <b>Analog pocket tester</b> YU-03112-C
---	--

- Positive tester probe  $\rightarrow$  red/white "1"
- Negative tester probe  $\rightarrow$  orange "2"

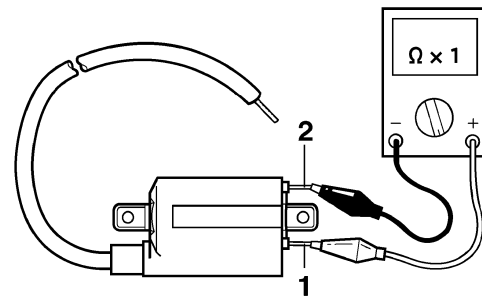

- c. Measure the primary coil resistance.

2. Check:
  - Secondary coil resistance  
Out of specification  $\rightarrow$  Replace.

	<b>Secondary coil resistance</b> 8.64–12.96 k $\Omega$ at 20 $^{\circ}$ C (68 $^{\circ}$ F)
---	--

- a. Disconnect the spark plug cap from the ignition coil.
- b. Connect the pocket tester ( $\Omega \times 1k$ ) to the ignition coil as shown.

	<b>Pocket tester</b> 90890-03112 <b>Analog pocket tester</b> YU-03112-C
---	--

- Positive tester probe  $\rightarrow$  orange "1"
- Negative tester probe  $\rightarrow$  spark plug lead "2"

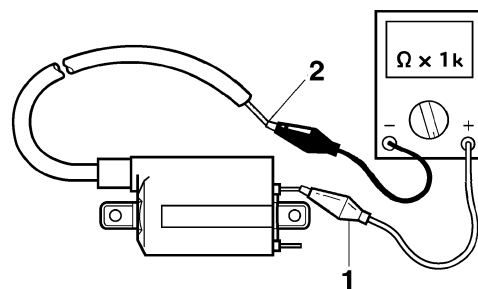

- c. Measure the secondary coil resistance.

EAS28930

### CHECKING THE IGNITION SPARK GAP

1. Check:
  - Ignition spark gap  
Out of specification  $\rightarrow$  Perform the ignition system troubleshooting, starting with step 5.

Refer to "TROUBLESHOOTING" on page 8-3.



**Minimum ignition spark gap  
6.0 mm (0.24 in)**

### TIP

If the ignition spark gap is within specification, the ignition system circuit is operating normally.



- a. Disconnect the spark plug cap from the spark plug.
- b. Connect the ignition checker "1" as shown.



**Ignition checker  
90890-06754  
Opama pet-4000 spark checker  
YM-34487**

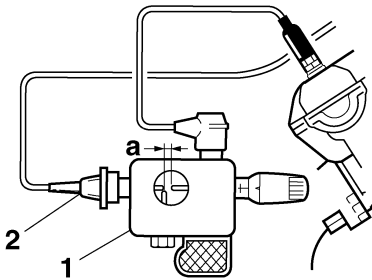

2. Spark plug cap
- c. Set the main switch to "ON" and the engine stop switch to "O".
- d. Measure the ignition spark gap "a".
- e. Crank the engine by pushing the start switch "⊗" and gradually increase the spark gap until a misfire occurs.



EAS28120

### CHECKING THE CRANKSHAFT POSITION SENSOR

1. Disconnect:
  - Crankshaft position sensor coupler (from the wire harness)
2. Check:
  - Crankshaft position sensor resistance  
Out of specification → Replace the crankshaft position sensor/stator assembly.



**Crankshaft position sensor resistance  
248–372 Ω at 20 °C (68 °F)**

- a. Connect the pocket tester ( $\Omega \times 100$ ) to the crankshaft position sensor coupler as shown.



**Pocket tester  
90890-03112  
Analog pocket tester  
YU-03112-C**

- Positive tester probe → red "1"
- Negative tester probe → white "2"

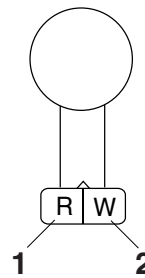

- b. Measure the crankshaft position sensor resistance.



EAS28130

### CHECKING THE LEAN ANGLE SENSOR

1. Remove:
  - Lean angle sensor
2. Check:
  - Lean angle sensor output voltage  
Out of specification → Replace.



**Lean angle sensor output voltage  
Less than 65°: 0.4–1.4 V  
More than 65°: 3.7–4.4 V**



- a. Connect the lean angle sensor to the wire harness.
- b. Connect the pocket tester (DC 20 V) to the lean angle sensor coupler as shown.



**Pocket tester  
90890-03112  
Analog pocket tester  
YU-03112-C**

- Positive tester probe → yellow/green "1"
- Negative tester probe → gray/black "2"

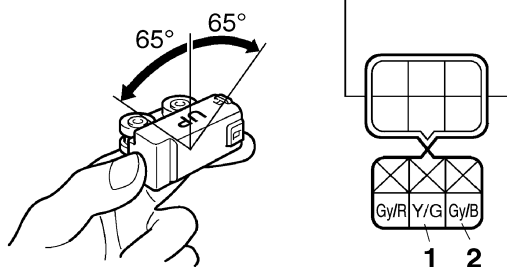

- c. Set the main switch to "ON".
- d. Tilt the lean angle sensor to 65°.
- e. Measure the lean angle sensor output voltage.



EAS28940

### CHECKING THE STARTER MOTOR OPERATION

1. Check:
  - Starter motor operation  
Does not operate → Perform the electric starting system troubleshooting, starting with step 4.  
Refer to "TROUBLESHOOTING" on page 8-8.



- a. Connect the positive battery terminal "1" and starter motor lead "2" with a jumper lead "3".

EWA13810

### **WARNING**

- A wire that is used as a jumper lead must have at least the same capacity of the battery lead, otherwise the jumper lead may burn.
- This check is likely to produce sparks, therefore, make sure no flammable gas or fluid is in the vicinity.

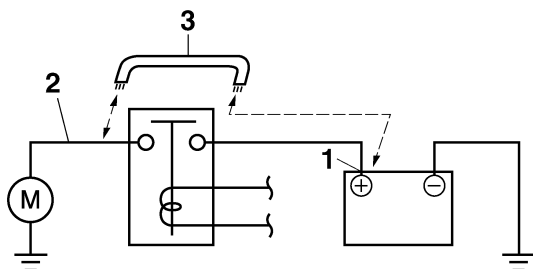

- b. Check the starter motor operation.



EAS28150

### CHECKING THE STATOR COIL

1. Disconnect:
  - Stator coil coupler (from the wire harness)
2. Check:
  - Stator coil resistance  
Out of specification → Replace the crankshaft position sensor/stator assembly.



**Stator coil resistance**  
**0.448–0.672 Ω at 20 °C (68 °F)**

- a. Connect the pocket tester ( $\Omega \times 1$ ) to the stator coil coupler as shown.



**Pocket tester**  
**90890-03112**  
**Analog pocket tester**  
**YU-03112-C**

- Positive tester probe → white "1"
- Negative tester probe → white "2"

- Positive tester probe → white "1"
- Negative tester probe → white "3"

- Positive tester probe → white "2"
- Negative tester probe → white "3"

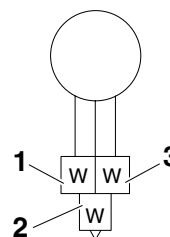

- b. Measure the stator coil resistance.



EAS28170

### CHECKING THE RECTIFIER/REGULATOR

1. Check:
  - Charging voltage  
Out of specification → Replace the rectifier/regulator.



**Charging voltage**  
14 V at 5000 r/min

- a. Set the engine tachometer to the spark plug lead.
- b. Connect the pocket tester (DC 20 V) to the rectifier/regulator coupler as shown.



**Pocket tester**  
90890-03112  
**Analog pocket tester**  
YU-03112-C

- Positive tester probe → red “1”
- Negative tester probe → ground

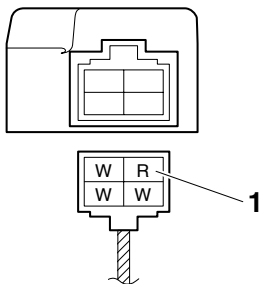

- c. Start the engine and let it run at approximately 5000 r/min.
- d. Measure the charging voltage.



EAS28180

## CHECKING THE HORN

1. Check:
  - Horn resistance  
Out of specification → Replace.



**Coil resistance**  
1.06–1.11 Ω at 20 °C (68 °F)

- a. Disconnect the horn connectors from the horn terminals.
- b. Connect the pocket tester ( $\Omega \times 1$ ) to the horn terminals.



**Pocket tester**  
90890-03112  
**Analog pocket tester**  
YU-03112-C

- Positive tester probe → horn terminal “1”
- Negative tester probe → horn terminal “2”

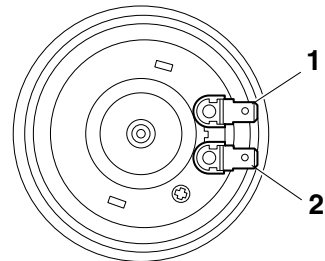

- c. Measure the horn resistance.



2. Check:
  - Horn sound  
Faulty sound → Adjust or replace.



- a. Connect a battery (12 V) to the horn.
- b. Turn the adjusting screw in direction “a” or “b” until the specified horn sound is obtained.

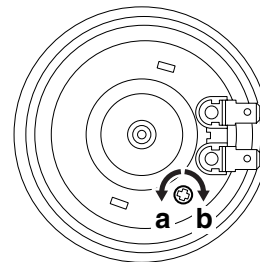

EAS28230

## CHECKING THE FUEL SENDER

1. Disconnect:
  - Fuel pump coupler
  - Fuel hose  
(from the fuel pump)
2. Remove:
  - Fuel tank
3. Remove:
  - Fuel pump assembly  
(from the fuel tank)
4. Check:
  - Fuel sender resistance  
Out of specification → Replace the fuel pump assembly.



**Sender unit resistance (full)**  
 19.0–21.0 Ω at 20 °C (68 °F)  
**Sender unit resistance (empty)**  
 137.0–143.0 Ω at 20 °C (68 °F)

a. Connect the pocket tester ( $\Omega \times 100$ ) to the fuel sender terminal as shown.



**Pocket tester**  
 90890-03112  
**Analog pocket tester**  
 YU-03112-C

- Positive tester probe → sky blue “1”
- Negative tester probe → orange/white “2”

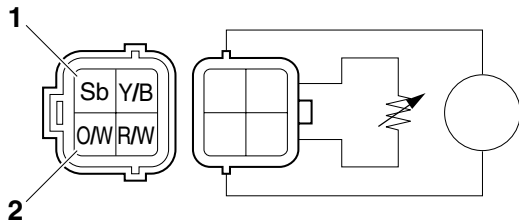

b. Move the fuel sender float to the empty fuel tank position “3” and to the full fuel tank position “4”.

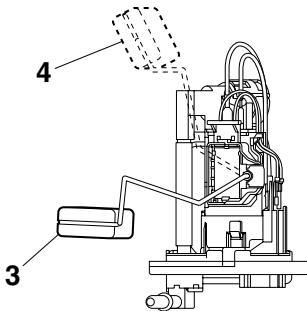

c. Measure the fuel sender resistance.

EAS28240

### CHECKING THE SPEED SENSOR

1. Check:
- Speed sensor output voltage  
 Out of specification → Replace.



**Output voltage reading cycle**  
 0.6 V to 4.8 V to 0.6 V to 4.8 V

a. Connect the pocket tester (DC 20 V) to the speed sensor coupler as shown.



**Pocket tester**  
 90890-03112  
**Analog pocket tester**  
 YU-03112-C

- Positive tester probe → gray “1”
- Negative tester probe → gray/black “2”

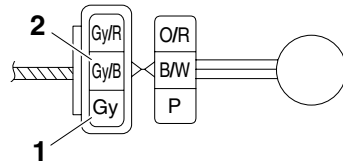

- b. Set the main switch to “ON”.
- c. Elevate the front wheel and slowly rotate it.
- d. Measure the voltage of gray and gray/black. With each full rotation of the front wheel, the voltage reading should cycle from 0.6 V to 4.8 V to 0.6 V to 4.8 V.

EAS28250

### CHECKING THE RADIATOR FAN MOTOR

1. Check:
- Radiator fan motor  
 Faulty/rough movement → Replace.

a. Disconnect the radiator fan motor coupler from the wire harness.

b. Connect the battery (DC 12 V) as shown.

- Positive tester probe → blue “1”
- Negative tester probe → black “2”

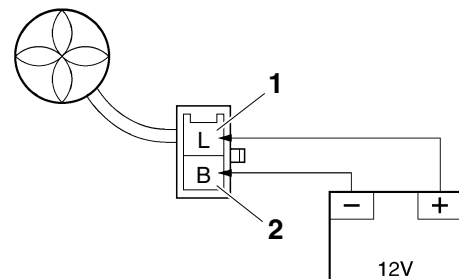

c. Measure the radiator fan motor movement.



EAS28260

## CHECKING THE COOLANT TEMPERATURE SENSOR

1. Remove:
  - Coolant temperature sensor

EWA14130

### WARNING

- Handle the coolant temperature sensor with special care.
- Never subject the coolant temperature sensor to strong shocks. If the coolant temperature sensor is dropped, replace it.

2. Check:
  - Coolant temperature sensor resistance  
Out of specification → Replace.

**Coolant temperature sensor resistance**  
 2.32–2.59 kΩ at 20 °C (68 °F)  
 310–326 Ω at 80 °C (176 °F)



- a. Connect the pocket tester ( $\Omega \times 100$ ) to the coolant temperature sensor terminals as shown.

**Pocket tester**  
 90890-03112  
**Analog pocket tester**  
 YU-03112-C

- b. Immerse the coolant temperature sensor “1” in a container filled with coolant “2”.

### TIP

Make sure the coolant temperature sensor terminals do not get wet.

- c. Place a thermometer “3” in the coolant.

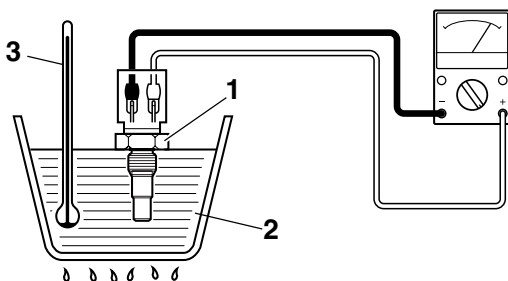

- d. Slowly heat the coolant, and then let it cool down to the specified temperature.

- e. Measure the coolant temperature sensor resistance.



3. Install:
  - Coolant temperature sensor

**Coolant temperature sensor**  
 18 Nm (1.8 m·kgf, 13 ft·lbf)

EAS22B1025

## CHECKING THE THROTTLE BODY SENSOR ASSEMBLY

EWA22B1002

### WARNING

- Do not remove the throttle body sensor assembly.
- Handle the throttle body sensor assembly with special care.
- Never subject the throttle body sensor assembly to strong shocks. If the throttle body sensor assembly is dropped, replace it.

### Throttle position sensor

1. Check:
  - Throttle position sensor



- a. Connect the digital circuit tester to the terminals of the throttle body sensor assembly coupler as shown.

**Digital circuit tester**  
 90890-03174  
**Model 88 Multimeter with tachometer**  
 YU-A1927

- Positive tester probe → gray/red terminal “1”
- Negative tester probe → gray/black terminal “2”

- b. Measure the throttle position sensor input voltage.  
Out of specification → Replace or repair the wire harness.

**Throttle position sensor input voltage**  
 5 V

- c. Connect the digital circuit tester to the terminals of the throttle body sensor assembly coupler as shown.

- Positive tester probe → yellow terminal “3”
- Negative tester probe → gray/black terminal “2”

d. While slowly opening the throttle, check that the throttle position sensor output voltage is increased.  
Voltage does not change or it changes abruptly → Replace the throttle body.  
Out of specification (closed position) → Replace the throttle body.



**Throttle position sensor output voltage (closed position)**  
**0.63–0.73 V**

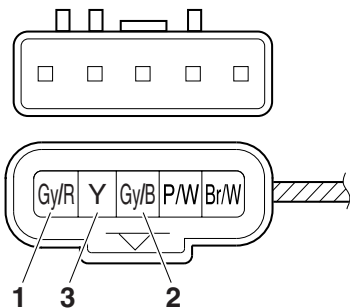

### Intake air pressure sensor

1. Check:
- Intake air pressure sensor output voltage  
Out of specification → Replace the throttle body.



**Intake air pressure sensor output voltage**  
**4.70–5.20 V**

a. Connect the pocket tester (DC 20 V) to the throttle body sensor assembly coupler as shown.



**Pocket tester**  
**90890-03112**  
**Analog pocket tester**  
**YU-03112-C**

- Positive tester probe → pink/white “1”
- Negative tester probe → gray/black “2”

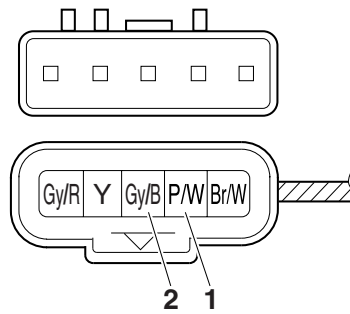

- b. Set the main switch to “ON”.  
c. Measure the intake air pressure sensor output voltage.

### Intake air temperature sensor

1. Check:
- Intake air temperature sensor resistance  
Out of specification → Replace the throttle body.



**Intake air temperature sensor resistance**  
**5.7–6.3 kΩ at 0 °C (32 °F)**

a. Connect the pocket tester ( $\Omega \times 1k$ ) to the throttle body sensor assembly coupler as shown.

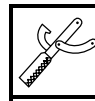

**Pocket tester**  
**90890-03112**  
**Analog pocket tester**  
**YU-03112-C**

- Positive tester probe → brown/white “1”
- Negative tester probe → gray/black “2”

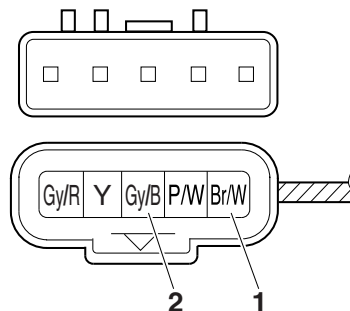

b. Measure the intake air temperature sensor resistance.





## TROUBLESHOOTING

<b>TROUBLESHOOTING</b> .....	9-1
GENERAL INFORMATION .....	9-1
STARTING FAILURES.....	9-1
INCORRECT ENGINE IDLING SPEED .....	9-1
POOR MEDIUM-AND-HIGH-SPEED PERFORMANCE .....	9-2
FAULTY GEAR SHIFTING.....	9-2
SHIFT PEDAL DOES NOT MOVE .....	9-2
JUMPS OUT OF GEAR.....	9-2
FAULTY CLUTCH .....	9-2
OVERHEATING .....	9-2
OVERCOOLING.....	9-3
POOR BRAKING PERFORMANCE.....	9-3
FAULTY FRONT FORK LEGS.....	9-3
UNSTABLE HANDLING .....	9-3
FAULTY LIGHTING OR SIGNALING SYSTEM.....	9-4

EAS28451

**TROUBLESHOOTING**

EAS28460

**GENERAL INFORMATION****TIP**

The following guide for troubleshooting does not cover all the possible causes of trouble. It should be helpful, however, as a guide to basic troubleshooting. Refer to the relative procedure in this manual for checks, adjustments, and replacement of parts.

EAS28470

**STARTING FAILURES****Engine**

1. Cylinder and cylinder head
  - Loose spark plug
  - Loose cylinder head or cylinder
  - Damaged cylinder head gasket
  - Damaged cylinder gasket
  - Worn or damaged cylinder
  - Incorrect valve clearance
  - Improperly sealed valve
  - Incorrect valve-to-valve-seat contact
  - Incorrect valve timing
  - Faulty valve spring
  - Seized valve
2. Piston and piston ring(s)
  - Improperly installed piston ring
  - Damaged, worn or fatigued piston ring
  - Seized piston ring
  - Seized or damaged piston
3. Air filter
  - Improperly installed air filter
  - Clogged air filter element
4. Crankcase and crankshaft
  - Improperly assembled crankcase
  - Seized crankshaft

**Fuel system**

1. Fuel tank
  - Empty fuel tank
  - Clogged fuel tank overflow hose
  - Deteriorated or contaminated fuel
2. Fuel pump
  - Faulty fuel pump
3. Throttle body
  - Deteriorated or contaminated fuel
  - Sucked-in air

**Electrical system**

1. Battery
  - Discharged battery
  - Faulty battery
2. Fuse(s)
  - Blown, damaged or incorrect fuse
  - Improperly installed fuse
3. Spark plug
  - Incorrect spark plug gap
  - Incorrect spark plug heat range
  - Fouled spark plug
  - Worn or damaged electrode
  - Worn or damaged insulator
  - Faulty spark plug cap
4. Ignition coil
  - Cracked or broken ignition coil body
  - Broken or shorted primary or secondary coils
  - Faulty spark plug lead
5. Ignition system
  - Faulty ECU
  - Faulty crankshaft position sensor
  - Broken generator rotor woodruff key
6. Switches and wiring
  - Faulty main switch
  - Faulty engine stop switch
  - Broken or shorted wiring
  - Faulty neutral switch
  - Faulty start switch
  - Faulty sidestand switch
  - Faulty clutch switch
  - Improperly grounded circuit
  - Loose connections
7. Starting system
  - Faulty starter motor
  - Faulty starter relay
  - Faulty starting circuit cut-off relay
  - Faulty starter clutch

EAS28490

**INCORRECT ENGINE IDLING SPEED****Engine**

1. Cylinder and cylinder head
  - Incorrect valve clearance
  - Damaged valve train components
2. Air filter
  - Clogged air filter element

**Fuel system**

1. Throttle body
  - Damaged or loose throttle body joint
  - Improperly adjusted engine idling speed (pilot screw)
  - Improper throttle cable free play

- Flooded throttle body
- Faulty air induction system

### Electrical system

1. Battery
  - Discharged battery
  - Faulty battery
2. Spark plug
  - Incorrect spark plug gap
  - Incorrect spark plug heat range
  - Fouled spark plug
  - Worn or damaged electrode
  - Worn or damaged insulator
  - Faulty spark plug cap
3. Ignition coil
  - Broken or shorted primary or secondary coils
  - Faulty spark plug lead
  - Cracked or broken ignition coil
4. Ignition system
  - Faulty ECU
  - Faulty crankshaft position sensor
  - Broken generator rotor woodruff key

EAS28510

### POOR MEDIUM-AND-HIGH-SPEED PERFORMANCE

Refer to "STARTING FAILURES" on page 9-1.

### Engine

1. Air filter
  - Clogged air filter element

### Fuel system

1. Fuel pump
  - Faulty fuel pump

EAS28530

### FAULTY GEAR SHIFTING

#### Shifting is difficult

Refer to "Clutch drags".

EAS28540

### SHIFT PEDAL DOES NOT MOVE

#### Shift shaft

- Bent shift shaft

#### Shift drum and shift forks

- Foreign object in a shift drum groove
- Seized shift fork
- Bent shift fork guide bar

#### Transmission

- Seized transmission gear
- Foreign object between transmission gears

- Improperly assembled transmission

EAS28550

### JUMPS OUT OF GEAR

#### Shift shaft

- Incorrect shift pedal position
- Improperly returned stopper lever

#### Shift forks

- Worn shift fork

#### Shift drum

- Incorrect axial play
- Worn shift drum groove

#### Transmission

- Worn gear dog

EAS28560

### FAULTY CLUTCH

#### Clutch slips

1. Clutch
  - Improperly assembled clutch
  - Improperly adjusted clutch cable
  - Loose or fatigued clutch spring
  - Worn friction plate
  - Worn clutch plate
2. Engine oil
  - Incorrect oil level
  - Incorrect oil viscosity (low)
  - Deteriorated oil

#### Clutch drags

1. Clutch
  - Unevenly tensioned clutch springs
  - Warped pressure plate
  - Bent clutch plate
  - Swollen friction plate
  - Bent clutch push rod
  - Broken clutch boss
  - Burnt primary driven gear bushing
  - Match marks not aligned
2. Engine oil
  - Incorrect oil level
  - Incorrect oil viscosity (high)
  - Deteriorated oil

EAS28600

### OVERHEATING

#### Engine

1. Clogged coolant passages
  - Cylinder head and piston
  - Heavy carbon buildup

2. Engine oil
  - Incorrect oil level
  - Incorrect oil viscosity
  - Inferior oil quality

**Cooling system**

1. Coolant
  - Low coolant level
2. Radiator
  - Damaged or leaking radiator
  - Faulty radiator cap
  - Bent or damaged radiator fin
3. Water pump
  - Damaged or faulty water pump
  - Thermostat
  - Thermostat stays closed
4. Hose(s) and pipe(s)
  - Damaged hose
  - Improperly connected hose
  - Damaged pipe
  - Improperly connected pipe

**Fuel system**

1. Throttle body
  - Damaged or loose throttle body joint
2. Air filter
  - Clogged air filter element

**Chassis**

1. Brake(s)
  - Dragging brake

**Electrical system**

1. Spark plug
  - Incorrect spark plug gap
  - Incorrect spark plug heat range
2. Ignition system
  - Faulty ECU

EAS28610

**OVERCOOLING****Cooling system**

1. Thermostat
  - Thermostat stays open

EAS28620

**POOR BRAKING PERFORMANCE**

- Worn brake pad
- Worn brake disc
- Air in hydraulic brake system
- Leaking brake fluid
- Faulty brake caliper kit
- Faulty brake caliper seal
- Loose union bolt

- Damaged brake hose
- Oil or grease on the brake disc
- Oil or grease on the brake pad
- Incorrect brake fluid level

EAS28660

**FAULTY FRONT FORK LEGS****Leaking oil**

- Bent, damaged or rusty inner tube
- Cracked or damaged outer tube
- Improperly installed oil seal
- Damaged oil seal lip
- Incorrect oil level (high)
- Loose damper rod bolt
- Damaged damper rod bolt copper washer
- Cracked or damaged cap bolt O-ring

**Malfunction**

- Bent or damaged inner tube
- Bent or damaged outer tube
- Damaged fork spring
- Worn or damaged outer tube bushing
- Bent or damaged damper rod
- Incorrect oil viscosity
- Incorrect oil level

EAS28690

**UNSTABLE HANDLING**

1. Handlebar
  - Bent or improperly installed handlebar
2. Steering head components
  - Improperly installed upper bracket
  - Improperly installed lower bracket (improperly tightened ring nut)
  - Bent steering stem
  - Damaged ball bearing or bearing race
3. Front fork leg(s)
  - Uneven oil levels (both front fork legs)
  - Unevenly tensioned fork spring (both front fork legs)
  - Broken fork spring
  - Bent or damaged inner tube
  - Bent or damaged outer tube
4. Swingarm
  - Worn bushing
  - Bent or damaged swingarm
5. Rear shock absorber assembly
  - Faulty rear shock absorber spring
  - Leaking oil
6. Tire(s)
  - Uneven tire pressures (front and rear)
  - Incorrect tire pressure
  - Uneven tire wear

## 7. Wheel(s)

- Broken or loose spoke
- Damaged wheel bearing
- Bent or loose wheel axle
- Excessive wheel runout

## 8. Frame

- Bent frame
- Damaged steering head pipe
- Improperly installed bearing race

EAS28710

**FAULTY LIGHTING OR SIGNALING SYSTEM****Headlight does not come on**

- Wrong headlight bulb
- Too many electrical accessories
- Hard charging
- Incorrect connection
- Improperly grounded circuit
- Poor contacts (main switch)
- Burnt-out headlight bulb

**Headlight bulb burnt out**

- Wrong headlight bulb
- Faulty battery
- Faulty rectifier/regulator
- Improperly grounded circuit
- Faulty main switch
- Headlight bulb life expired

**Tail/brake light does not come on**

- Wrong tail/brake light bulb
- Too many electrical accessories
- Incorrect connection
- Burnt-out tail/brake light bulb

**Tail/brake light bulb burnt out**

- Wrong tail/brake light bulb
- Faulty battery
- Tail/brake light bulb life expired

**Turn signal does not come on**

- Faulty turn signal switch
- Faulty turn signal relay
- Burnt-out turn signal bulb
- Incorrect connection
- Damaged or faulty wire harness
- Improperly grounded circuit
- Faulty battery
- Blown, damaged or incorrect fuse

**Turn signal blinks slowly**

- Faulty turn signal relay
- Faulty main switch

- Faulty turn signal switch
- Incorrect turn signal bulb

**Turn signal remains lit**

- Faulty turn signal relay
- Burnt-out turn signal bulb

**Turn signal blinks quickly**

- Incorrect turn signal bulb
- Faulty turn signal relay
- Burnt-out turn signal bulb

**Horn does not sound**

- Improperly adjusted horn
- Damaged or faulty horn
- Faulty main switch
- Faulty horn switch
- Faulty battery
- Blown, damaged or incorrect fuse
- Faulty wire harness

# YamahaR125.COM

EAS28740

## WIRING DIAGRAM

### WR125R/WR125X 2009

1. Crankshaft position sensor
2. AC magneto
3. Main switch
4. Rectifier/regulator
5. Main fuse
6. Battery
7. Starter motor
8. Starter relay
9. Starting circuit cut-off relay
10. Diode
11. Neutral switch
12. Right handlebar switch
13. Start switch
14. Engine stop switch
15. Throttle body sensor assembly
16. Intake air pressure sensor
17. Intake air temperature sensor
18. Throttle position sensor
19. Coolant temperature sensor
20. Lean angle sensor
21. Self-diagnosis signal coupler
22. ECU (engine control unit)
23. Ignition coil
24. Spark plug
25. FID (fast idle solenoid)
26. Fuel injector
27. Fuel pump
28. Fuel sender
29. Radiator fan motor relay
30. Radiator fan motor
31. Rear brake light switch
32. Front brake light switch
33. License plate light
34. Tail/brake light
35. Rear right turn signal light
36. Rear left turn signal light
37. Front right turn signal light
38. Front left turn signal light
39. Turn signal relay
40. Horn
41. Headlight relay
42. Left handlebar switch
43. Pass switch
44. Dimmer switch
45. Horn switch
46. Turn signal switch
47. Headlight
48. Auxiliary light
49. Meter assembly
50. Multi-function meter
51. Meter light
52. Coolant temperature warning light
53. High beam indicator light
54. Turn signal indicator light
55. Neutral indicator light
56. Engine trouble warning light

57. Speed sensor
58. Signaling system fuse
59. Headlight fuse
60. Ignition fuse
61. Radiator fan motor fuse
62. Clutch switch
63. Sidestand switch

EAS28750

## COLOR CODE

B	Black
Br	Brown
Ch	Chocolate
Dg	Dark green
G	Green
Gy	Gray
L	Blue
O	Orange
P	Pink
R	Red
Sb	Sky blue
W	White
Y	Yellow
B/W	Black/White
Br/L	Brown/Blue
Br/W	Brown/White
G/B	Green/Black
G/R	Green/Red
G/W	Green/White
G/Y	Green/Yellow
Gy/B	Gray/Black
Gy/R	Gray/Red
L/B	Blue/Black
L/R	Blue/Red
L/W	Blue/White
L/Y	Blue/Yellow
O/B	Orange/Black
O/R	Orange/Red
O/W	Orange/White
P/W	Pink/White
R/B	Red/Black
R/L	Red/Blue
R/W	Red/White
R/Y	Red/Yellow
Sb/W	Sky blue/White
W/B	White/Black
Y/B	Yellow/Black
Y/G	Yellow/Green
Y/L	Yellow/Blue
Y/R	Yellow/Red

YamahaR125.COM

# YamahaR125.COM

MBK Industrie  
Z.I de Rouvroy  
02100 SAINT QUENTIN

Société Anonyme  
au capital de 40 386 000 €  
Téléphone : 33.(0)3.23.51.44.44  
R.C St-Quentin B 329 035 422  
Fax : 33.(0)3.23.51.45.02





YamahaR125.COM

**WR125R/WR125X WIRING DIAGRAM**

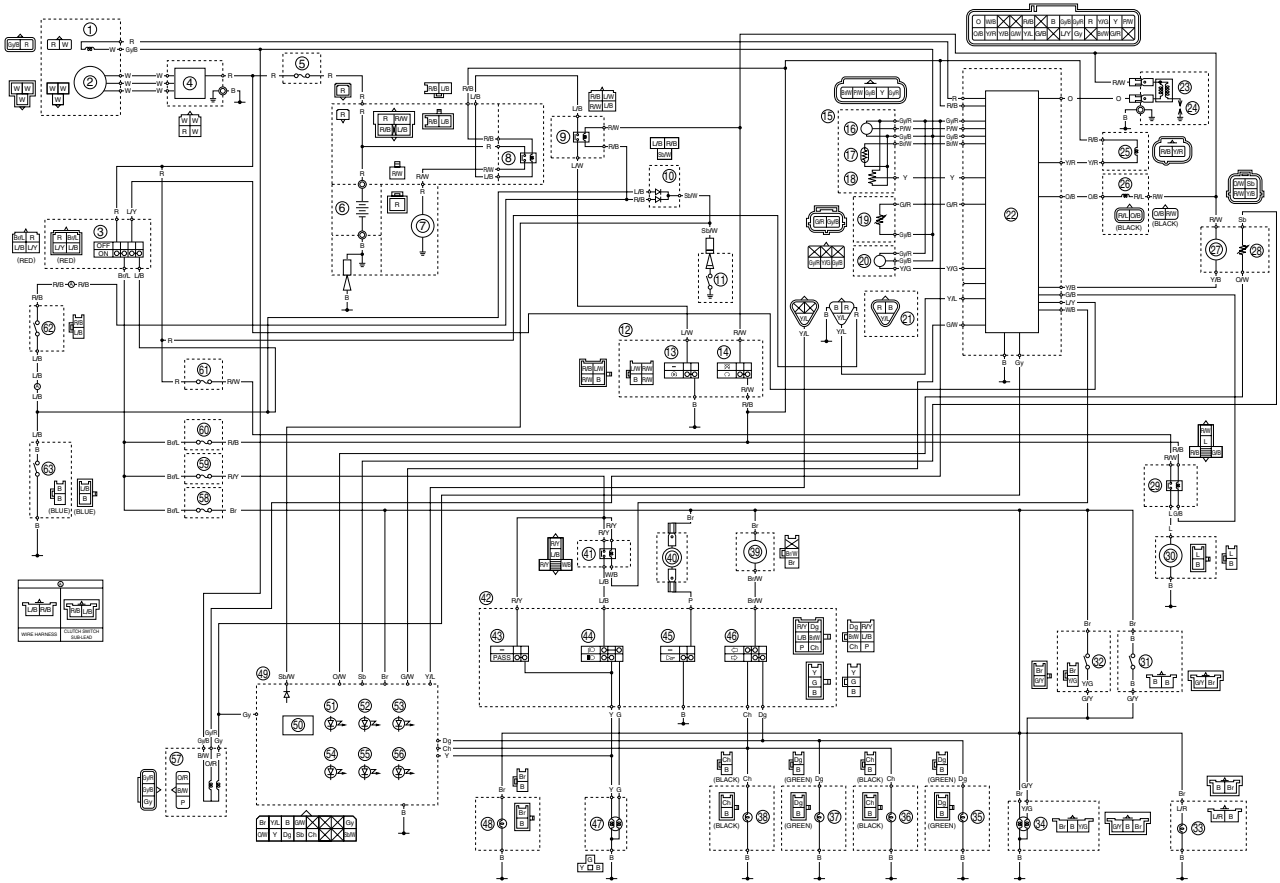

YamahaR125.COM

**WR125R/WR125X WIRING DIAGRAM**

